

AMERICAN THERMOFORM
CORPORATION

1758 Brackett Street
La Verne, California 91750
United States of America

EZ-FORM
OWNER'S MANUAL

Telephone Number: (909) 593-6711
Website: www.americanthermoform.com
Email: sales@americanthermoform.com

TABLE OF CONTENTS

Warranty	3
Section 1, Unpacking/Reshipping Instructions	4-7
A. Unpacking/Preparation For Use Instructions	4-6
B. Reshipping Instructions	6-7
Section 2, Operating Procedures	8-15
A. Initial Electrical Connection	8-9
B. Preparation For Use	10
C. Operating The Brailon Duplicator	10-12
D. Use By The Visually impaired	12
E. Timer/Heater Adjustments	13
F. Machine Shut-Down	13-14
G. Changing Clamp Frames	14-15
Section 3, Periodic Required Maintenance	16-19
Section 4, Operating Difficulties	20-33
A. Electro-Mechanical Operating Sequence	20-21
B. Unit Does Not Operate At All	22-23
C. Oven Does Not Heat	23-24
D. Timer Not Operating	25-27
E. Pump Not Operating	27-29
F. Oven Over-Heating	29-30
G. Oven Enclosure Not Sliding Freely	30
H. Poor (i.e., Fuzzy) Reproduction Copy	31-33
Section 5, Clamp Frame Adjustment	34-38
Section 6, Illustrative Drawing and Parts Lists	39-52
Fig. 1 - Top Assembly Isometric	40-42
Fig. 2 - Oven Enclosure Assembly	43-44
Fig. 3 - Base Cabinet Assembly	45-47
Fig. 4 - Pump Assembly	48-49
Fig. 5 - Clamp Frame Assembly	50-51
Fig. 6 - Wiring Harness Diagram	52

WARRANTY

American Thermoform Corporation's (ATC) EZ Form Machine is warranted against defects in material and/or workmanship for twelve months while in the possession of the original owner. This warranty covers all parts required for the repair; and is made in lieu of other guarantees, expressed or implied, with respect to fitness, merchantability, or quality.

All warranty service must be accomplished by an American Thermoform technician at the La Verne, California plant. The purchaser remains responsible for transportation cost (one way) to American Thermoform in regard to this warranty coverage.

The above warranty does not apply to damage from accident, alteration, misuse, misoperation, or improper packaging. SAVE ORIGINAL CONTAINER AND FOAM INSERTS!

Post Warranty Service

Subsequent to the expiration of this warranty, American Thermoform will supply parts required to maintain the Thermoform in its proper operating condition. Inquiries for this service should be directed to American Thermoform by telephone, to our mailing address, by fax, or to our e-mail address.

The serial/model number can be found on the side nameplate of the Thermoform. Please have available, and use, this serial number when communicating to American Thermoform Corporation about matters related to this unit.

SECTION 1

EZ FORM UNPACKING/RESHIPPIING INSTRUCTIONS

A. UNPACKING/PREPARATION FOR USE INSTRUCTIONS

Step 1. It is suggested the final location for the Thermoform machine be determined before it is unpacked. It is also suggested the area available for its location be at least forty-eight (48) inches deep by sixty (60) inches wide. The Thermoform itself is only twenty inches wide, but the extra width is generally necessary for the lay-out of materials, stacking of finished copies, etc.

(A) Ensure there are no flammable or highly combustible materials within the immediate area of the unit. This requirement is necessary due to the elevated temperatures of the oven enclosure during its operation.

(B) The Thermoform should not be located in an area of extremely restricted circulation, such as a closet; nor should the unit be located in an extremely drafty and/or humid area, such as near an open window exposing it to outside weather conditions.

Step 2. Place the Thermoform on a cleared work area on the floor adjacent to the unit's final location.

Step 3. Remove any additional clamp frame assemblies that may have been ordered with your machine from the top of the foam insert. Remove the white Marinite Heat Shield which is inserted vertically in the special cut-out on the top foam insert. Set the Marinite Heat Shield aside for assembly to the Thermoform at Step 9.

(Health & Safety Note: The Marinite Heat Shield is a calcium-silicate composition material, and is asbestos free.)

Step 4. Remove and retain the top foam insert protecting the Thermoform. Remove any packages of boxed Brailon from the carton that may have been shipped with the machine.

Step 5. With two (2) people, one at the front of the Thermoform and the second at the rear, gently lift the machine from the carton via the rails in the rear and the rails in the front. Set the Thermoform on a table or similar working area, making sure the unit is clear of all obstacles.

(The Thermoform machine should never be lifted via the oven handle. Transporting of the machine via the oven handle at any time can void the warranty in terms of structural damage.)

Step 6. Replace the top foam insert into the shipping carton and store. Note: This carton is designed as a reusable shipping container, and should be retained for use in returning the Thermoform machine for repair work at a later time.

Step 7. Remove the tywrap which temporarily secures the latch handle to the front of the unit. Move the oven enclosure to its rear most position. Locate, remove and retain the hex clamp frame adjusting wrench taped to the front of the clamp frame assembly installed on the unit. Locate and remove the two pieces of tape securing the clamp frame retaining pins to the baseplate lugs at the rear of the baseplate. The clamp frame retaining pins are to remain inserted in place.

Step 8. Locate the braided, base-to-oven flexible conduit on the rear, right hand side of the Thermoform. Using your fingers, align and hand tighten the two (2) knurled nuts to the fittings on both the oven enclosure and the base cabinet. Hand-tighten only to the degree necessary to prevent the conduit from turning as the oven enclosure is moved back and forth across the unit.

Step 9. Remove the four (4) wing-nuts and eight (8) washers from the four screws protruding down from beneath the two rear base cabinet rails. Install the marinite heat shield below the rails as follows:

Placing four of the washers over the four holes drilled in the Marinite, match and slide the Marinite up and through the four screws. Using the other four washers and the four wing nuts on the bottom side, hand-tighten the Marinite into place. (Note: Refer to Section 6, Figure 1, item 10 for pictorial aid as required.)

Step 10. Remove the tywrap from the electrical power cord - - DO NOT PLUG THE UNIT INTO ANY ELECTRICAL POWER SOURCE AT THIS TIME.

This Completes The Unpacking/Preparation For Use Instructions. Now refer to section II, Operating Instructions, for additional information.

B. RESHIPPING INSTRUCTIONS

(Notes: These instructions are to be followed when it is necessary to repack the unit for return to ATC for repair work, or for shipment to another location or destination. At times it may not be necessary to return the entire machine for repair of a specific item. Contact authorized service personnel for more details in this area.)

Step 1. Retrieve the reusable shipping carton and foam inserts originally received with the Thermoform. If one is unable to locate the carton and inserts, a new set can be ordered from ATC.

Step 2. Unplug the Thermoform from its electrical power source.

Step 3. Remove the Marinite Heat Shield from the unit, storing it in a safe place while separated from the machine. Return the washers and wing nuts to the four screws on the bottom of the rear rails.

Step 4. Loosen the two (2) knurled nuts securing the flexible oven-to-base conduit to the two enclosures. Ensure the white wires inside the conduit are visible, thereby allowing the conduit to be bent freely up against the unit as it is placed into the carton.

Step 5. Using masking tape, tape the two (2) clamp frame retaining pins in position. Ensure the clamp frame latch handle is closed, and tape over the handle so as to secure it to the unit. Wind and tape the electrical power cord to keep it out of the way during repackaging.

Step 6. With the shipping carton open and using two people, insert the Thermoform into the recess in the bottom of the foam insert. This is best done by lifting on the rails in the rear and rails in the front.

Step 7. Ensure the electrical power cord rests freely within the carton and is not pinched. Ensure the same is also true for the flexible oven-to-base conduit.

Step 8. Confirming the unit rests firmly inside the bottom insert recess, move the oven enclosure to an approximate midpoint inside the carton. Position the top foam insert so the two clamp frame inserts or cut-outs are up, and the square viewing hole is over the right rear corner of the oven. Now placing the top foam insert over the carton, position the oven enclosure through the square cut-out so it is secured within the recess in the bottom side of the top insert. Press down firmly on the top insert until it is flush with the top of the shipping carton.

Step 9. If there is one or more alternate sized clamp frames for the Thermoform being returned, be sure to include them in the special cut-outs on top of the upper foam insert. Enclose any correspondence desired on top of the foam insert. DO NOT return the owner's manual nor the Marinite Heat Shield with the unit.

Step 10. Using reinforced tape, seal the ends and top seam of the shipping carton. Affix the proper shipping and return address labels.

Means of Shipment

Shipments to and from American Thermoform Corporation from within the continental United States can best be made by United Parcel Service (UPS).

If a scale is not available to weigh the returning carton, one can use an estimate of 84 pounds for the EZ Form with one frame. (Add an additional 5 pounds for each spare clamp frame enclosed.)

SECTION 2

OPERATING INSTRUCTIONS

A. INITIAL ELECTRICAL CONNECTION

1. Ensure the Marinite Heat Shield is properly attached to the unit per the Preparation for Use Instructions, step 9, section 1. If there is any question as to the installation, refer to section 6, figure 1, item 10. Also ensure the unit is not in the proximity of any flammable or highly combustible materials.

2. The “RDA” series of standard Thermoform machines are designed to operate on one of the two following single phase, electrical systems:

- 110 (+/-10%) volts, 50 cycles (or) 115v/60c

- 220 (+/-10%) volts, 50 cycles (or) 230v/60c

Operation of the unit on an electrical system other than that for which it was manufactured voids the warranty.

3. A safety feature of the Thermoform machines is a thermally activated, circuit breaker. This circuit breaker and the associated single pole on-off switch are wired on the “hot” or power leg of the applicable electrical power system.

For United States of America, or domestic, 115v electrical power systems, maximum effectiveness of these features can be obtained by ensuring the power cord is plugged into a standard, grounded wall receptacle. Doing so will provide the proper “polarization”. If a grounded, or 3 hole, wall receptacle is not available, the polarized, 2 prong grounding adapter, provided with the unit, should be used.

For non-domestic 115v systems or 220v* systems, special modification adapters may be necessary. These adapters are to be provided by the using customer. As illustrated below, the “hot” leg should be connected to the power side of the 115/208/220v or the 220/380/440v circuit.

*220v CE Marked machines have electrical cords installed for designated countries.

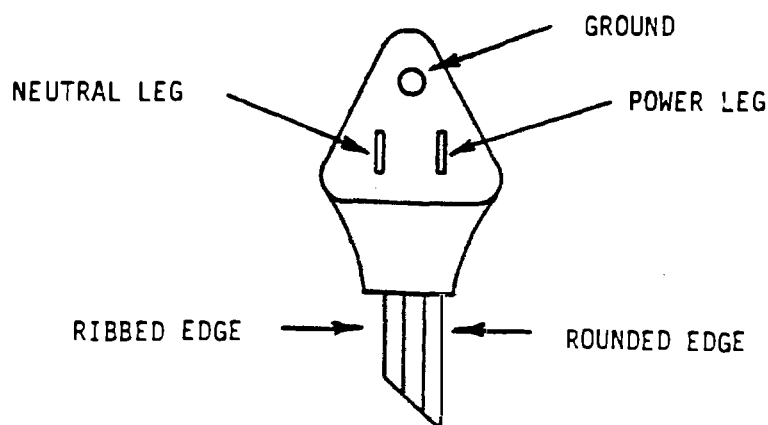

4. Observing the precautions noted in paragraphs 2 and 3 above, plug the power cord into the proper electrical receptacle. Each Thermoform, especially the 115v unit which is drawing approximately 13 amps of current, should be connected directly into its own circuited wall outlet. The use of extension cords is strongly discouraged. If absolutely necessary, however, a minimum of a 14-3 AWG extension cord should be used if the total length is under twelve feet, or a 12-3 AWG size cord if the length exceeds twelve feet.

***** Special Notes *****

Once the unit operates properly for the first time with the user, it is not necessary to repeat steps 1 through 4 each time the machine is used. Subsequent use of the Thermoform can be started with section B of these instructions.

B. PREPARATION FOR USE

1. Verify that the Marinite Heat Shield is properly in place. If in doubt, refer to section 6, figure 1, item 10.
2. Slide the oven enclosure to the extreme rear of the unit.
3. Turn the on/off switch on the left hand side of the unit "up" to the "on" position. The green indicator light should be on, confirming there is main "POWER" to the unit.
4. Locating the large black knob to the extreme right of the unit marked "HEAT", turn it to the "HI" position. This knob actuates the heater control switch, which controls the relative temperature of the oven unit. The oven is now heating. It will take approximately fifteen minutes for the unit to reach operating temperature.

The oven enclosure should always be in its rear most position except when running a copy. Leaving the oven enclosure over the clamp frame assembly while hot will warp the aluminum clamp frame, and result in probable vacuum leaks. Such operation would void the applicable warranty coverage.

(Safety Note: The coils within the oven unit are in excess of 800 degrees Fahrenheit and the lower exterior portion of the oven enclosure in excess of 250 degrees at operating temperature. Accordingly, it is essential that personnel within proximity of the unit exercise caution, and that no flammable materials be stored within the immediate area.)

C. OPERATING YOUR EZ FORM MACHINE

1. After the appropriate warm-up period, unlock the clamp frame latch handle and swing the frame all the way open. The clamp frame should be resting against the oven enclosure in its rear most position.

2. Locating the large black knob just to the right of the latch handle marked "TIME", set the timer for 5.0 seconds .
3. Place the braille page or master copy to be duplicated on the screen manifold (i.e., the metal screen with the small holes and rubber edging). The braille points or reading side should be up.

***** Special Note *****

The master page must be of a permeable material. One can not make a Brailon copy of a master where air can not be drawn through it. For example, one can not use a Brailon copy or similar plastic sheet as the master for subsequent copies.

4. Position the proper size sheet of Brailon over the top of the braille page (i.e. the master). Ensure the Brailon is placed all the way into the upper left hand corner of the screen manifold so it touches the two raised edges. (Note: The master copy can be equal to or smaller than the Brailon sheet, but the Brailon must be equal to or larger than the size of the clamp frame/ manifold being utilized.)
5. Lower the clamp frame assembly down over the master and the Brailon sheet, and latch the handle. (Note: The latch handle should be secured with only the minimal force necessary. Applying extreme force each time will prematurely wear out the yoke bushing or possibly warp the clamp frame.)

The Brailon sheet should be secured under all sides of the rubber seal on the inside bottom edge of the clamp frame. Should the master document be visible, the proper size Brailon sheet has not been used and the final copy will be unsatisfactory.

6. Briskly pull the oven enclosure all the way forward until it gently strikes the oven stops at the front part of the unit. Continue to hold the oven enclosure in this forward most position. This forward most position of the oven will actuate the timer by depressing the microswitch in the front, right hand corner. When this occurs, the second orange indicator light, marked "TIMER", will come on, confirming electrical power to the timer.

7. When the timer completes its cycle, the vacuum pump within the Thermoform will be actuated. One will know when this happens by the sound of the pump in operation. In addition, the third, blue indicator light, marked "PUMP", will come on, confirming electrical power to the pump. Immediately push the oven enclosure to its rear most position!
8. Push the red knobbed switch, marked "PUMP RESET". This action will electrically reset the timer and pump for the next copy cycle to be run. At this time, the two indicator lights, marked "TIMER" and "PUMP", will also go out .
9. Unlatch the clamp frame handle and swing it up against the oven enclosure. Now remove the finished Brailon copy.
10. The Thermoform machine is now ready for the next copy which can be made by repeating steps C-1 through C-9.

D. USE BY THE VISUALLY IMPAIRED

To assist the visually impaired in the use of the Thermoform machine, two raised indicators have been added to the timer control knob and the heater control knob. Operation of the other control features, such as the "on/off" switch and the "pump reset" switch would be by spatial relationship or touch.

On the front faceplate under the words "TIME" and "HEAT", raised rivets are installed at the "twelve o'clock" position just above each of the two control knobs.

On the timer control knob, a second rivet is added on the skirt flange at the 4.5 second location. This setting is a fairly typical one when making repeated copies, and provides the visually impaired operator with a second reference point by which to adjust the time for the best copies possible.

On the heater control knob, the second rivet is added on the skirt flange at the 5.5 setting. Again, this setting is a typical one when making repeated copies, and provides the visually impaired operator with a second reference point by which to adjust the temperature for the best possible copies.

E. TIMER/HEATER ADJUSTMENTS

1. Due to a wide variety of environmental factors, no set rule can be applied to the timer/heater adjustments other than to “use the minimum settings which give the best results”. Experience has shown, however, that the heater control switch should be used as the coarse adjustment, and the timer setting as the fine adjustment.
2. If one is duplicating between five to fifteen copies, the heater control knob should be typically set between 5 and 6, and the timer should remain at approximately 5 seconds.
3. After fifteen copies, as the clamp frame tends to retain the built-up heat, the heater control setting should be typically reduced to 5, and the timer should be reduced to approximately 4 seconds.
4. When using Heavy Brailon, the heater control setting should be typically between 5 and 6, and the timer should be increased to 7 or 8 seconds.

*** Special Note ***

The oven heating element is wired so that the outer coil is always on whenever the temperature control switch is in any position except “OFF”. The inner coil is wired so that it is regulated by the thermostat within the heater control switch. Accordingly, the outer coil should always have a red glow, while the inner coil will cycle on and off. One should not be concerned if at times the inner coil does not appear to be on. However, the inner coil should not be on constantly unless the heater control switch is in the “HI” position, such as during machine warm-up.

F. MACHINE SHUT-DOWN

1. There are no special precautions or requirements associated with shutting off the unit except that (a) the oven enclosure should not be left over the area of the clamp frame while cooling, and (b) some means should be utilized to cover the unit while not in use. The purpose in providing covering protection is to prevent the accumulation of dust and debris under the screen manifold, which will then

be drawn into the vacuum pump on its first copy. The easiest way to accomplish this protection is to insert a sheet of Brailon within the clamp frame assembly when the unit is not in use.

When no additional copies are desired, the heater control switch should be turned to the "OFF" position and the main electrical power switch turned to the off position.

G. CHANGING CLAMP FRAMES

1. Clamp frame assemblies and their respective screen manifolds are custom fitted to each unit, and are not normally interchangeable across Thermoforms. When more than one size clamp frame is ordered with a particular unit, each frame is custom fitted and so serialized. The serial number of the unit to which a given clamp frame was fit is indicated by the stamped number just above the latch handle.

When a replacement clamp frame is ordered at a later time, it is fit to within a tolerance range at the factory and stamped with the word "SPARE". In most cases, this spare/replacement clamp frame will require adjustment per the instructions in Section 5 before it will produce satisfactory copies.

2. With the alternate size clamp frame and screen manifold at hand for a given Thermoform, remove the two clamp frame retaining pins at the rear lugs of the baseplate.

3. The most important point to remember in the changing of a clamp frame assembly is that the clamp frame should be slid in and out of the baseplate lugs while in a vertical position. Also, should the installed clamp frame be hot due to recent usage, allow it to cool to the point where it can be handled without the possibility of being burned.

4. Unlatch the currently installed clamp frame, gently maintaining a constant pressure or pull towards the front. Now, placing your free hand around the rear axle of the clamp frame, rotate the clamp frame up and back ninety degrees into a vertical position using the latch handle.

5. With the clamp frame in its vertical position, slide the axle backward towards the oven enclosure until it clears the notches in the lugs. Now lift up and remove the clamp frame assembly.
6. Remove the installed screen manifold by lifting up on the rear edge until it clears the two locating pins.
7. Position the new size screen manifold over the baseplate with the two locating holes to the rear, and the two raised rubber edges to the left and rear respectively. Gently slide the manifold down over the two locating pins.
8. While holding the new sized clamp frame assembly vertically by the axle in one hand and by the latch handle with the other hand, position the axle just behind the two notches in the baseplate lugs. Now slide the clamp frame axle into the notches. Then while maintaining a slight forward pressure, or pull on the latch handle, rotate the clamp frame assembly down into position.
9. Reinsert the two clamp frame retaining pins removed in step 2. Ensure the pins are resting within the grooves across the rear top portion of each baseplate lug.

The new size clamp frame assembly is now ready to use.

**** Special Notes ****

(A) Should the clamp frame jam by being cocked during its removal, it can be gently tapped to reposition it for proper removal. However, “hammering it loose” can gall the frame and/or lugs, and even possibly bend it. Should the lugs or frame become galled, any resulting burrs should be filed off prior to reinstallation.

(B) The oversized metric or European baseplate has a double set of notches in each lug. The 27 x 34 centimeter clamp frame fits in the rear most notches. The 21 x 29.7 centimeter or DIN A4 clamp frame fits in the forward most notches. The 27 x 34cm manifold would fit over the two locating pin holes to the further rear of the baseplate. The locating pin hole for the DIN A4 manifold is the second set of holes closer to the front of the rear of the baseplate.

SECTION 3

PERIODIC REQUIRED MAINTENANCE

The following maintenance operations should be performed at the general time periods indicated. No other type of preventative or other service maintenance is required unless specific problems develop. Ensure the electrical power to the unit is off during each of these maintenance procedures unless specified otherwise.

A. MONTHLY

1. Clamp Frame/Screen Manifold/Baseplate Cleaning:

Approximately once a month, the rubber seal on the bottom of the clamp frame and the rubber on both sides of the screen manifold should be cleaned with a cloth rag dampened with lacquer thinner. (Note: Lacquer thinner can be obtained at most paint or hardware stores. Lacquer thinner is also a combustible solvent, and should not be stored in immediate proximity to the unit.)

During this cleaning, the aluminum baseplate should also be wiped down with lacquer thinner, followed by a water based cleaner such as Windex, etc. Do not use any product which can result in a wax build-up.

To avoid possible damage to the plastic control knobs by the lacquer thinner, it is suggested the clamp frame assembly and the screen manifold be removed completely from the unit. Exercise caution during this maintenance task to ensure the screen manifold is not bent during its removal, cleaning, or reinstallation. Should one also have more than one Thermoform machine, ensure the proper serialization is maintained on the clamp frame assemblies and the respective screen manifolds.

The purpose of this cleaning is to prevent the build up of debris or other materials that may adversely effect vacuum performance.

B. BI-ANNUALLY

1. Lubrication of the Oven/Base Cabinet Rails.

As dirt and metallic residue build up in the rail assemblies, or if the rails appear to be totally dry, they should be cleaned and relubricated at least once every two years. Refer to section 6, figure 1 as an aid to identify the parts to be disassembled and lubricated on the unit.

To accomplish this maintenance task, it is necessary to (a) remove the clamp frame assembly and screen manifold from the baseplate, (b) remove the oven enclosure from the base enclosure rail assemblies, and (c) remove the ball bearings and races from within the base cabinet rails.

Having removed the clamp frame assembly and the screen manifold, loosen the two knurled nuts which hold the oven to base cabinet flex-conduit in place. It is not necessary to disconnect this conduit; rather there is enough slack to permit the oven to slide clear of the base cabinet rails. Now remove the four screws and nuts holding the two oven stops in place.

Once the oven stops are removed, slide the oven enclosure all the way forward until it clears the two rails. One should exercise care that the ball bearings do not fall out onto the floor and become lost. Once clear, lay the oven unit to the right of the base cabinet with the oven conduit still attached. Now locate and remove the two races and the six ball bearings in each race. Again, use extreme care that the three ball bearings on the bottom half of each race do not fall out and become lost as each race is removed.

With all required parts disassembled, clean (a) the two oven rails riveted to the enclosure, (b) the insides of the two rails riveted to the base cabinet, (c) the two races, and (d) the twelve ball bearings. Lacquer thinner or a similar type solvent is recommended.

Using Dow-Corning Silicone Compound Number 7, obtainable from American Thermoform (ATC) as part number P150094, apply a light coat of grease to the outside of the oven rails and to the inside of the base cabinet rails. Now apply a dab of silicone grease into the six ball bearing holes in each race. Insert the first upper and lower set of ball bearings into their position in the race, and slide the

race into the rail up to the position of the second set of holes. Now insert the second set of upper and lower ball bearings, and continue this routine until both races are fully inserted into the base cabinet rails.

(Note: Dow-Coming Silicone Compound Number 7 is a high temperature releasing agent, and is the **only** recommended product to be used for this application. The use of a conventional oil base grease will prove unsatisfactory due to the fact it will run under the elevated temperatures involved, and will soil both the braille master and the Brailon copies.)

Now reinstall the oven enclosure by sliding the inner rails into the outer rails, paying attention to the fact that the inner rails fit between the ball bearings located in each race. It is usually necessary to slide the oven unit to the extreme rear of the rail assemblies before both races and ball bearings properly position themselves. Once one is assured the oven and rail assemblies are operating properly, return the two oven stops (and inner oven stops as required) to their position and secure. Now retighten the two knurled nuts on the oven to base cabinet flex-conduit.

This completes the required lubrication of the oven and base cabinet rail assemblies.

C. AS REQUIRED

1. Vacuum Pump Overhaul/Internal Cleaning:

For the Thermoform machine to provide the proper copies, the vacuum pump must provide a minimum of twenty-two (22.0) inches of vacuum on a mercury gauge. A new or reconditioned pump will typically test at 23.5" to 25.0" of Hg.

In a relatively clean environment, the vacuum pump will typically provide a minimum of four to five years of reliable service before requiring an internal cleaning/overhaul. However, in an extremely dusty, sandy, or humid salt-water environment, the pump will start to collect debris in the reed or port assemblies, and may even start to corrode in as little as two years. As a consequence, the vacuum will start to fall and the copies will become marginal or unsatisfactory.

To correct this problem, (a) the internal chambers of the pump head need to be cleaned, and (b) a new rubber diaphragm (part number P150945) and pump overhaul kit needs to be installed. The pump overhaul kit consists of two new reed assemblies, three new sponge filters, and a new rubber head gasket. This kit can be obtained from ATC as part number P150982. ATC also has a relatively inexpensive vacuum test gauge available by which one can periodically monitor the performance of the pump. The part number for this test gauge is P150371.

The instruction sheet which accompanies this overhaul kit is self-explanatory, so this maintenance procedure will not go into a lot of detail. However, this procedure does address how to gain access to the vacuum pump, and the general nature of the task for reference purposes when an overhaul/cleaning is required.

To begin, roll the unit over on its right side. Remove the bottom base cover, and disconnect the rubber vacuum hose from the vacuum pump at the swivel fitting. Do not unscrew the rubber vacuum hose where it enters the aluminum baseplate. Now turn the unit over to its proper upright position.

Remove the four screws that hold the base cabinet to the pump frame assembly, two from the left front and center position, and two from the right front and center position. Refer to section 6, figure 1 for assistance. Loosen, but do not remove, the two rear screws. Slide a 4" x 4" piece of wood or similar sized piece of material under the back side of the unit. The objective is to raise and support the rear of the unit approximately four inches off the table or work surface. Now while pulling down on the pump frame assembly from the front, rotate the oven and base cabinet up and back. This action will open the unit like a "clam shell". The main weight of the Thermoform will be resting on the 4" x 4", or similar support material, and on the ends of the rails in the rear, with the pump exposed to the front.

Upon completion of the overhaul, the unit should be closed up and the vacuum hose reassembled to the pump. The pump can then be tested for satisfactory performance prior to reinstallation of all fasteners.

SECTION 4

TECHNICAL MANUAL

This technical manual provides a general outline of the electro-mechanical operating sequence of the Thermoform machine, followed by a Problem/Possible Causes/Corrective Action listing. This manual can act as a guide in categorizing a problem a user may have with the unit, the possible causes, and the corrective actions required.

Should the user be experiencing a difficulty which is not exactly described in this Technical Manual, or should the corrective action not resolve the difficulty, then please feel free to call, e-mail or write ATC directly. Should the user decide to write, it would be very beneficial if a sample of the poor copy or difficulty is submitted with the user's correspondence.

A. ELECTRO-MECHANICAL OPERATING SEQUENCE

This brief outline is intended for technical or maintenance personnel who may be preparing to service the Thermoform machine. This outline, in conjunction with the wiring schematic and the wiring harness diagram in section 6, figure 6, can aid in understanding the electro-mechanical operation of the unit.

1. Electrical power to the Thermoform is controlled through the on-off switch. Activation of this primary circuitry is indicated by the green "Power" indicator light.
2. With the electric power on, the heater control switch regulates power to the 1300 watt, dual heating element. Power to the heater control switch and the heating element is in no way related to the circuitry of the timer or vacuum pump.

The heating element is wired so the outer coil, of approximately 600 watts, is on in any heater control switch position other than "Off". The inner element, of approximately 700 watts, is wired to be (a) on in the "Hi" position, and (b) thermostatically controlled in any of the positions between "Hi" and "Lo".

The “black” and the “white” oven wires provide the neutral power leads to the outer and the inner heating element coils respectively. The “green” oven wire is the hot power lead, and is common to the secondary side of the inner and outer heating coils via the buss bar.

3. With the oven enclosure up to temperature after approximately fifteen minutes, the master and the Brailon copying material are inserted between the clamp frame and screen manifold.
4. As the oven enclosure is brought all the way forward over the clamp frame assembly, a small extension on the forward right-hand corner of the oven cabinet closes the normally open snap-action switch. Closing this snap-action switch provides electrical power to the double pole, double throw, on-delay relay timer via timer block positions 2 and 10. Activation of this circuit is indicated by the orange, or second “Timer” indicator light.
5. The time delay factor of the relay timer is controlled by the resistance value in the remote potentiometer via timer block positions 5 and 7. When the relay times out, pole number 1, normally open as timer block positions 9 and 11, close, maintaining power to the relay. Pole number 2, also normally open as timer block positions 1 and 3, close, providing electrical power to the vacuum pump. Activation of this contact set 2 circuit is indicated by the blue, or third “Pump” indicator light.
6. At this time the oven enclosure is pushed back to its normal position away from the clamp frame assembly. The snap-action switch opens, but power remains to the timer relay and pump via orange jumper from timer block terminal number 11 to terminal number 10. After the clamp frame assembly is opened and the Brailon has cooled to below its thermoforming temperature range, the normally closed, momentary “Pump Reset” switch is pushed to open the circuit to the relay timer. When electrical power is lost to the relay timer, the timer “resets” to its normally open contact or pole positions. This causes the timer and the vacuum pump to cease operation, which is confirmed by the “Timer” and the “Pump” indicator lights going out.
7. The above process is then repeated as often as necessary to obtain the number of copies desired. Upon completion of the copying task, power is turned off to the unit via the “on-off” switch.

B. UNIT DOES NOT OPERATE AT ALL WHEN TURNED ON

Causes:

- (1) No exterior power source to the unit
- (2) Open circuit breaker in the unit
- (3) "On" indicator light burned out
- (4) Defective on/off switch
- (5) Broken or loose wire in the wire harness
- (6) Broken wire/plug on the lead-in power cord

Action:

- (1) Using a test probe, voltmeter, or other electrical device, confirm power is available to the wall receptacle. Correct as required.
- (2) Locate the circuit breaker on the front, right hand cabinet panel. Ensure the white extension piece is pushed in (i.e., flush with the face of the cabinet). If the circuit breaker continues to open once reset, there is an electrical short circuit. This short must be located and corrected prior to use. Note: The circuit breaker will not operate, even if one attempts to hold the reset button in by force.
- (3) If one turned the unit on and the "on" indicator light did not come on, this does not mean there is no electrical power to the unit. Set the timer knob to 1 or 2, and depress the microswitch roller in the front right hand corner under the rail/oven stop. If the vacuum pump comes on, there is power. Replace the "Power" indicator light.
- (4) Roll the unit over on its right side and remove the bottom cover plate. With the unit still turned on, use a test probe, or voltmeter, to determine if power is present at the two quick disconnect lugs of the on/off switch. If power is present and turning the switch off and on does not activate the unit, the switch is defective. Replace the on/off switch. If power is not present, the problem is in the lead-in cord or wire harness.

(5) With the bottom cover plate removed from step 4 above, remove the power cord from the wall receptacle. Inspect the wire harness, and its quick disconnect terminals, to locate any broken or loose connections. Check the wire bundle in the back right hand corner behind the vacuum pump to ensure all leads are tight and covered with a crimped wire joint. Repair or replace as required.

(6) Inspect the lead-in power cord for any broken areas. With extensive use, and especially if the plug is bent back and forth as it is plugged in, the internal wires immediately adjacent to the plug can break. Cut off the existing three prong plug and replace with an equivalent three prong plus. Use extreme care to ensure the ground wire is connected to the proper prong. (Refer to section 6, figure 6).

C. OVEN DOES NOT HEAT (One or Both Coils)

Causes:

- (1) Unit not plugged in (or) power not on
- (2) Heater control switch not on
- (3) Broken lead in the base to oven wire set
- (4) Broken wire in the heating coil element
- (5) Loose connection inside the oven assembly
- (6) Heater control switch is defective

Action:

- (1) Ensure the unit is plugged in and the main electrical power switch is in the up or "on" position.
- (2) Ensure the heater control switch is in a position other than "off". If the heater control knob rotates on the control switch stem, tighten via the two allen wrench set screws ensuring the "off" position indicator is opposite the flat on the heater control switch stem.
- (3) Ensure the unit is unplugged from its power source and loosen the two knurled nuts securing the base to oven flex-conduit. Pull back on the conduit to expose approximately one and a half (1.5) inches of wire. Inspect for broken

leads across any of the three wires. If there is a broken lead, it is most likely to occur immediately adjacent to the oven enclosure fitting. **Replace - using only a factory supplied high temperature wire set. Do not attempt to repair any broken wires in this critical area!**

(4) Remove the marinite heat shield and roll the unit over on its right side. Using a wooden pencil or similar type soft instrument, gently tap both the inner and outer oven coils to locate any broken spots. If a broken coil exists, replace heating element.

(5) With the unit on its right side and unplugged, remove the bottom cover plate. Disconnect the white and the green and white wires at the bottom of the heater control switch. Using an ohm meter, measure the resistance across the two wires. It should measure approximately 15 ohms on the 115v unit and 64 ohms on the 220v unit. Now measure the resistance between the black wire at the top of the heater control switch and the green wire. It should measure approximately 21 ohms on the 115v unit and 77 ohms on the 220v unit. If either test indicates an open circuit, it must be located and repaired as required. Use extreme caution to ensure the green wire is reconnected to the "H1" terminal on the heater control switch, and the white wire to the "H2" terminal.

(6) Disconnect all four wires from the back of the heater control switch. Using a piece of electrical tape, secure the double brown and the green wires together so the quick disconnect terminals are making good contact. Using a second piece of tape, now secure the double black and the white wires together. With the Thermoform still on its side, plug the unit into its normal power source. Within a few minutes, both coils of the heating element should be heating. This test confirms the heater control switch was defective, and it should be replaced. When completing this repair installation, ensure the four individual wires are connected to their proper position at the back of the heater control switch. **Caution - Do Not Attempt to operate the unit in this by-passed heater control switch condition. The possibility of an electrical short-circuit and permanent damage to the unit is extremely high.**

D. TIMER NOT OPERATING ("Timer" Indicator Light May Or May Not Be On)

Causes:

- (1) Timer set too high
- (2) Oven enclosure not held forward sufficiently
- (3) Microswitch/timer circuit not being closed
- (4) Low voltage
- (5) Indicator light burned out
- (6) Pump reset switch defective
- (7) Microswitch defective
- (8) Timer potentiometer defective
- (9) Timer defective

Actions:

- (1) Ensure the timer control knob is set for five (5) seconds or less. It is also important that the heater be set at no higher than 5 or 6 if the unit has been on for some period of time.
- (2) Per step 6, paragraph C, section 2, the oven enclosure must be held in its forward most position during the "timing" cycle. This position ensures the oven extension piece is closing the timer circuit via the microswitch in the front, right-hand corner. If the oven is not being held forward sufficiently, one will usually see the "Timer" indicator light come on for a second or two, and then go out when the oven rolls backwards/opens the circuit. The timer will only operate properly if there is a continuous closed electrical circuit for the period of time indicated by the timer control knob setting.
- (3) Even though the oven is being held forward sufficiently, there is the possibility the circuit is not being closed. To test for this condition, move the oven enclosure to its rear most position. With the main power on, depress the microswitch roller knob with your finger. This knob is located in the front right hand corner, through a hole just under the rail assembly. If the timer light comes on when you press the microswitch with your finger, but not when the oven is brought forward, the microswitch arm is bent. To correct, insert a small screwdriver just under the microswitch knob and gently bend it up. Retest with

the oven enclosure as required. This condition can also be verified by listening to the “click” the microswitch makes when the oven enclosure is rolled over the top of the switch roller knob. The lack of the “click” means the circuit has not been closed and/or opened properly.

(4) Both the timer and vacuum pump can fail to operate, or will operate erratically, if there is too low a voltage to the unit. A borderline low voltage situation to the timer is best identified by a “fluttering” sound from the main relay coil in the timer housing. This “fluttering” will also be reflected in the “Timer” indicator light. If the voltage is abnormally low, no fluttering will be observed, the timer just won't operate.

Check step 2, paragraph A, section 2, Initial Electrical Connection, of the Owner's Manual to verify the minimum voltage requirements of this unit. The voltage available to the unit can be checked via a voltmeter, or similar testing instrument.

(5) If the “Timer” light does not come on when the oven enclosure is pulled forward, this may not mean the timer is not working. Using the test similar to that in step 3 above, set the timer control knob for 0 to 1 seconds and then press the microswitch roller knob in the front, right-hand corner for a period of several seconds. If the vacuum pump starts, but the “Timer” light has not come on, this means the light is defective and should be replaced.

(6) The pump reset switch is a momentary, normally closed type of switch. If this switch is defective, the timer will not be activated by the closing of the microswitch. To test this switch, roll the unit over on its right side and remove the bottom cover panel. Using an ohmmeter, test to confirm a closed circuit. The circuit should be broken or open any time the “Pump Reset” switch is being pushed in. If defective, replace.

(7) Roll the unit over on its right side and remove the bottom panel. After confirming the “Pump Reset” switch is operating properly as noted in step 6 above, loosen the two screws on the bottom of the microswitch and remove the two wires. Using a piece of electrical tape, tape the brown and orange wires together so the two terminal forks are in solid contact with each other. Now set the timer control knob for 1 to 2 seconds and plug the unit into its proper power source. If the microswitch was defective, the timer will complete its cycle and

the pump will start within the time period set on the timer control knob. Replace as required, ensuring one wire goes to the “common” screw and the second wire to the “normally open” screw.

(8) The “RDA” series timer is actually made up of two components, the remote timer control switch (i.e., a potentiometer), and the main relay housing. To test for a defective potentiometer, roll the unit over on its right side and remove the bottom cover panel. Ensuring the unit is unplugged from its power source, remove the main timer relay housing from its block. Disconnect the two gray wires going to terminal block leads 5 and 7. Using an ohmmeter, measure the resistance at a series of timer control settings. The proper value should be 100,000 ohms times the value of the setting, plus or minus 10% (100,000 ohms at 1 second, 600,000 ohms at six seconds, etc). The potentiometer should be replaced if the above values are not obtained, or if there are severe jumps or voids in the linear continuity of the potentiometer. Note: In replacing the main relay housing into the timer block, there is a locating keyway in order to register the proper “terminal to contact” positions. **Do not attempt to force the relay into place without aligning the proper keyway position.**

(9) Ensuring the remote potentiometer leads and main timer relay are reinstalled from step 8 above and with the unit still rolled over on its right side, plug the unit into its proper power source. Set the timer control knob for 1 to 2 seconds, and listen for a faint “click” from within the main relay housing as the microswitch roller knob is depressed as outlined in step 3 above. If one does not hear a “click”, the main relay coil is defective and the timer should be replaced.

E. PUMP NOT OPERATING

(“Timer” Light On/“Pump” Light May Or May Not Be On)

Causes:

- (1) Timer defective
- (2) Pump motor frozen (hums, but does not run)
- (3) Pump capacitor loose and/or defective
- (4) Pump motor defective/burned out
- (5) Low voltage

Actions:

(1) To determine if the difficulty is with the timer circuit or the pump unit, proceed as follows: Roll the unit over on its right hand side and remove the bottom cover panel. Remove the main timer relay housing from the timer block. Now remove the yellow wire from timer block terminal position 1, and reconnect it to the two brown wires at timer block position 3. Ensure the main "on/off" power switch is in the off position, and then plug the unit into its normal power source. Turn the main power switch on to test if the pump will run in this rewired condition. If the pump now runs, the problem is in the timer unit. Refer back to the Causes & Actions in paragraph D, Timer Not Operating, to determine the exact problem.

If the pump does not run in this rewired condition, the difficulty lies with the pump motor. Be sure to return the yellow wire to its proper position on the timer block terminal number 1, and to reinsert the main timer relay into the timer block. Note: There is a locating keyway on the timer relay to register the proper "terminal to contact" position. **Do not attempt to force the relay into position without aligning the proper keyway position.**

(2) On a relatively new pump, it may occasionally "freeze" if it stopped in a "top dead center" position the last time it ran. To get the pump to operate, it is necessary to provide the maximum, safe voltage surge. To accomplish this task, ensure the heater control switch is in the "Off" position. Set the timer control knob for 1 second or less. Now depress the microswitch roller knob through the hole in the front right hand corner of the unit just under the rail assembly. Be prepared to push the "Pump Reset" switch immediately if the pump does not start. Repeat this operation as often as necessary, ensuring the pump is not allowed to remain energized (i.e., "humming", but not running) for more than 1 second or 2. Allowing the pump motor to "hum" may trip the circuit breaker, and/or could cause permanent damage to the unit.

(3) On the 110v/50c and the 220v/50c vacuum pumps only, where there is an external capacitor, the pump motor will not start unless this capacitor is in a closed circuit condition. The condition of the capacitor can not be checked in any practical manner. However, one should check to confirm the two brown leads coming out of the pump housing are securely fastened to the capacitor via

the quick disconnect terminals, and the capacitor case is intact. If the capacitor appears to be properly wired to the pump motor, proceed with step 4 below.

(4) If the pump motor does not operate after the test specified in step A above, it is necessary to replace the entire pump unit. To gain access to the pump unit for removal, follow the procedures outlined in section 3, paragraph C, item 1, vacuum pump overhaul in the Owner's Manual. Also refer to section 6, figure 1.

(5) A low voltage situation to the pump is best identified by a "chugging" or laboring noise upon initial start-up. On any given Thermoform, the timer may not function first due to low voltage, while on another Thermoform, it may be the pump that non-functions first. Refer to step 4, paragraph D, of this section, Timer Not Operating, for the specific steps to be followed.

F. OVEN OVER-HEATING (Brailon over-heating, even at the minimum timer setting)

Causes:

- (1) Improper heater/timer adjustments
- (2) Heater control switch defective

Action:

(1) Refer to section 2, paragraph E, Timer/Heater Adjustments in the Owner's Manual. It is important to remember the heater switch should be the coarse adjustment, and the timer setting the fine adjustment.

(2) It is possible if the heater control switch is defective, both the inner and the outer heating coils will be operating continuously. This condition is not proper. To test the control switch, set it initially in the "Hi" position. After a warm-up period of fifteen minutes or longer, both coils should have a dark to moderate red glow. The color can be checked by the interior of the oven enclosure from the rear of the machine just above the marinite heat shield, or from the front with the oven enclosure drawn over to top of the clamp frame assembly. (Note: If the pump comes on during this test, the oven enclosure has been pulled too far

forward, closing the microswitch circuit. Reset the pump and repeat the visual examination.) Now turn the heater control switch down to a setting of 3 or lower, listening for a faint “click” from within the control switch. One should hear this “click” again as the control switch is turned back up past the 6 position. At the heater control switch of 4 or below after warm-up, the inner coil should be off a majority of the time (i.e., dark, with no glow). If both coils remain on at any setting and no “click” is heard, the heater control switch is defective and should be replaced.

G. OVEN ENCLOSURE NOT SLIDING FREELY

Causes:

- (1) Debris or foreign material in the rail assemblies
- (2) Base cabinet support angles are bent
- (3) Ball bearings and/or races are worn

Actions:

- (1) Refer to section 3, paragraph C, Lubrication of the Oven/Base Cabinet Rail Assemblies in the Owner's Manual. Clean and lubricate as outlined.
- (2) Look down the left hand and the right hand rail assemblies both from the front, and then from the top to determine the possible “bent locations”. In addition to the rails themselves, the support angle from the base cabinet should be perpendicular to the baseplate of the cabinet. The support plate is the sheetmetal part to which the outer or base cabinet rails are riveted. Straighten as required.
- (3) With proper preventative maintenance, the ball bearings and/or races should last a minimum of seven to ten years, even with constant daily use. The difficulty is that there is no practical means to measure the wear on these items. Accordingly, if steps A and B do not resolve the problem, the ball bearings and races should be replaced as a final option.

H. POOR (I.E., FUZZY) REPRODUCTION COPY

Causes:

- (1) Insufficient heat/warm-up
- (2) Non-permeable master
- (3) Major, clamp frame vacuum leak
- (4) Low pump vacuum
- (5) Vacuum hose leak
- (6) Brailon not inserted in the clamp frame properly
- (7) Damaged clamp frame and/or manifold seal

Action:

(1) Prior user history indicates that insufficient heat and/or warm-up is the cause of this problem twenty percent of the time. Refer to section 2, paragraph B, step 3 in the Owner's Manual. As indicated in this section, it will take approximately fifteen minutes or longer to reach operating temperature. Also refer to section 2, paragraph D, for data on the timer/heater adjustments that may be required.

(2) As indicated in section 2, paragraph C, step 3 of the Owner's Manual, the master being used must be of a permeable material. One can not use, as a master, a prior Brailon copy or similar plastic material through which air can not be drawn.

(3) Prior user history indicates that insufficient vacuum is the cause of poor reproduction seventy percent of the time. The vast majority of that time, it is due to a major leakage around the clamp frame assembly.

To test the clamp frame assembly for tightness, raise the clamp frame assembly and insert a single sheet of Brailon material on top of the screen manifold. Do not use a master or any other material besides the single sheet of Brailon. Close and latch the clamp frame assembly. Turn on the electrical power to the Thermoform via the on/off switch, ensuring the heater control switch is in the "OFF" position. Set the timer control knob for 1 to 2 seconds. Now using your finger, depress the microswitch knob in the small hole in the front right-hand corner of the unit, just under the rail. (See section 6, figure 1, item 90.)

As the timer completes its cycle, watch the Brailon sheet. When the vacuum pump comes on, the Brailon sheet should be “forcefully” pulled down onto the screen manifold in two seconds or less, to the point that the perforations in the manifold can be seen through the Brailon. If (a) the Brailon sheet was pulled down, but it took longer than two seconds, or (b) one hears a continuing “hissing” sound, or (c) the Brailon sheet was never forcefully pulled down onto the manifold at all, this indicates one or more vacuum leaks. (Note: Clamp frame assemblies on all new Thermoforms or factory repairs are adjusted to the point that they satisfactorily pass this test.)

A vacuum leak, in and of itself, is not necessarily bad. What is bad, is when the additional thickness of the master copy is not sufficient to compensate for the vacuum leaks. Accordingly, repeat the above test, but now insert a master copy in addition to the single Brailon sheet. If the Brailon sheet is not “forcefully” pulled down onto the master, to the point when the braille dots or other raised surfaces on the master are highly evident, then a clamp frame adjustment is required. Refer to section 5 for the specific steps to be followed on this adjustment.

(4) Refer to section 3, paragraph C, step 1 - Vacuum Pump Overhaul in the Owner's Manual. This section outlines the minimum vacuum requirements and the means of measurement.

(5) If the vacuum pump tests satisfactorily after overhaul but poor copies are still being produced after machine reassembly, check to ensure the rubber vacuum hose has been properly tightened. To accomplish this task, roll the unit over on its right hand side and remove the bottom cover panel. First remove the vacuum hose completely and test for soundness. This test can be done by applying air pressure (via one's mouth) to one end, while blocking the other end with one's finger. If the rubber hose seems to leak, replace with a new hose assembly. Reinstall the threaded portion securely back into the baseplate, using teflon sealing tape as required. Ensuring the forty-five degree brass fitting in the pump inlet port is also tight, reassemble the swivel fitting end to the pump fitting. Teflon tape should not be used on this union type joint.

(6) To obtain the proper vacuum, it is necessary that the Brailon sheet on top of the master be secured under all edges of the rubber clamp frame seal. If one does not insert the Brailon sheet squarely against both the left and the upper

rubber edges of the screen manifold, a gap or vacuum leak may result. This can be checked by looking for visible indications of the master copy, with the Brailon sheet on top, once the clamp frame is closed.

This problem is more prone to occur when prepunched Brailon is being used. If the prepunched holes can not be positioned under the rubber seal in the normal position of the Brailon sheet, each sheet may have to be repositioned slightly to compensate for this condition. This may also require rotation of the master copy and Brailon sheet, with the prepunched holes being located to the bottom of the clamp frame rather than the top.

(7) To maintain a good vacuum, the rubber seal around the bottom of the clamp frame, and especially the two rubber ribs on the bottom of the screen manifold must be continuous and free from damage or dirt. Inspect and clean or replace as required.

SECTION 5

CLAMP FRAME ADJUSTMENT

Although most users experience years of trouble free service from their Thermoform machine, the most frequent difficulty, when one occurs, is from a vacuum leak around the clamp frame assembly. Accordingly, a separate section has been devoted to providing instruction in the correction of this problem.

1. If the user has more than one Thermoform, check to see that the serial number on the clamp frame assembly matches the serial number of the unit. The serial number of the clamp frame is stamped on the top of the front aluminum cross piece on the frame, while the serial number for the unit is stamped on the nameplate on the right hand side of the machine.

Each frame and manifold, or series of multi-sized frames and manifolds, are custom fit to each machine. Accordingly, although a clamp frame and its manifold from one machine may work on another machine, it is by chance only and not by design. This matched clamp frame/screen manifold/unit serialization should be observed at all times.

2. An important point to remember throughout this section on clamp frame adjustments, is the objective. That objective is to obtain a condition where the Brailon sheet is “forcefully pulled down over the screen manifold” without any points of heavy resistance on the test strip. Minor gaps, as one will read about in steps 6 and 7, are acceptable, and need not be adjusted for as long as the objective is met.

3. Begin by raising the clamp frame and removing the screen manifold.

Inspect the aluminum baseplate for deep scratches around the manifold sealing area. A good vacuum can still be drawn with minor imperfections. Deep gouges, etc. must be blended out with fine emery paper and then fine steel wool. All debris and other foreign residue materials must be removed with lacquer thinner or a similar strong solvent.

Inspect the vacuum port in the middle, lower third of the baseplate. Although unlikely, any foreign material should be removed with a pair of tweezers.

4. Inspect the bronze bushing on the yoke assembly. This bushing should rotate freely and have no flat spots. If a flat spot has developed, the yoke bushing should be replaced. Refer to section 6, figure 1, for assistance in disassembly. (Note: This flat spot is the result of too much clamp frame pressure, indicating an adjustment is necessary.)

5. Inspect the bottom side of the screen manifold for torn areas of rubber, debris, etc. It is essential both the inner and the outer ribs on the bottom side be continuous (i.e., fully intact) around the complete perimeter of the screen manifold. The small 2" x 3" perforated support plate should be securely spot welded in place. Replace the screen manifold if defective. Again, any foreign material should be removed with lacquer thinner.

Reinstall the screen manifold on the top two locating pins in the baseplate. The raised molded edges should go to the left and top of the baseplate. (Note: The 21 x 29.7cm or DIN A4 manifold installs to the metric size baseplate by inserting the retaining pins to the screen, into the two drilled holes.)

Gently push around the edges of the manifold with one's finger to check if it is sitting flush on the baseplate. If a deflection greater than approximately one thirty-second of an inch (0.030", or the thickness of a standard paper-clip) is found, the screen should be straightened. To accomplish this task, remove the screen manifold and gently bend it between your thumb and fingers. Do this with extreme care since the screen is quite flexible and only requires light pressure. Also exercise caution in that the screen is not "over-straightened" in so many places along a given side that it becomes wavy.

Reinstall the screen manifold once it lays relatively flush with the baseplate.

6. Lay a fresh sheet of Brailon material in place over the screen manifold and close the clamp frame. Ensure the two clamp frame retaining pins are in place in the rear lugs of the baseplate.

Cut a test strip of Brailon material approximately one (1) inch wide by seven (7) inches long. Now:

(A) Open, and raise by approximately one (1) inch, the clamp frame with one hand;

(B) Insert the Brailon test strip under the clamp frame rubber seal with the other hand by approximately one-eighth (1/8) to one-quarter (1/4) of an inch; and

(C) Close/lock the clamp frame assembly.

Now attempt to pull the test strip out from between the clamp frame rubber seal and the Brailon sheet. One should experience light to moderate resistance. No resistance indicates a gap, whereas heavy resistance indicates too much pressure.

Repeat this insertion, close, and pull test sequence at three to four points around each of the four sides of the clamp frame. A minimum of fourteen points should be checked on the 8.5" x 11" frame, while 27cm x 34cm may require as many as eighteen points.

7. If the pull test variances are graduated (i.e., go from one extreme to the other in a linear pattern), then adjustment of the clamp frame assembly is relatively simple as indicated in the following diagrams:

Test strip pull resistance: N = None, L = Light, M = Moderate, H = Heavy,
VH = Very Heavy

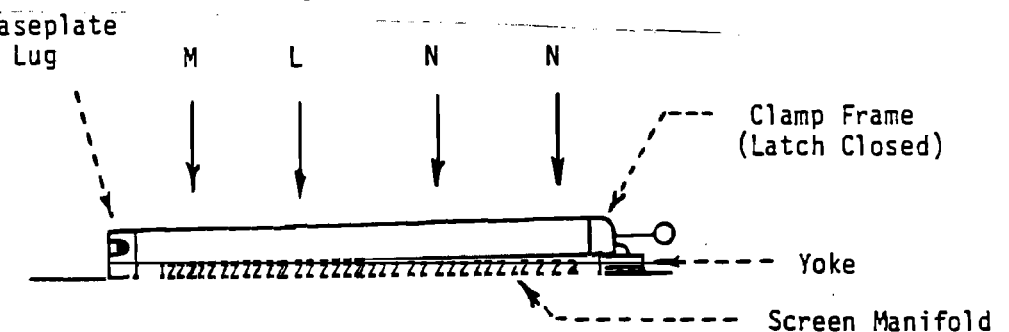

(A) To correct: remove one or more yoke shims.

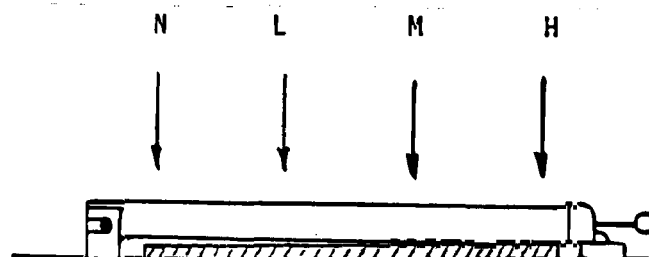

(B) To correct: lower the rear section of the clamp frame. Front shim(s) may be required.

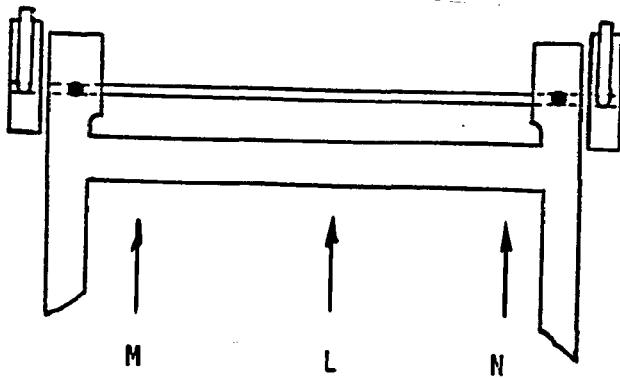

To correct: Lower the right hand corner of the frame

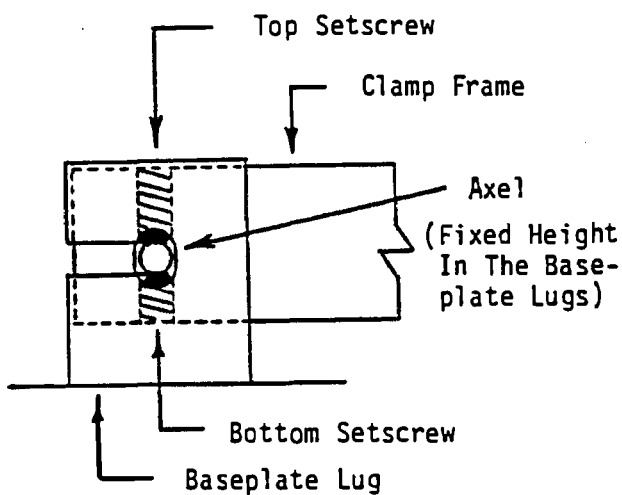

To Lower (tighten) the clamp frame: loosen the top set-screw and tighten the bottom.

To Raise (loosen) the clamp frame: loosen the bottom set-screw and tighten the top.

Notes:

- A. To adjust, use the 3/32 across the flats, hex wrench initially provided with each Thermoform.
- B. A point to remember, the clamp frame will move opposite the direction of the set-screw being loosened.
- C. When adjusting the set-screws, just break the grip and do not rotate more than one-quarter turn. Then take up on the opposite set-screw. This apparent minor change will have a significant effect on the fit.

8. If the variances along any given side are non-graduated as indicated below, then the clamp frame is warped or bent. This warping can be the result of being dropped, too much heat for an extended period of time, etc. Unless local personnel are experienced in this type of repair, this condition usually requires factory service.

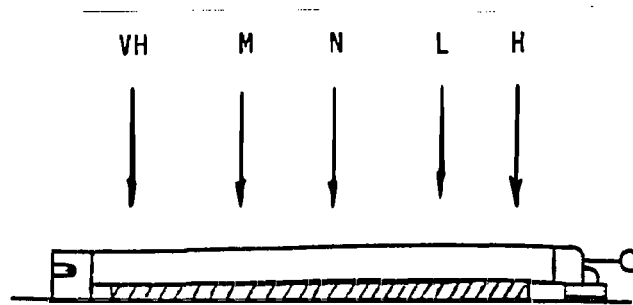

Warped frames can be straightened to a given flatness by factory service without having to return the entire machine. However, final local clamp frame adjustment per the steps outlined in steps 6 and 7 above will probably still be required. Owner's desiring this clamp frame straightening service need to return the clamp frame(s) in question, the applicable screen manifold with each frame, and the baseplate from the Thermoform machine. Prior arrangements should be made with ATC before returning any piece of equipment for repair of service.

SECTION 6

ISOMETRIC DRAWINGS & PARTS LISTS

INDEX

Figure 1 – Top Assembly Drawing & Parts List

Figure 2 – Oven Assembly & Parts List

Figure 3 – Base Cabinet Assembly & Parts List

Figure 4 – Pump Assembly & Parts List

Figure 5 – Clamp Frame Assembly & Parts List

Figure 6 – Wire Harness Diagram

Note: Multiple part numbers for a given item are because of size, voltage or amperage differences. Ensure that the proper part number is selected when ordering replacement parts.

AMERICAN THERMOFORM CORPORATION EZ FORM MACHINE

FIGURE 1 - TOP ASSEMBLY ISOMETRIC

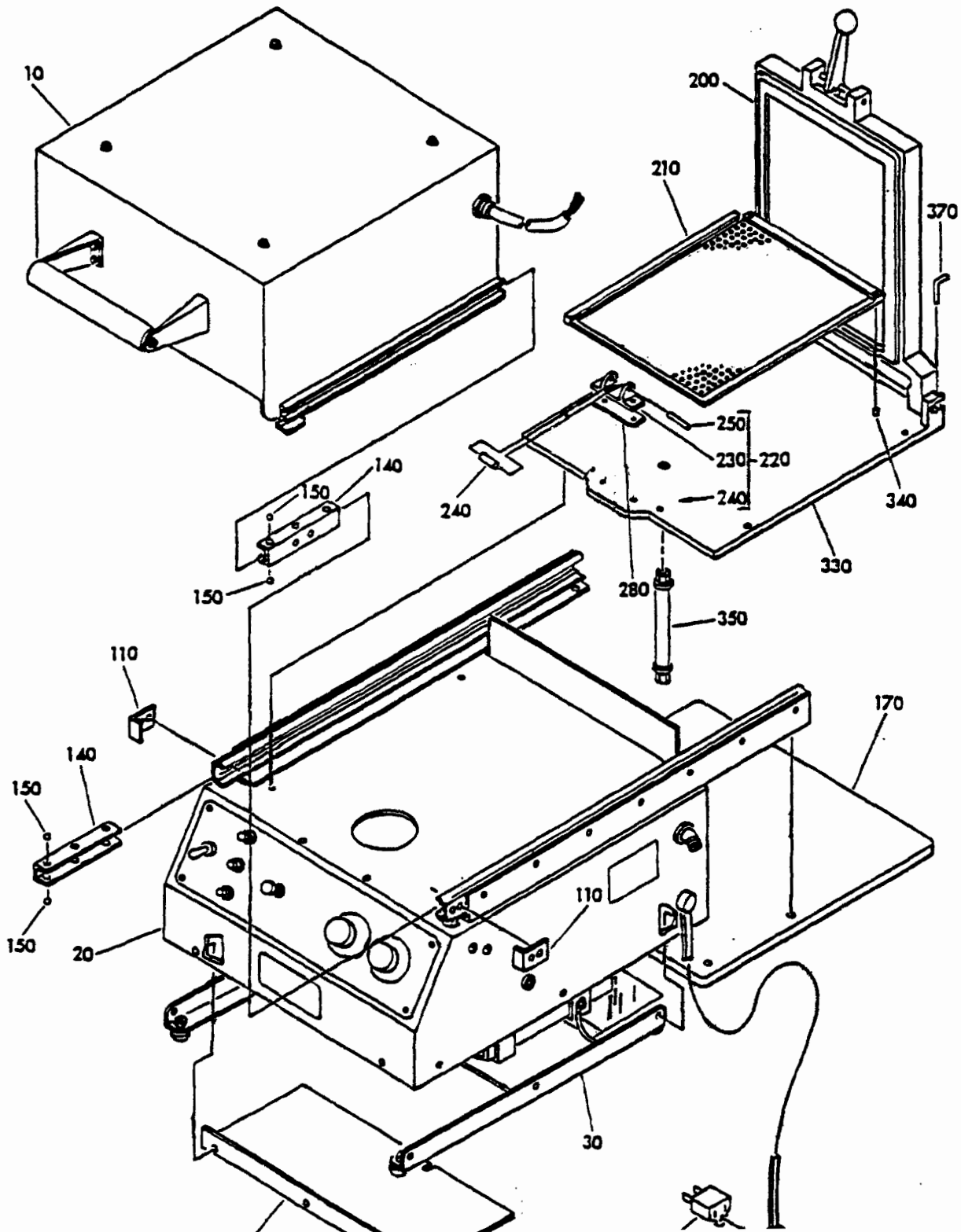

MACHINE PARTS LIST

Item	Part Number	Description
10	100MA	Oven Assy (see figure 2)
20	200MA	Base Assy (see figure 3)
30	900MA	Pump Assy (see figure 4)
-40	SP1451	Mach. Screw, 10-32 x ¼", Pan Head
-50	SP2652	Lock Washer #10
60	202	Bottom Cover Plate
-80	SP2632	Lock Washer #6
-90	SP1332	Mach. Screw, 6-32 x 3/8", Pan Head
-100	SP2630	Flat Washer #6
110	203	Oven Stop Bracket
-120	SP1333	Mach Screw, 6-32 x ½", Pan Head
-130	SP2332	Nut, Hex 6-32
140	803	Slide Race, 3 Ball
150	805	Slide Balls – 5/16"
160	223	3-Prong Adapter (115v units only)
170	225	Marinite Heat Shield
-180	SP2670	Flat Washer ¼"
190	SP2453	Wing Nut, 10-32
200	Various	Clamp Frame Assy (see figure 5)
210	Various	Screen Manifold (size varies per machine)
220	500A	Yoke Assy
230	501	Yoke Casting Pin Machined
240	502	Yoke Bushing
250	503	Yoke Pin
-260	SP1851	Set Screw, 10-24 x ¼" Hex
-270	SP1143	Mach Screw, 8-32 x ½" Oval Head
280	Various	Yoke Shims Brass
330	550A	Standard Size Baseplate (used with english size clamp frames)
-330	556A	Oversized Baseplate (used with metric size clamp frames)
340	554	Screen Manifold Retaining Pin, ½ x 1/8"
350	920A	Vacuum Pump Hose Assy
370	553	Clamp Frame Retaining Pin
-380	815	Frame Adjusting Hex Wrench

-390	SP3451	Wire Joint Connector, Small
-400	SP3453	Wire Joint Connector, Medium
-410	SP3455	Wire Joint Connector, Large
-420	SP3301	Ty-Wrap, Electrical (small)
-430	SP3303	Ty-Wrap, Electrical (large)
-440	SP6111	Dow Corning Silicone Grease Compound #7

- ITEMS NOT ILLUSTRATED

MACHINE PARTS LIST

Item	Part Number	Description
-01	100MA	Oven Assy-115v/220v
10	101	Oven Enclosure
20	102	Bracket, Oven Handle-L/H
30	103	Bracket, Oven Handle-R/H
-50	SP2632	Lock Washer #6
60	104	Oven Handle (wood)
-80	SP2652	Lock Washer #10
90	105/106	Heating Element 115v&220v 1300w, Dual Coil (105 used on 115v, 106 used on 220v)
-110	107	Heater Reflector
130	109	Ceramic Stand-off
-140	SP1332	Machine Screw, 6-32 x 3/8", Pan Head
-150	SP2630	Flat Washer, #6
-160	SP2632	Lock Washer #6
170	110	Oven Insulation Kit
180	110-1	Oven Insul-top PC, 14" x 15"
190	110-2	Oven Insul-PR/5K PC, 12" x 4.875"
200	110-3	Oven Insul-Left PC, 14.75" x 4.875"
210	110-4	Oven Insul-Right PC, 14.75" x 4.875"
-230	SP2143	Nut, Hex 8-32
240	651	Oven to Base Wire Kit
250	653	Flex Conduit w/nuts
260	658	Elect. Elbow, Straight
-270	655	Hex Nut, 3/4" Elect.
-280	657	Lock Washer, 3/4"
290	802	Oven Slide, Inner Rail
-300	SP1933	Rivet, Monel-Flat Head, 3/32" x 3/16"
-310	SP1934	Rivet, Monel-Flat Head, 3/32" x 1/4"

- ITEMS NOT ILLUSTRATED

AMERICAN THERMOFORM CORPORATION
EZ FORM MACHINE

FIGURE 3 - BASE CABINET ASSEMBLY

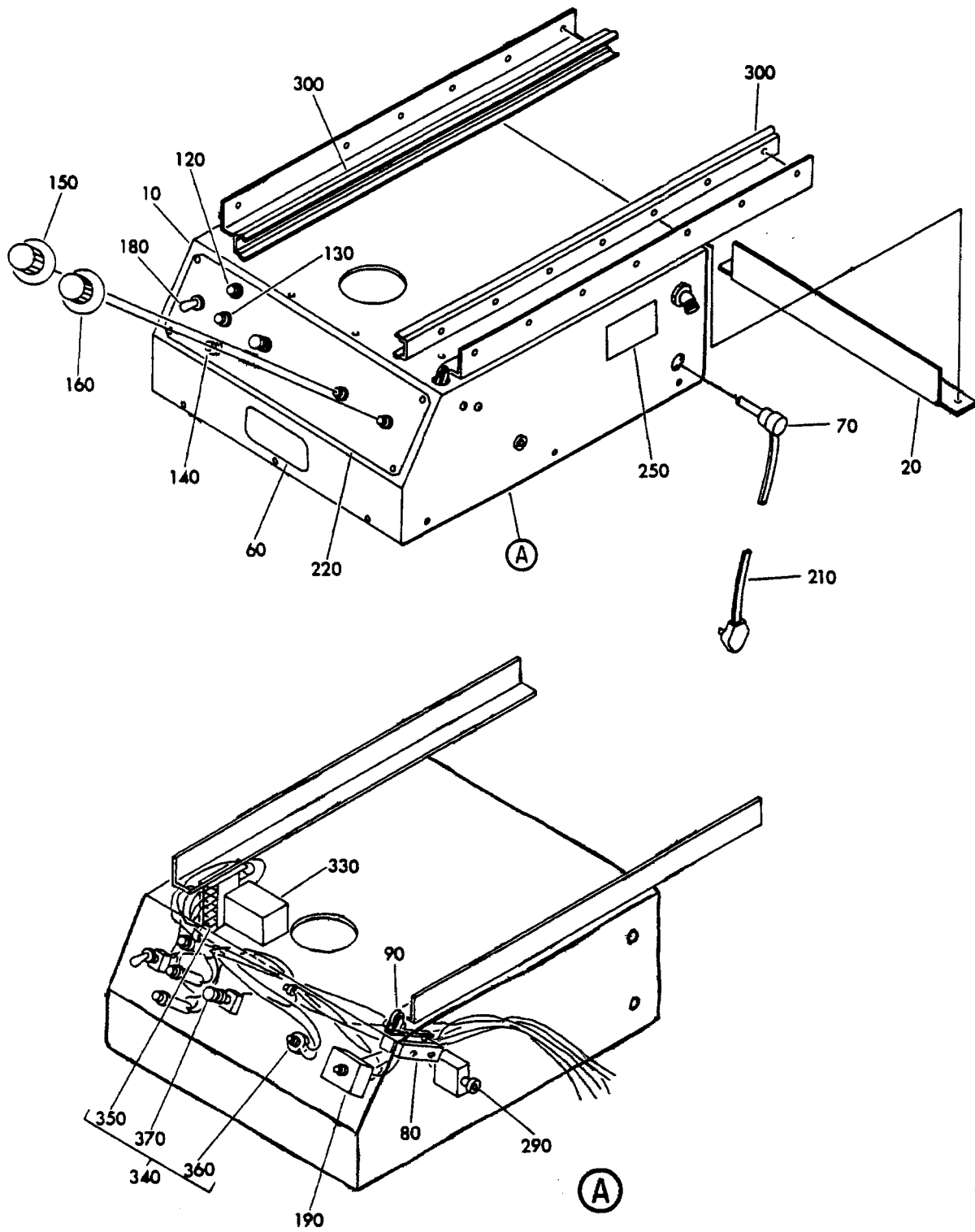

MACHINE PARTS LIST

Item	Part Number	Description
-01	200MA/115/220	Base Assy – 115v/220v/220v metric
10	230	Base Enclosure
20	204	Heat Shield, Stainless Steel
-30	SP1457	Mach Screw, 10-32 x 1”
-40	SP2652	Lock Washer, #10
-50	SP2153	Nut, Hex 10-32
60	209	Nameplate, Aluminum
70	210	Bushing, 90 Deg-Elect
80	211	Spacer, Microswitch Alum, 2” x ½”
90	215	Microswitch, 115v and 220v
-100	SP1338	Mach Screw, 6-32 x 1-1/4”, Pan Head
-110	SP2332	Nut, Hex 6-32
120	264/262	Indicator Light, Green – 115v/220v (264 used on 115v, 262 used on 220v)
130	265/263	Indicator Light, Orange – 115v/220v (265 used on 115v, 263 used on 220v)
140	267/266	Indicator Light, Blue – 115v/220v (267 used on 115v, 266 used on 220v)
150	275	Knob, Timer
160	276	Knob, Heater
-170	SP1923	Rivet, Alum Round Head, 1/16” x 3/16”
180	216	Rocker Switch
190	217/218	Heater Control Switch, 115v/220v (217 used on 115v, 218 used on 220v)
210	222	Lead-in Cord
220	305	Lexan Front Plate
-230	SP1211	Mach Screw, 2/56 x ¼”
250	311	Caution Label, Aluminum
290	715/714	Circuit Breaker, 115v/220v
300	801	Base Slide Outer Rail (used on 220v and 115v machine)
-310	SP1933	Rivet, Monel-Flat Head, 3/32” x 3/16”
330	953/954	115v/220v Timer, Syracuse On-Delay (953 used on 115v, 954 used on 220v)
340	963A	Wiring Harness Assy

350	713	Timer Block
360	721	Timer Control Switch
370	951	Pump Reset Switch
-380	SP1336	Mach Screw, 6-32 x 7/8" Pan Head
-390	SP2332	Nut, Hex 6-32
-400	SP3453	Wire Joint Connector, Medium

-ITEMS NOT ILLUSTRATED

AMERICAN THERMOFORM CORPORATION
EZ FORM MACHINE

FIGURE 4 - PUMP ASSEMBLY

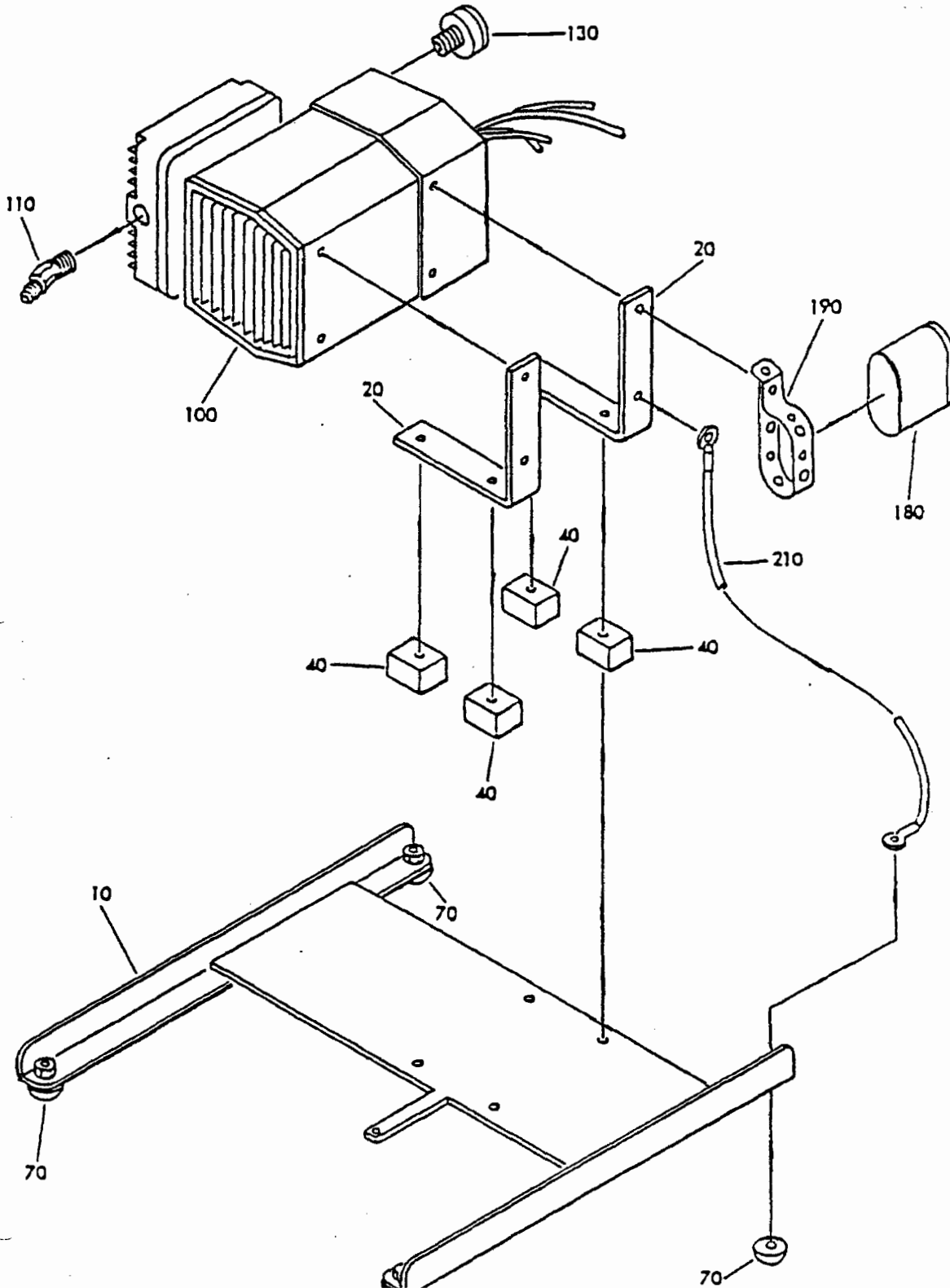

MACHINE PARTS LIST

Item	Part Number	Description
-01	900MA	Pump Assy (115v/220v)
10	901	Pump Mounting Frame
20	902	Pump Mounting Angle Bracket
40	903	Rubber Shock Mount
-50	SP1579	Mach Screw, ¼-20 x 1-1/2" Flat Head
-60	SP2370	Nut, Hex ¼"
70	302	Rubber Foot
-80	SP2153	Nut, Hex 10-32
-90	SP2652	Lock Washer #10
100	940/941	Vacuum Pump, 110v/115v/220v (940 used with 110v/115v, 941 with 220v)
110	924	Fitting, 45 Deg Elbow
130	981	Pump Silencer
-140	SP1453	Mach Screw, 10-32 x ¼" Pan Head (used on 110v/115v machine)
-140	SP1453	Mach Screw, 10-32 x ½" Pan Head (used on 110v/220v machine)
-150	SP1457	Mach Screw, 10-32 x 1" Pan Head (used on 110v/220v machine)
-160	SP2652	Lock Washer #10
-170	SP2650	Flat Washer #10
180	942-1	Capacitor, 4MFD (used on 110v/220v)
190	942-2	Capacitor Strap (used on 110v/220v)
-200	SP3416	QDC(F)-Insul, 14-250 (110v/220v)
210	961	Ground Wire (110v/220v)

- ITEMS NOT ILLUSTRATED

AMERICAN THERMOFORM CORPORATION
EZ FORM MACHINE

FIGURE 5 - CLAMP FRAME ASSEMBLY

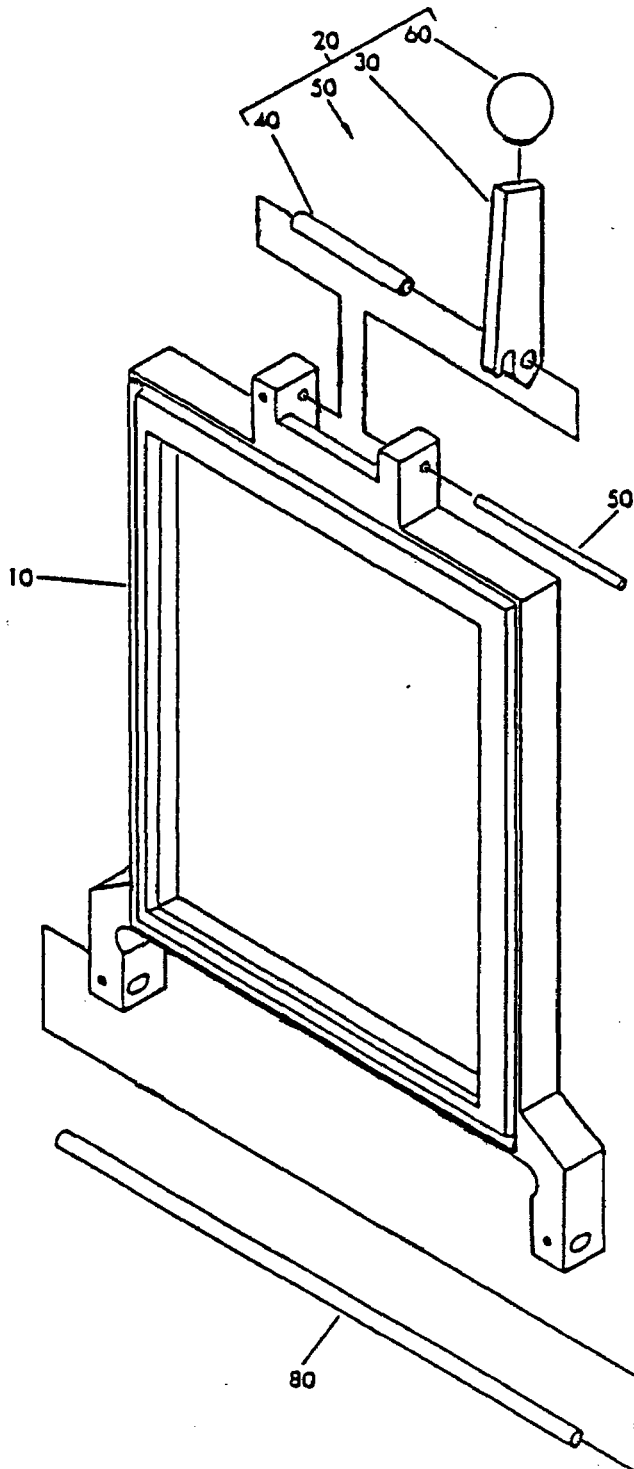

MACHINE PARTS LIST

Item	Part Number	Description
-01	Various	Clamp Frame Assembly (various sizes)
10	Various	Clamp Frame (various sizes)
20	412A	Latch Handle Assy
30	413	Latch Handle
40	414	Latch Handle Sleeve
50	415	Latch Handle Pin
60	416	Knob, 1" Dia
-70	SP1865	Setscrew, 1/4"-20
80	410	Frame Hinge Axle
-90	SP1851	Set-screw, 10-24" x 1/4" Hex
-100	SP1852	Set-screw, 10-24" x 3/8" Hex

Note: As a replacement part, the 415 Latch Handle Pin is not provided as part of the 412A Latch Handle Assy. If required, part number 415 must be ordered as a separate item.

- ITEMS NOT ILLUSTRATED

AMERICAN THERMOFORM CORPORATION
EZ FORM MACHINE

FIGURE 6 - WIRING HARNESS DIAGRAM

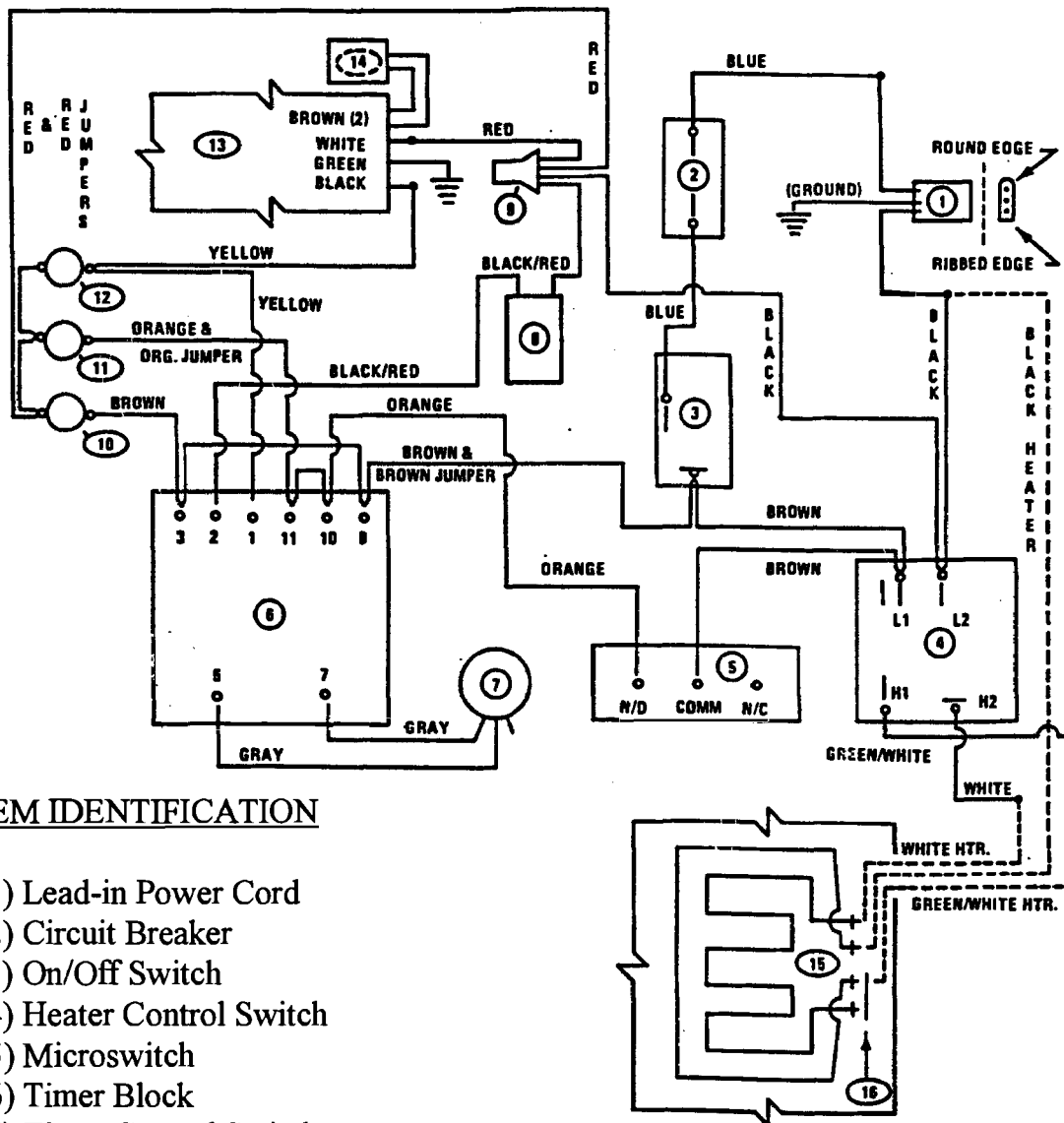

ITEM IDENTIFICATION

- | | |
|---------------------------------|--------------------------------|
| (1) Lead-in Power Cord | (14) External Capacitor |
| (2) Circuit Breaker | (110v & 220v, 50c units only) |
| (3) On/Off Switch | (15) Dual Element Heating Coil |
| (4) Heater Control Switch | (16) Buss Bar |
| (5) Microswitch | |
| (6) Timer Block | |
| (7) Timer Control Switch | |
| (8) Pump Reset Switch | |
| (9) Wire Joint | |
| (10) Main Power Indicator Light | |
| (11) Timer Indicator Light | |
| (12) Pump Indicator Light | |
| (13) Vacuum Pump | |