

# BRAILLO 400 S

## Series 3



## User's Guide



## TABLE OF CONTENTS

1.	PRINTER BASIC .....	5
2.	INSTALLATION .....	6
2.1	Unpacking .....	7
2.2	Removal of cover .....	8
2.3	Removal of transport locks .....	11
2.4	Mounting the paper shelves .....	12
2.5	Connecting the printer to the mains and computer .....	13
2.6	Turn on the printer .....	15
3.	OPERATING THE PRINTER .....	16
3.1	Inserting paper .....	16
3.2	Operating panel functions .....	17
3.3	Print values .....	22
3.4	Messages and error messages .....	24
3.5	Test print .....	28
3.6	Self-test on magnets .....	29
4.	SERVICE AND MAINTENANCE .....	31
4.1	Printing principle .....	31
4.2	Troubleshooting, incorrect braille .....	37
4.3	Magnet rack, removal .....	40
4.4	Magnet rack disassembly, step by step .....	41
4.5	Magnet, replacement .....	43
4.6	Magnet rack, cleaning .....	46
4.7	Magnet rack, adjustment .....	47
4.8	Magnet rack, refitting and adjusting .....	49
4.9	Beam and papershoes, overview .....	55
4.10	Beam and papershoes, removal and refitting .....	56
4.11	Beam, replacement of short pivot arm .....	58
4.12	Beam, replacement of printing pin .....	59
4.13	Return spring, adjustment .....	60
4.14	Eccentrics, adjustment .....	61
4.15	Paper shoes, adjustment .....	62
4.16	Main sensor wheel, adjustment .....	63
4.17	Paper feed assembly, adjustment .....	64
4.18	Inductive sensors, adjustment .....	65
4.19	Paper sensor, replacing .....	66
4.20	Maintenance .....	67
5.	PARTS - EXPLODED VIEWS .....	69
5.1	Magnet rack .....	69
5.2	Beam .....	70
5.3	Paper shoe .....	71
5.4	Paper feed .....	72
5.5	Shafts, belt .....	73
5.6	Frame .....	75

6.	TECHNICAL SPECIFICATIONS.....	78
6.1	Technical specifications.....	78
6.2	Electric unit, overview.....	79
6.3	Pin configuration external connection.....	81
6.4	Main board, connections, schematics.....	82
6.5	Magnet rack board, schematics.....	85
6.6	Operating panel.....	86
6.7	Pin configuration serial and parallel port.....	87
6.8	Escape-sequences.....	89
7.	GENERAL INFORMATION.....	94
7.1	Declaration of conformity.....	94
7.2	Warranty.....	95
	Warranty request form.....	96
7.3	Adresses and phone numbers.....	97

## 1. PRINTER BASIC

Thank you for your purchase of a Braillo 400 S series 3. Please read this manual carefully before installing and operating this printer.

### Features

Prints interpoint, both sides of the page are printed simultaneously.

Prints 400 characters/second, which gives about 1200 pages/hour (with a 12-inch sheet).

Self-test system that checks the magnets continuously during printing.

Reliable, sturdy construction.

Safety switches that will turn off the printer if somebody accidentally opens the cover.

### Printer overview

Please see the figure below:

Note that the “right-hand” and “left-hand” side are referred to as if you were standing behind the printer facing the opening where the paper is inserted into the printer.

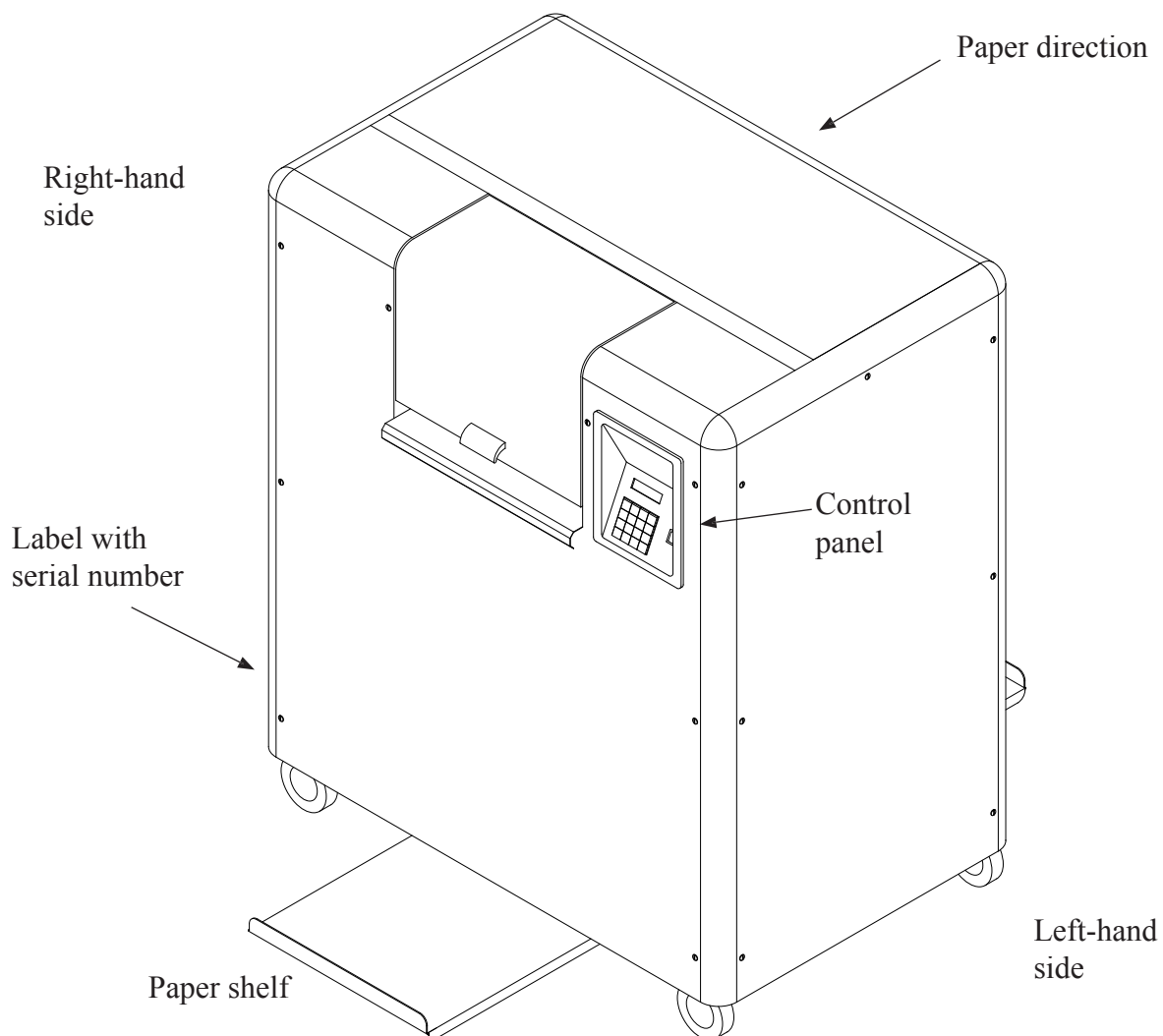

## 2. INSTALLATION

### Space:

The minimum space required for the Braillo 400 S is approximately 1.25m x 1.5m (4 x 5 feet). It can be useful to have more space behind the printer so that one can replace the boxes of paper.

### Distance to the computer:

Serial communication: Up to 25 metres (cable distance) from the computer without special transmission precautions.

Parallel communication: Up to 7 metres (cable distance) from the computer without special transmission precautions.

### Environment:

Braillo printers are made to operate continuously and to be reliable for many years. However, sensitive electronic and mechanical parts require a suitable installation environment to ensure long and trouble-free operation.

Failure to meet the installation requirements may relieve the supplier of any warranty responsibilities. Temperatures between 15 - 30 C (60 - 86 F), and relative humidity between 40 and 60%.

Maintain a clean environment because dust may clog the printer - especially with high humidity. Too low humidity should also be avoided to prevent electrostatic problems.

Some paper qualities may generate excessive paper dust. This should be removed with a vacuum cleaner and a damp cloth. (About every 50,000 Sheets).

Be sure to consult your distributor/supplier for further details concerning the installation site.

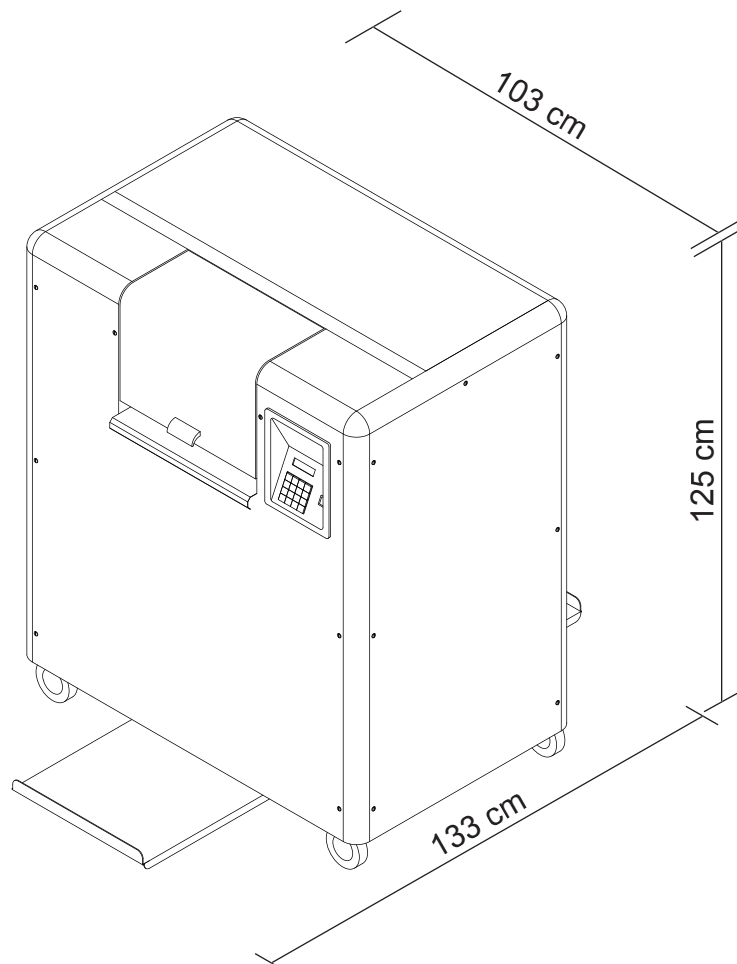

## 2.1 Unpacking

Unpacking and installation can be done by the user.

After unpacking the printer, the cover must be removed before lifting the printer. See chapter 2.2 “Removal of Cover”.

Any kind of lifting of the printer must always be done from the baseboard at the bottom of the printer, or from the steel frame, and should be done with extreme care.

Make sure that your Braillo printer has not been damaged in transport. Check if the packing is damaged; If so, it is possible that the printer has also been damaged or scratched. If any damages are found, please contact your distributor or Braillo Norway AS immediately.

Also check that the printer is accompanied with the following items:

- 1 Power cable for the printer
- 2 Data cables (serial and parallel)
- 1 Serial adapter (9-25 pin)
- 1 A small stack of paper
- 1 User's guide
- 1 Toolkit for service and maintenance
- 2 Paper shelves with screws
- 1 Test and packing list

If any of these items are missing, please contact your distributor or Braillo Norway AS.



### **Important !**

It is very important that the printer's specified voltage value (220V, +/- 10%) corresponds with the local mains power supply available.

If the plug on the mains power cable is to be replaced, note that the yellow/green wire is the grounding (earthing) wire.

After the printer is unpacked, make sure that the transport box is kept for eventually later use.

## 2.2 Removal of cover

See figures below and on the next pages.

The cover is constructed of a aluminium frame which is fastened with four screws (G) under the baseboard of the printer, there are one screw in each corner. Onto this frame the sides, front and back t panels are fastened. Some of these panels can be taken off for a better access e.g. for smaller repairs or to connect to the electrical unit.

However, if the printer is going to be lifted or moved, and the printers own wheels cannot be used, the cover must be taken off completely.

It can be done like this:

Disconnect the mains.

Open the panel (A) by turning the seven screws (B) 1/4 of a revolution - use a coin or a screwdriver.  
Pull out the panel. Place it aside.

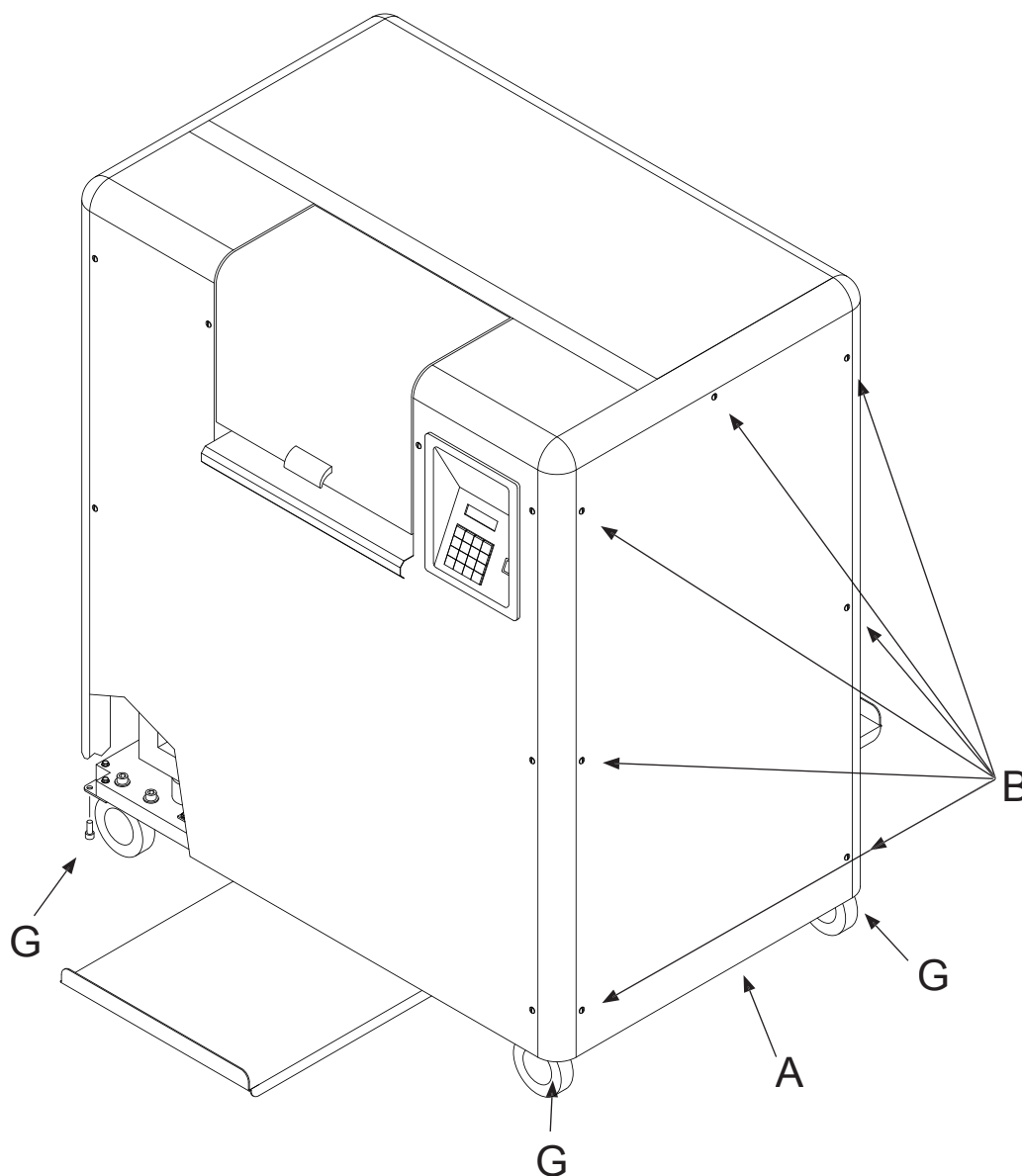



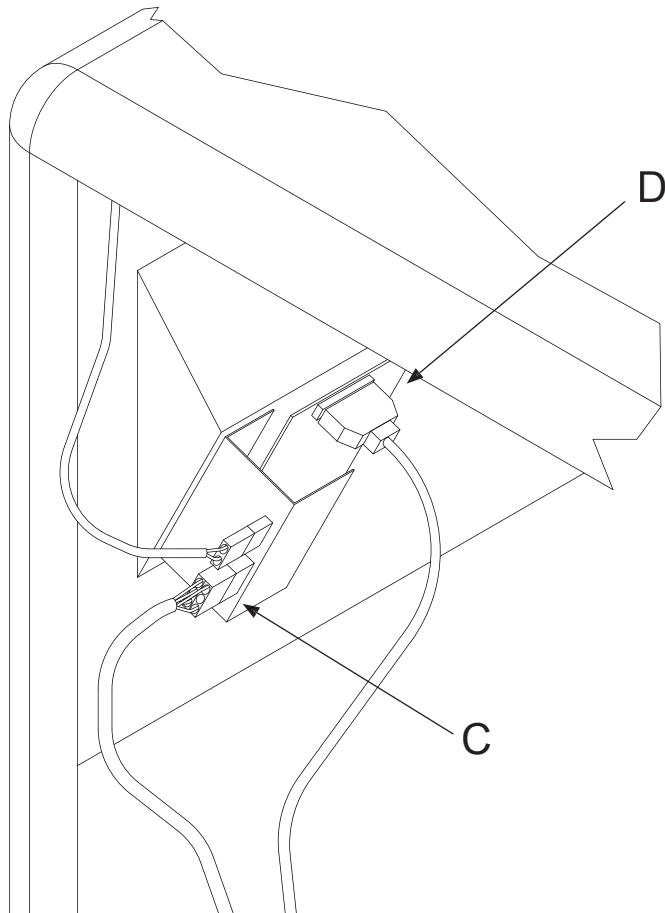

Disconnect the cables to the on/off switch (C) and operating panel (D). Note that these cables is to be disconnected at the end on the back of the operator panel.

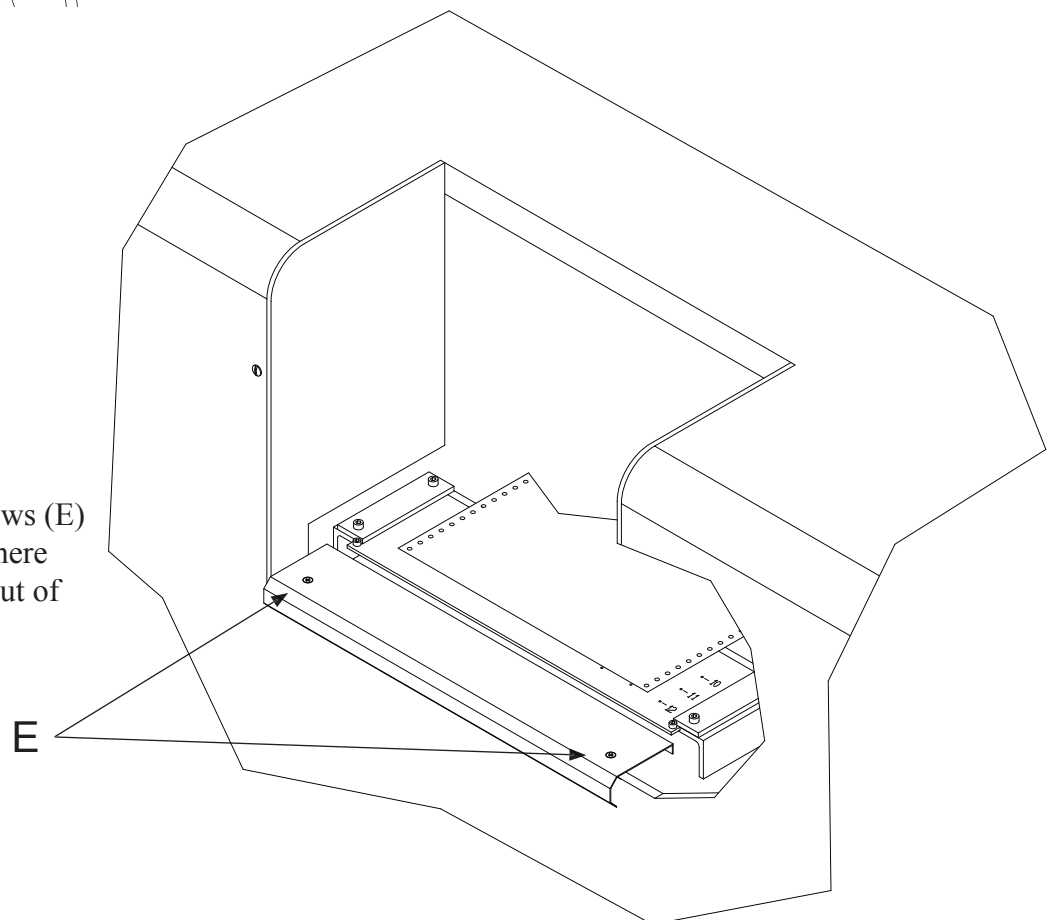

Unscrew the two screws (E) on the paper guide where the paper is coming out of the printer.

Then disconnect the cable to the fan (F). The cable to the fan is to be disconnected on the electrical unit.

Then unscrew the four screws (G) (use a 6 mm allen key) and lift the cover upwards very carefully. The printer can now be moved to the desired location.

Please observe that it is possible to lock the wheels to secure the printer when it is positioned.

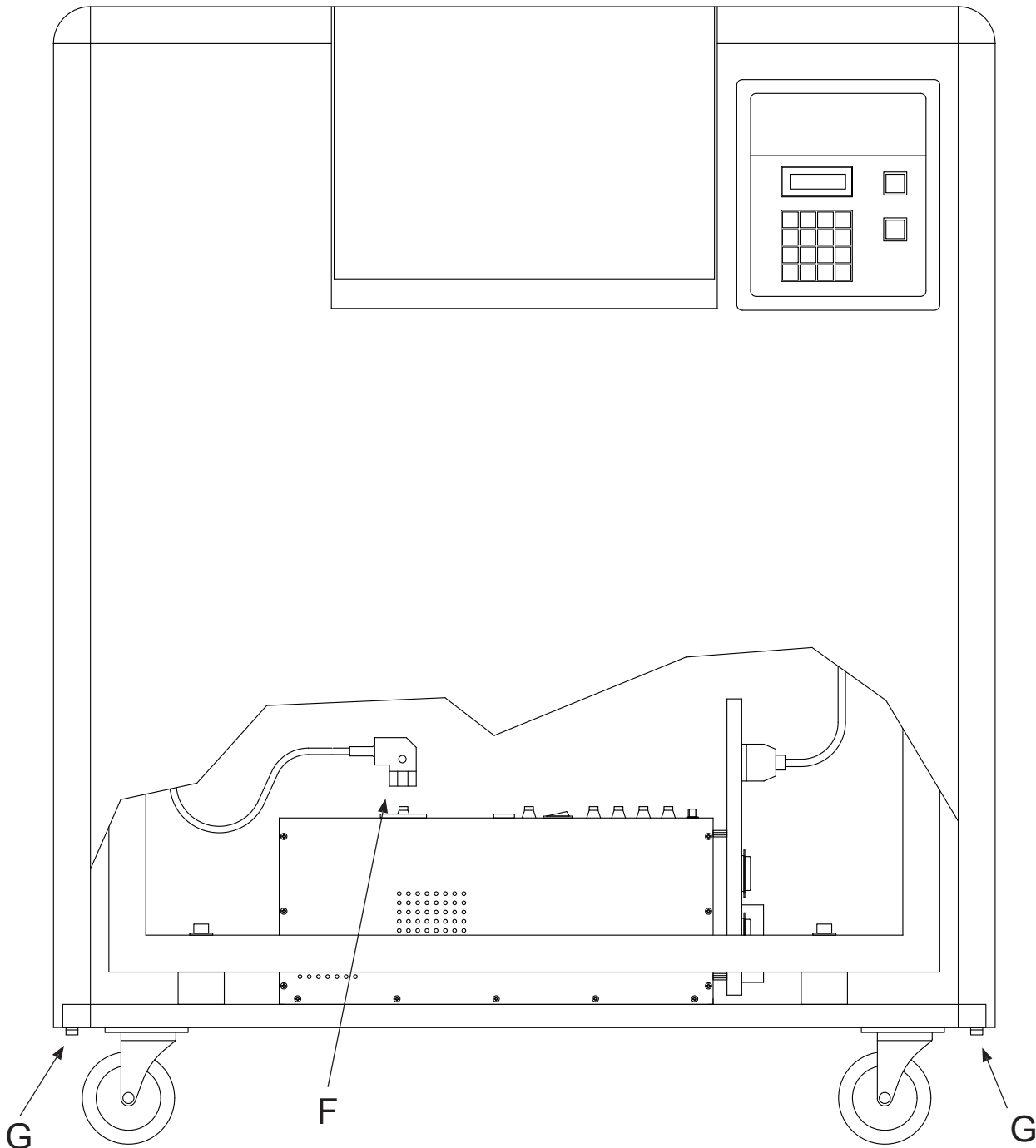

### 2.3 Removal of transport-locks.



**This printer has eighth transport-locks. All eighth must be removed before starting the printer!**

There are four between the baseplate and the steel frame, and four between the steel frame and the printing mechanism.

Please see figures below:

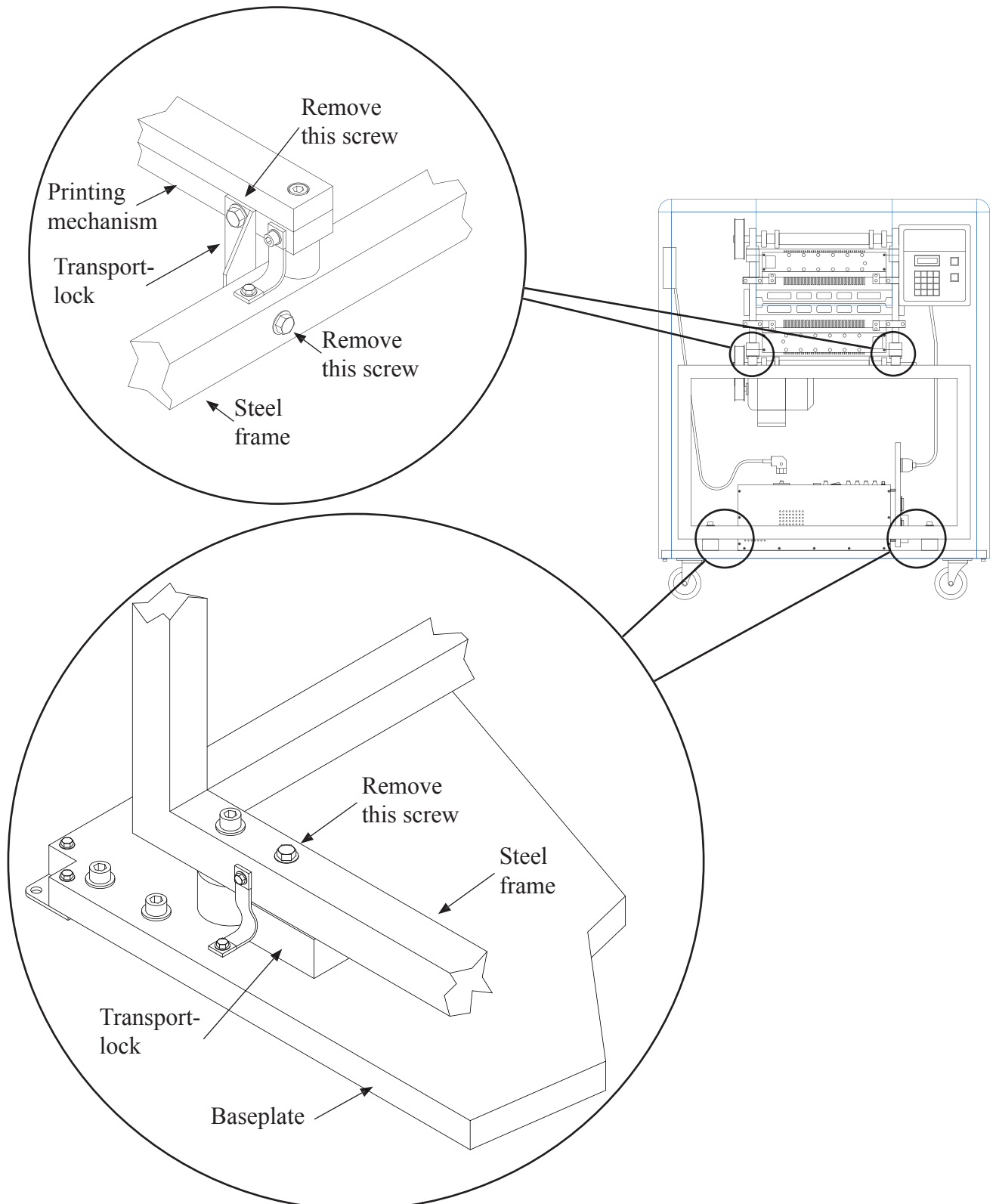

## 2.4 Mounting the paper shelves.

See figure below.

There are two black paper shelves with screws enclosed with the printer. They are supposed to be mounted as shown on the figure below, one on each side.

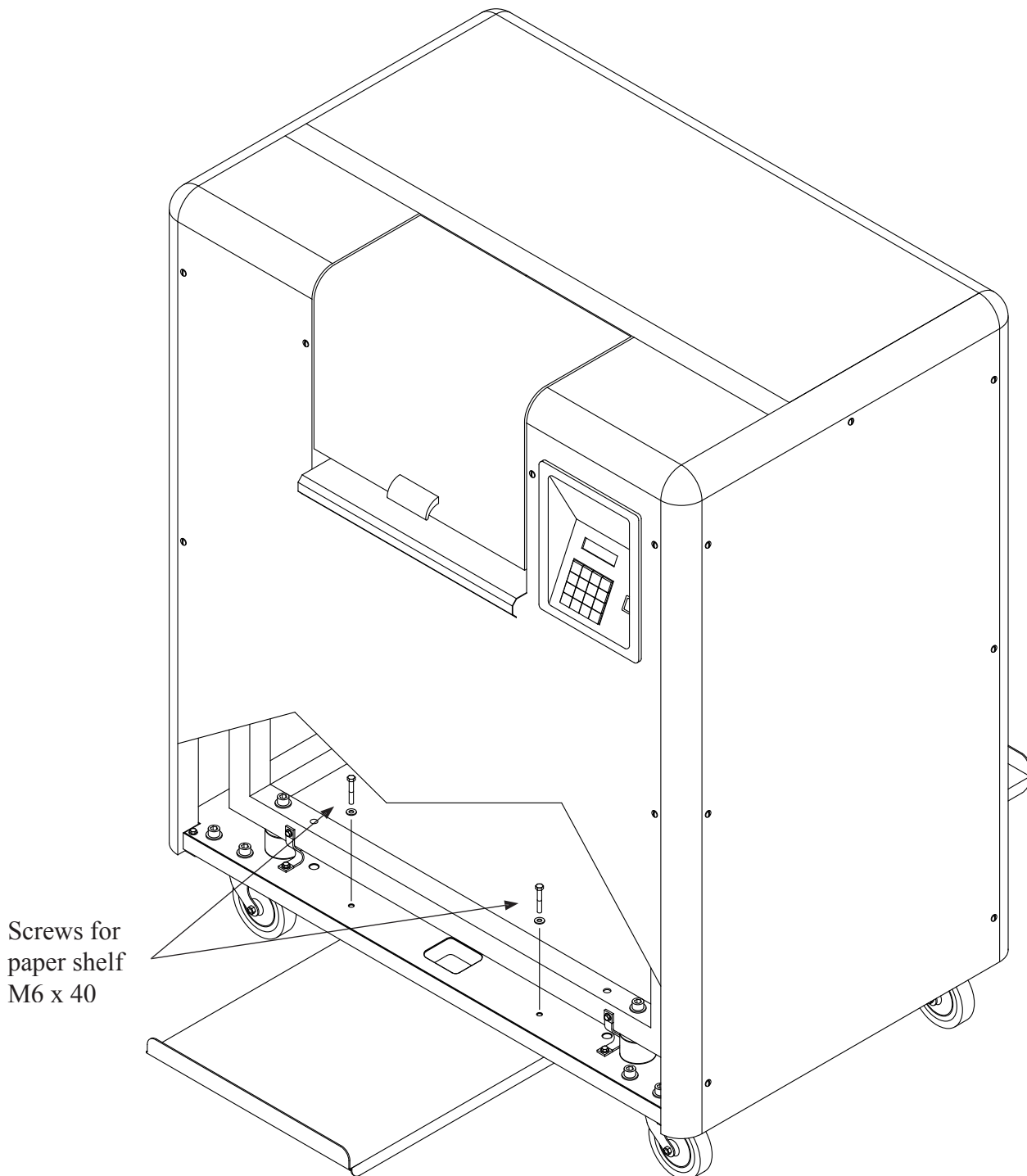

## 2.5 Connecting the printer to the mains and computer.

The connections are inside the printer, on the electric unit.

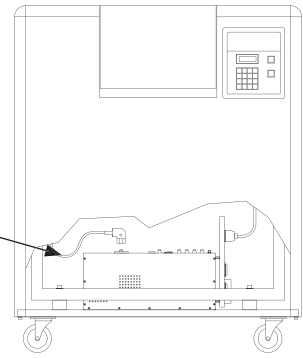

### Connecting to the mains

See the figure below, this is a top view of the electrical unit.

Connect the enclosed mains power cable to the Mains inlet.

Note! If the plug on the mains power cable is to be replaced with one that is compatible with the local electric contact points, observe that the yellow/green wire is the grounding (earthing) wire. Also make sure that you are connecting to 230 volts!

**THE PRINTER MUST ALWAYS BE CONNECTED TO GROUND!**

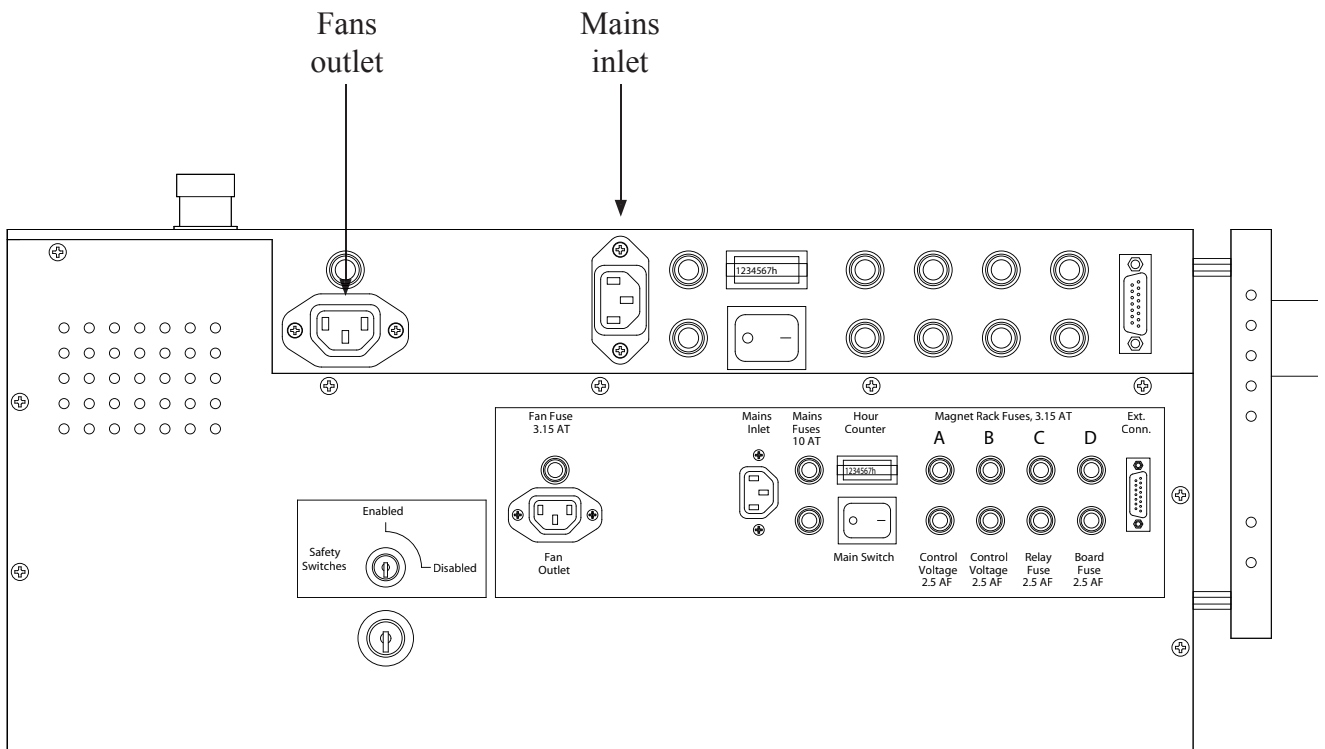

### Connecting to the computer

This can be done in two ways, either parallel or serial.

The serial communication uses the RS 232 interface and the parallel communication uses the Centronics interface. Both connectors are of the 25 pin D-Sub type.

See figure below, this is a side view of the electrical unit.

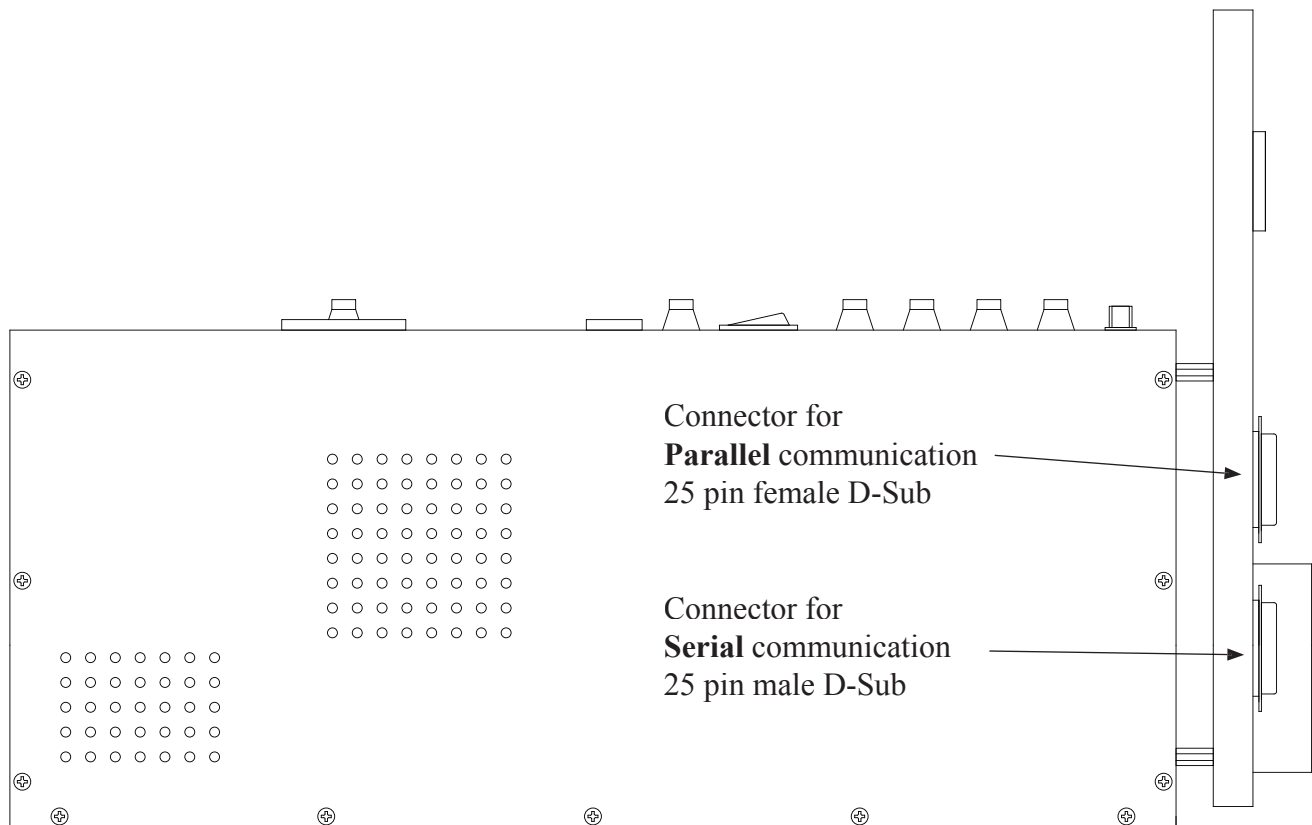

## 2.6 Turn on the printer

After the mains cable and the serial/parallel cable has been connected, the printer on can be turned on.

 For safety reasons, there are switches on each side panel on the cover. These switches will turn the printer off if somebody is removing the side panels.

However, when doing service and maintenance it is possible to bypass these safety switches. It is done with the key switch on the electric unit. See figure below:

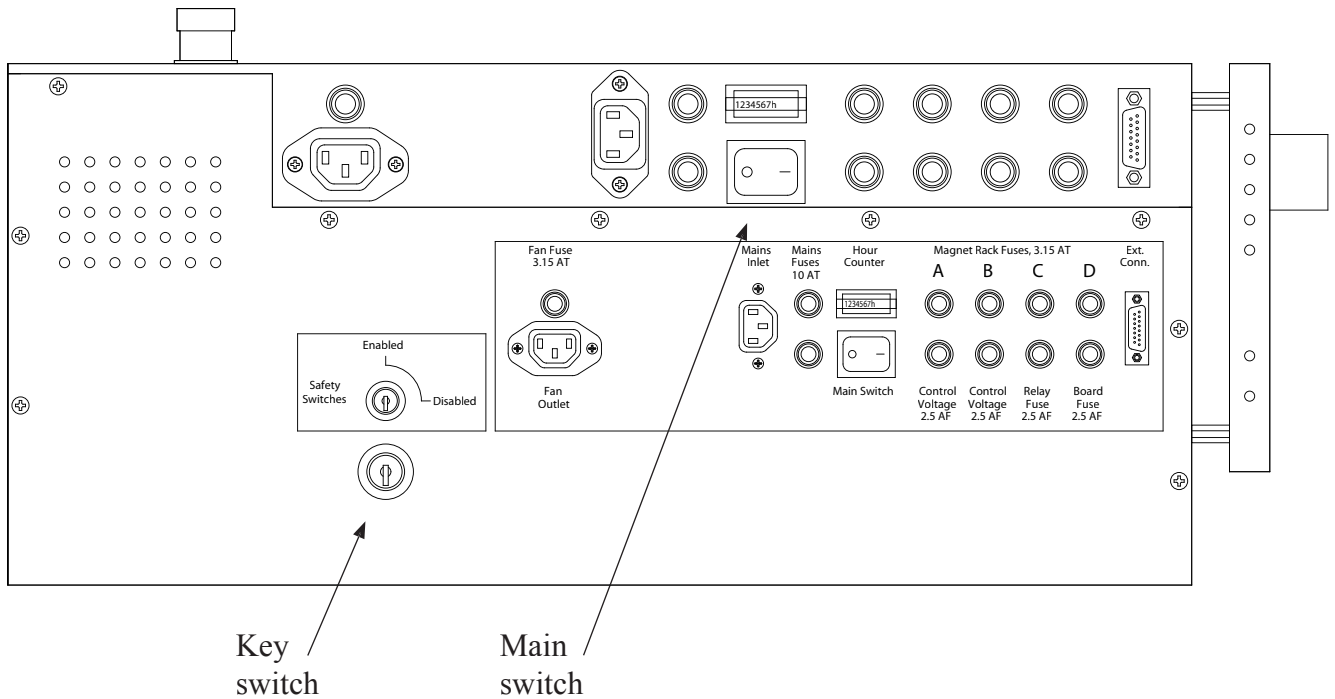

If this key switch is turned to:

“Disabled” The safety switches and the On/Off switch is bypassed and the printer will stay on independent of the On/Off switches. The Main switch can be used to turn the printer on and off during **service and maintenance**.

“Enabled” This is the **normal position**. Now all four sidepanels has to be in place and the printer is turned on and off with the On/Off switches.

Turn on the main switch. It will now be illuminated. This switch can normally be left on all the time. Put the side panels on the cover back on.

Press the green “on” switch beside the operator panel. The switch will become illuminated, and there will be background lights in the display.

Then the printer will do a little “startup procedure” (the paper feed tractor will move a little back and forth). If there is no paper inserted, the printer will start to “beep”, and the display reads “Printer Out of paper”. This is normal, and the noise can be silenced by pressing the button marked “Reset Alarm”.

The printer is now ready. Now please read the following chapter 3, “Operating” carefully.

### 3. OPERATING THE PRINTER

#### 3.1 Inserting paper

Paper should be inserted into the printer in the following manner:

1. Press the “on” switch, if the printer is not already switched on. (Green power lamp lights up).
2. Place a box of paper on the paper shelf at the back of the printer. (Opposite side from the operating panel).
3. Insert the paper between the two paper guides, and then through the slit in the paper guide. Insert about the length of one sheet. Go to the front of the Printer.
4. The tractors might have to be adjusted sideways to fit to the paper width in use. This is done by loosening a little red screw at the front of the tractors, then move the tractors so it will fit to the paper width, then thighten the little red screw again.
5. Lock the paper into the tractor-feed. By using the FINE ADJUST button, adjust the paper with respect to the starting mark (notch) corresponding to the chosen sheet length. (See figure below).
6. Go to the back of the printer, and adjust the two paper guides carefully close to the edge of the paper. This is to ensure that the paper will go straight trough the printer.
7. Push RESET PRINTER.
8. Push RESET COUNTER, if desired.
9. The printer is now ready to start printing.



Note! If the printer has run out of paper during a printjob, perform step 2 to 5, without resetting the printer. Press the TEST PRINT button in and out, and the printer will continue from the place where it ran out of paper without losing any text.

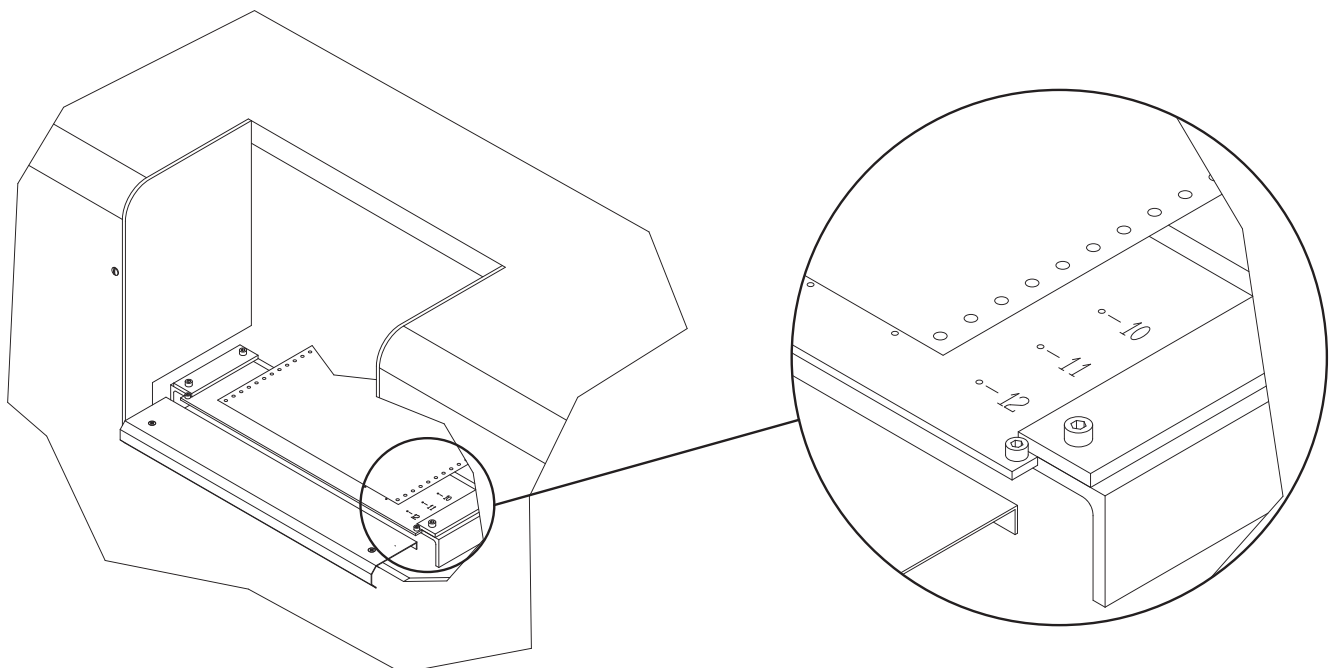



## 3.2 Operating panel functions

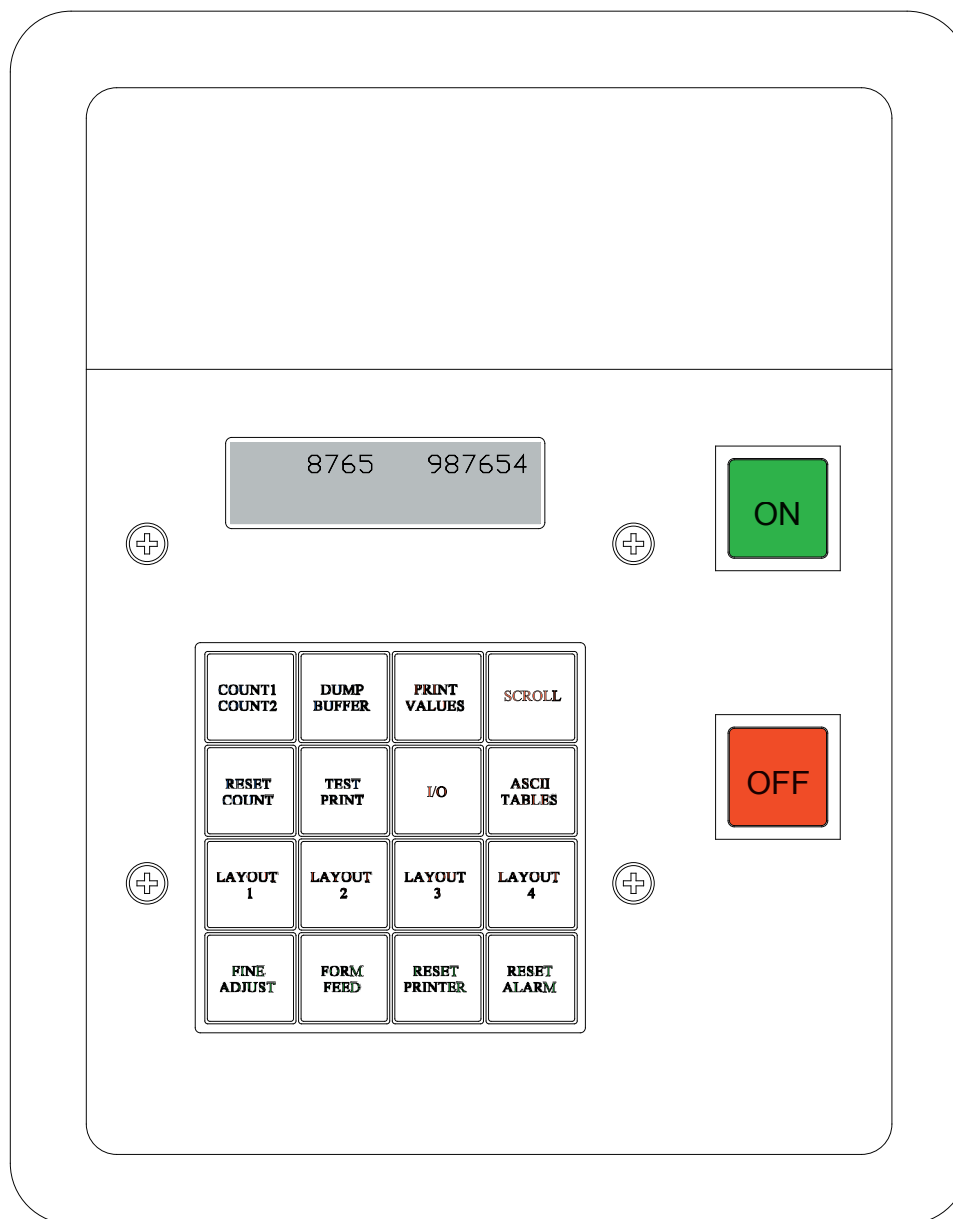

The green switch marked “ON” will turn the printer on, and the red switch marked “OFF” will turn the printer off.

There are three sheet counters. The one at the right-hand side of the display shows the total number of printed sheets and cannot be reset. The function can be compared with the total milage counter found on a car.

The remaining two counters - Count1 and Count2, are displayed one-at-a-time on the left-hand side of the display and can be reset. The function can be compared with the trip counter found on a car.

If a problem has occurred, an audio alarm will beep and a message in the display will show what has happened.

## Operating Panel functions

### COUNT1 / COUNT2

Selects which sheet (not pages!) counter that is viewed on the left hand side in the display. Selects between counter 1 and 2. When this button is in the outer (released) position, counter 1 is displayed, and when the button is in (depressed), counter 2 is displayed.

### DUMP BUFFER

During normal double sided printing, a volume of text of less than two pages will not be printed. This is because the printer is waiting for a full two page print job. By pushing DUMP BUFFER, the text remaining in the buffer will be printed.

### PRINT VALUES

Prints the current values of the LAYOUT, I/O and ASCII-TABLES.  
See chapter 3.3 "Print Values".

### SCROLL

Scrolls through the menus activated by:  
I/O, ASCII-TABLES, LAYOUT 1, LAYOUT 2, LAYOUT 3 or LAYOUT 4 buttons.

### RESET COUNT

Resets the sheet counter selected by COUNT1/COUNT2.

### TEST PRINT

This button has two functions: Test Print and Ready/Continue.

Test Print:

1st push down:

Prints a X-pattern on both sides of the sheet which shows each pin from each magnet rack printing on a separate line. Useful when searching for missing dots.

2nd push down:

Prints full cells and empty lines, together with the ASCII-table on both sides of the sheet. Useful for testing the printing pressure adjustments, and to see how the paper tolerates tightly grouped dots. (The paper might get a little "deformed" on this test).

3rd push down:

Prints full cells and empty lines, together with the ASCII-table single-sided. Useful for testing the printing pressure adjustments.

4th push down:

Prints a test pattern made of dot 1,3,5 and 2,4,6, single-sided. Useful when searching for extra dots.

5th push down:

As 1st push down etc.

Ready/Continue:

When the printer runs out of paper, the message PAPER OUT is shown on the display. Insert new paper, and push TEST PRINT in and out, and the printer will continue printing the last print job.

Do not use RESET PRINTER as this will clear the print job from the printer's memory!

**I/O - Input/Output**

Selects between serial and parallel port, and sets the data transmission values for the serial port.

1st push down: Displays which port is active.

To select serial or parallel port, the button must be depressed and then released. Now, while the display still shows the active port, press SCROLL to select the other port.

If the serial port is active, a 2nd push down will make it possible to use SCROLL to adjust the settings for the serial port.

**ASCII-TABLES**

This button has two functions:

It selects which 6 and 8 dot ASCII-table to be active for braille conversion and it displays the 6 and 8 dot ASCII-tables currently active.

1st push down:

Displays the active ASCII-table, number and country for the 6 dot mode.

2nd push down:

Displays the active ASCII-table, number and country for the 8 dot mode.



Note! This button will not change between the 6 and 8 dot print mode, it just displays which ASCII-tables that will be used in these modes.

To select from the 8 resident ASCII-tables in the printer, the following procedure should be used:

Push the ASCII-tables button, release it, then push it once again and hold. Now it is possible to change the active ASCII-tables with the SCROLL button. ASCII-table pair number one will be displayed first. (If there has been a pair of ASCII-tables loaded from the computer, these will be displayed first). If SCROLL is released, and pressed again, ASCII-table pair no. 2 will be displayed. This continues until pair no. 8 is reached, whereafter it will start at pair number one again.



Note! Scrolling through the resident ASCII-tables will clear any user table that has been downloaded from the computer. If this table is to be activated again, it must be downloaded from the computer again.

**Using the “LAYOUT” menu buttons.**

With help of the menu buttons (LAYOUT 1, LAYOUT 2, LAYOUT 3 and LAYOUT 4) the current values can be changed.

The first push of a menu button shows which setting is currently active - its current value.

If these settings are correct, wait a few seconds for the timeout to expire, or press the RESET PRINTER button and the setting will remain.

If you would like to change one of the settings, push the button several times, until the desired function is shown on the display, then hold it down. By using SCROLL, the complete menu for the function can be reviewed in the display. When the correct value is shown, release the button and either wait for the timeout, or use RESET PRINTER.



Note! The Current Values are saved in the battery-backup memory, and they will remain even if the power is turned off.

**LAYOUT 1**

Selects sheet length, line length or single/double -sided printing.  
Use SCROLL to choose each setting.

**LAYOUT 2**

Selects normal or Z-fold printing, if page 1 is to be up or down, and to choose between 6 and 8 dot braille.  
Use SCROLL to choose new settings.

**LAYOUT 3**

Selects the line spacing.

The line spacing is adjustable in steps from 0 to 16. In millimetres this will be from 0 to 5.08 mm. (One step equals 0.3175 mm). The setting 16 is the standard line spacing, 5.08 mm (0.2"). 8 is the setting for graphic, 2.54 mm (0.1"), and so on.

The function "Single or Double line spacing" will double the given line spacing. If, e.g. the current line spacing is 13 steps (4.1275 mm), selecting Double line spacing will increase it to 26 steps (8.255 mm).

Use SCROLL to choose new settings.

**LAYOUT 4**

Selects page adjust and page margin.



Note! Please keep in mind that there is a difference in the terms "page length" and "sheet length". By page length we mean the number of lines of text to be printed on a page, and by sheet length we mean the physical size of a sheet of paper in inches.

The number of lines which can be printed on a page, is dependent on whether 6 or 8 dot braille is used, the selected line spacing, and the page length settings.

The "Page Adjust" can have one of the following values:

NoFFed:

No form feed. This setting will cause the printer to print continuously. There are no pagebreaks, and it is possible to print an "infinity long sheet".

Max:

Maximum. This is the standard setting, and will give a maximum number of lines per page. How many lines that will fit on a page will depend on, e.g. the sheet length, if it's 6 or 8 dot braille, the line spacing and margins.

Max-1 to -9:

Maximum, -1 to -9. This setting will decrease the number of lines on each page with 1 to 9, (depending on the selected number). If, e.g. the maximum number of lines would be 29, and the setting "Max-4" is selected, the resulting number of lines will be 25.

On interpoint printing, this function will centre the text vertically on the page to keep the top and bottom margin approx. equal.

On single sided printing however, there will be no vertical adjustment and the empty lines will appear at the bottom margin.

The “Page Margin” function will adjust the page margin in steps from 0 to 20. The standard setting is 8, (8 = normal). The page margin will give different effect when used on single-sided, compared with double-sided. On double-sided printing, one step is equal to 0.6350 mm, and the text will be centred vertically on the page. If, e.g. a page margin on 6 steps is selected, the printer will print closer to the edges of the paper, and if a page margin on 20 steps is selected, it will give a larger page margin. This will affect both top and bottom margins, i.e. page margin.

On single-sided printing, however, the page margin will actually work as a top margin. (Note! The page lay out must be set to normal to be able to do the following). One step is equal to 0.6350 mm. It will “push” the text downwards the sheet. When the text reaches the bottom, (meaning that there will not be enough space on this page for the last line), this line will wrap over to the next page.

Use SCROLL to choose new settings.

### **FINE ADJUST**

Positioning the paper.

Each push down moves the paper forward a distance equal to 0.5”.

### **FORM FEED**

Advances the paper to the next sheet.

### **RESET PRINTER**

Resets the CPU unit and clears the buffer.

Must always be used if an error occurs (Printer Error in the display).

### **RESET ALARM**

For alarms, the audio alarm can be reset (e.g. Printer Alarm, Out of Paper).

For errors (Printer Error in the display), however, the RESET PRINTER must be used.

### 3.3 Print Values

This function gives a printout of the settings which is currently active in the printer; It also gives information about the 8 ASCII-tables in the printer.

When Print Values is used, the line length setting must be at least 36 characters. If not, this message will appear in the display:

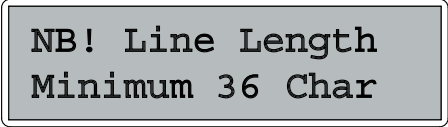

To be able to print the current values, change the line length to min. 36 characters.

Print Values might look like this:

```

BRAILLO NORWAY
VERSION 000.50 E
CURRENT VALUES

COMMUNICATION      = SERIAL
BAUD RATE          = 9600
PARITY              = NO
DATA BIT           = 8
STOP BIT           = 1

SHEET LENGTH       = 12
LINE LENGTH        = 42
PRINT              = DOUBLE

LAYOUT             = NORMAL
PAGE 1             = UP
DOT                = 6

LINE SPACING       = NORMAL
LINE SING/DOUB    = SINGLE

PAGE ADJUST        = MAX
PAGE MARGIN        = NORMAL

SHEET COUNTER 1   = 87654321

ASCII TABLE
NO 2 =      ENGLAND      6 DOT 044.00
          ENGLAND      8 DOT 044.00
    
```

“Sheet counter” shows the number of printed sheets (Not pages!). This is the same counter as on the right-hand side of the display. “ASCII table” shows which ASCII-table is active.

The remaining information in the Print Values printout tells which ASCII-tables are available in the EPROM, and might look like the list below.

BRILLO NORWAY

ASCII TABLES IN PROM

NO 1 =	DENMARK	6 DOT 045.00
	DENMARK	8 DOT 045.00
NO 2 =	ENGLAND	6 DOT 044.00
	ENGLAND	8 DOT 044.00
NO 3 =	GERMANY	6 DOT 049.03
	GERMANY	8 DOT 049.03
NO 4 =	GERMANY	6 DOT 049.04
	GERMANY	8 DOT 049.04
NO 5 =	ICELAND	6 DOT 354.00
	ICELAND	8 DOT 354.00
NO 6 =	ITALY	6 DOT 036.02
	ITALY	8 DOT 036.02
NO 7 =	NORWAY	6 DOT 047.03
	NORWAY	8 DOT 047.03
NO 8 =	SWEDEN	6 DOT 046.01
	SWEDEN	8 DOT 046.01

All the 8 tables are resident in the printer. The table which is active is shown under the “ASCII table” section of the printout. To select another table (among the 8), refer to chapter 3.2 “Operating panel functions”.

Note: This is just an example. The ASCII-tables listed will be dependent upon the combinations which are included in the printer. Some common combinations are listed below:

EURO 1 931203			EURO 2 931203			EURO 3 930106		
1	045.00	Denmark	1	032.00	Belgium	1	043.00	Austria
2	044.00	England	2	044.00	England	2	042.00	Czech/Slovakia
3	049.03	Germany	3	033.00	France	3	044.00	England
4	049.04	Germany	4	049.03	Germany	4	049.03	Germany
5	354.00	Island	5	049.04	Germany	5	049.04	Germany
6	039.02	Italy	6	039.02	Italy	6	030.00	Greece
7	047.03	Norway	7	047.03	Norway	7	036.00	Hungary
8	046.01	Sweden	8	041.00	Switzerland	8	047.03	Norway



AMERICA 931203			ASIA1 930118			ASIA2 941025		
1	055.00	Brazil	1	033.01	France	1	033.01	France
2	033.01	France	2	049.04	Germany	2	049.04	Germany
3	049.04	Germany	3	081.00	Japan	3	098.00	Iran
4	039.02	Italy	4	965.01	Kuwait	4	965.01	Kuwait
5	047.03	Norway	5	060.01	Malaysia	5	060.01	Malaysia
6	351.10	Portugal	6	047.03	Norway	6	047.03	Norway
7	034.00	Spain	7	966.00	Saudi Arabia	7	966.00	Saudi Arabia
8	001.00	USA	8	001.00	USA	8	001.00	USA

### 3.4 Messages/error messages

The text in the display can be divided into three groups; Messages, alarms and error messages. With messages, the printer operates normally. With some alarms, the printer can be operated to a certain degree, while other alarms are like error messages, in that the printer cannot be operated, and RESET PRINTER must be used.

The audio alarm (BEEP) is sounded for both alarms and error messages.

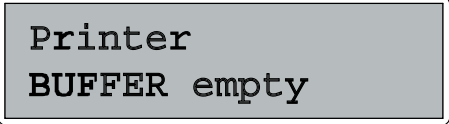
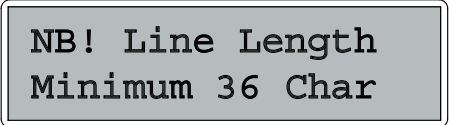
#### Messages:

1.  When “Dump buffer” is used, and the input buffer is empty, the message “BUFFER empty” is shown on the display. The printer is then ready to begin a new print job. Note: If there is text remaining in the buffer and “Dump Buffer” is not used, the text will appear at the beginning of the next print job.
  
2.  When PRINT VALUES is used, and the line length is set to less than 36 characters, this message will appear on the display. To print the current values, first set the line length to 36 characters or more.
  
3.  If there is detected one or more defect magnet(s) -when the printer is turned on, -when pressing reset, -or while the printer is running, this message will appear on the display. For more information - see chapter 3.6 “Selftest on magnets”.
  
4.  If there was detected some problems with the magnets during printing, and the problem is intermittent, this message will appear in the display. For more information - see chapter 3.6 “Selftest on magnets”.



**Alarms:**

1.

**Printer  
Out of Paper**

When the printer runs out of paper, the audio alarm is sounded, and the printer stops at the end of the next page. To continue printing, press RESET ALARM and then TEST PRINT after the new paper has been inserted. For information, see TEST PRINT - Ready/Continue, in chapter 3.2 “Operating panel functions”.

If the alarm is sounded when there still is paper in the machine, this may have been caused by one of the following:

- A. Paper dust in the paper out sensor.
- B. The paper guide which the paper out sensor is attached to might be bent or damaged, so the distance from the sensor to the paper is too big to detect the paper.
- C. The sensor is not connected.
- D. Defect sensor.

If one of these problems occurs, clean the sensor, make sure that it's connected to the motherboard, and check that the sensor is not more than 4 mm from the paper surface.

The following alarms are usually caused by a problem with the handshake in the data communication between the computer and the printer. It will be necessary to press RESET printer after these.

The text which remains in the buffer during these alarms can be printed by using DUMP BUFFER.

However, during these alarms one must check the transmission parameters for both the printer and the computer, and also possibly the software in use. If any changes are made on the printer, one will have to RESET PRINTER to register these changes.

2.

**Printer  
Buffer Overflow**

This alarm indicates that the computer has not registered that the input buffer in the printer is full, and continues to send data which causes the buffer to overflow.

The text which remains in the buffer can be printed by using DUMP BUFFER.

If this alarm occurs, check the transmission parameters for both the printer and the computer, and also possibly the software in use.

3.

**Printer Alarm  
Overrun/Framing**

Error in at least one of the following transmission parameters: Baud rate, no. of data bits and / or no. of stop bits. If this alarm occurs, check the transmission parameters for both the printer and the computer, and also possibly the software in use.

4. **Printer Alarm  
Parity** Error in the parity check in serial communication. If this alarm occurs, check the transmission parameters for both the printer and the computer, and also possibly the software in use.
5. **Printer Alarm  
ESC-Sequences** Some irregularities have been detected when receiving escape-sequences. If this alarm occurs, check the transmission parameters for both the printer and the computer, and also possibly the software in use. If the escape-sequences are sent by a batch-file or are integrated in the text-file, be sure that the correct ASCII-value combinations are used.

On error messages, the printer cannot be operated, and RESET PRINTER must be used.

1. **Printer Error  
General Failure** If the main motor starts, but for some reason stops, this message appears in the display, together with the audio alarm. The reason might be:
- A. Bad connection in the motor wires or a problem inside the electrical unit (frequency converter).
  - B. The belt on the printer breaks during printing. Check the belt, and replace if needed.
  - C. The main sensor might be defect, or have loose connector.
2. **Printer Error  
Start Motor** If the main motor does not start, this error message is shown in the display. The reason might be:
- A. The main motor is not connected. Check that the cable to the motor is connected.
  - B. The belt is broken or out of place.
  - C. Defect frequency converter.
  - D. System error.
- However, if the main motor does start, but this message is still appearing in the display, it could be caused by a defect main sensor, or a loose connector on the main sensor.
3. **Printer Error  
Stop Motor** The main motor does not stop. The reason might be:
- A. Defect electrical unit.
  - B. System error.

4.

**Printer Error  
Paper Feed**

Disagreement between the paper feed assembly (the paper) and the program system.

The reason might be:

- A. The paper is stuck, and the paper feed motor has slipped. Free the paper jam, push RESET PRINTER.
- B. The sensors on the paper feed might be defect, or have loose connectors.
- C. System error.

### 3.5 Test Print

The test print program is designed to ensure that the 168 printing mechanisms functions properly.

This printer will do a electrical test on all of it's printing mechanisms continuously during printing. However, this electrical test will not tell if something is wrong mechanically, and therefore it is recommended to print a few pages of test print before beginning the day's production. By doing so, it's quite easy to see if all printing mechanisms are functioning mechanically.

This printer has both single-sided and double-sided (interpoint) test print patterns. See also TEST PRINT in chapter 3.2 "Operating panel functions".

The test print consists of four different patterns. A X-pattern, some full cell lines, empty cell lines, the complete ASCII-table and a pattern consisting of a character with dot 1,3,5 combined with a character with dot 2,4,6.

How to use the test print:

The test print button on the operating panel is used to start and to switch between the different test patterns. To switch to the next test pattern, you must release the button, wait for the paper to stop moving, and then press the button again. When you have reached test pattern number four, it will start on number one again.

If you do not release the test print button, the printer will continue to run the test pattern without stopping. This can be useful for troubleshooting.

If you do release the test print button, the printer will continue printing until the paper is positioned correctly for the next print job.

- 1st test pattern:

Prints an "X"-pattern on both sides of the sheet which shows each pin from each magnet rack printing on a separate line. Useful when searching for missing dots.

- 2nd test pattern:

Prints full cells and empty lines, together with the ASCII-table on both sides of the sheet. Useful for testing the printing pressure adjustments, and to see how the paper can take heavy printing.

- 3rd test pattern:

Prints full cells and empty lines, together with the ASCII-table single-sided. Useful for testing the printing pressure adjustments. To get the single-sided test print to alternate between the sides of the sheet, LAYOUT 2 must be set to Z-fold.

- 4th test pattern:

Prints a test pattern made of dot 1,3,5 and 2,4,6, single-sided. Useful when searching for extra dots. To get the single-sided test print to alternate between the sides of the sheet, LAYOUT 2 must be set to Z-fold.

The chapter 4.1 "Printing principle" illustrates how the printing mechanisms are placed.

Instruction for troubleshooting will be illustrated by examples in chapter 4.2 "Troubleshooting".

### 3.6 Self-test on magnets.

This printer has 168 electrically activated magnets. Because of the tremendous workload and their sensitive nature, these magnets may fail sometimes. It is difficult to see if a column of dots suddenly is missing. Because of this there is integrated a self-diagnostic system that check the magnets continuously during printing.

The system checks the magnets by measuring the internal resistance in the coil.

The system will behave a little different if a defective magnet is detected, on power-on/reset or during printing.

Please observe that the numbering of the magnets in a magnet rack, always starts at “one” at the end where the connections are. (It does not refer to dot number, character number or column number!).

#### On power-on or reset:

If a magnet is defective when the power is turned on (or reset), the printer will give an audio alarm, and all the magnets will start to go on and off at a certain frequency. The frequency will vary depending on the number of defect magnets. (Slower frequency for more problems).

To be able to run the printer with a defective magnet(s), you can bypass the magnet-test by pressing the “Fine adjust” button on the control panel.

The display will indicate where the problem is located (what magnet rack), how many defective magnets, and position of the magnet(s) on that rack. See the example:

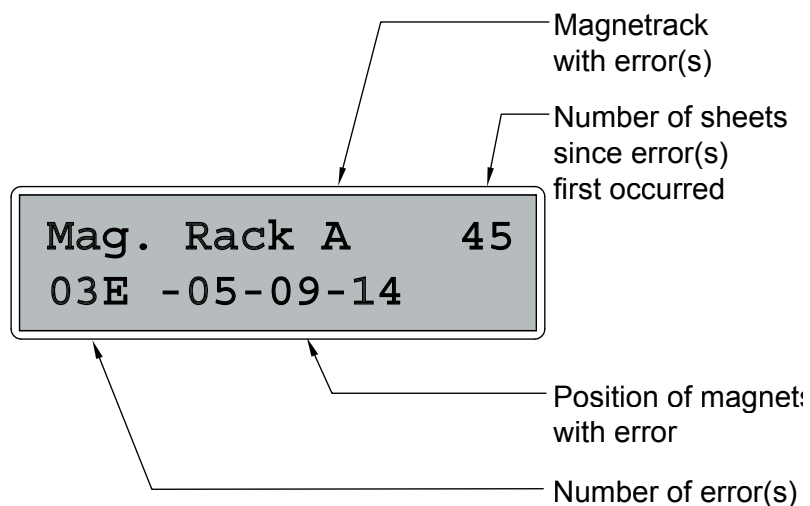

**During printing:**

If a defective magnet is detected during printing, the printer will not stop. Instead it will give an audio alarm, and display a message like the one in the example below.

You can also see from the way the information is displayed, if this magnet is constantly defective, or if the problem is intermittent. There will be information in the bottom line in the display as long as the problem is present.

The sheet counter will show how many sheets that have been printed since the problem first occurred.

If the problem disappears, the information on the bottom line will also disappear.

**Constant defect magnet:**

When the magnet(s) is constant defective, the display will indicate where the problem is located, the number of sheets since the problem first occurred, how many defective magnets, and the exact position of the magnet in the magnet rack.

When the printer stops, the information in the display will remain until you press “Reset printer”. If the defective magnet has not been replaced, the printer will proceed as described in the “On power-on or reset” section.

**Intermittent problem:**

The bottom line in the display will only be displayed as long as the problem is present. If the problem disappears, the information on the bottom line also disappears.

See the figure below:

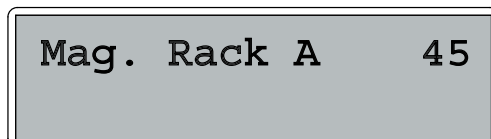

Mag. Rack A      45

However, the printer will still remember where the problem was, and the information can be displayed after the printer has stopped. Do not use “Reset printer”, this will clear the information from the printers memory! Stop the printer by stopping the text sent from the computer and wait for it to finish. When the printer stops, the display will not show the bottom line, but by pressing the “Fine Adjust” button on the control panel, the information will appear on the bottom line in the display.

## 4. SERVICE AND MAINTENANCE

When doing service or maintenance, the cover must be taken off. Some procedures covered in this chapter might be done simply by removing for example a side panel. But we recommend for “bigger operations” to remove the cover completely. Please see chapter 2.2 “Removal of cover” on how to do this.

When the cover is removed, the operator panel is also removed. To be able to run tests and so on, you can place the cover beside the printer so that you are able to connect the cables to the operator panel. Or you can unscrew the panel from the cover and keep it nearby the printer.

Please observe that the operator panel is an electrical board, and **MUST NEVER BE LAYED ON A CONDUCTIVE SURFACE!** If there is a short circuit on the board, it might damage the board.

For an explanation regarding how to turn this printer on without having the cover on, please see chapter 2.6 “Turn on the printer”

### 4.1 Printing principle

The figure below is a very simplified version of the printing mechanisms in this printer.

The four “bars” across the paper indicates the magnet racks.

The magnet racks are named from A to D.

Magnet rack A and B make dots on the side of the paper facing down, and magnet rack C and D makes the dots on the side facing up.

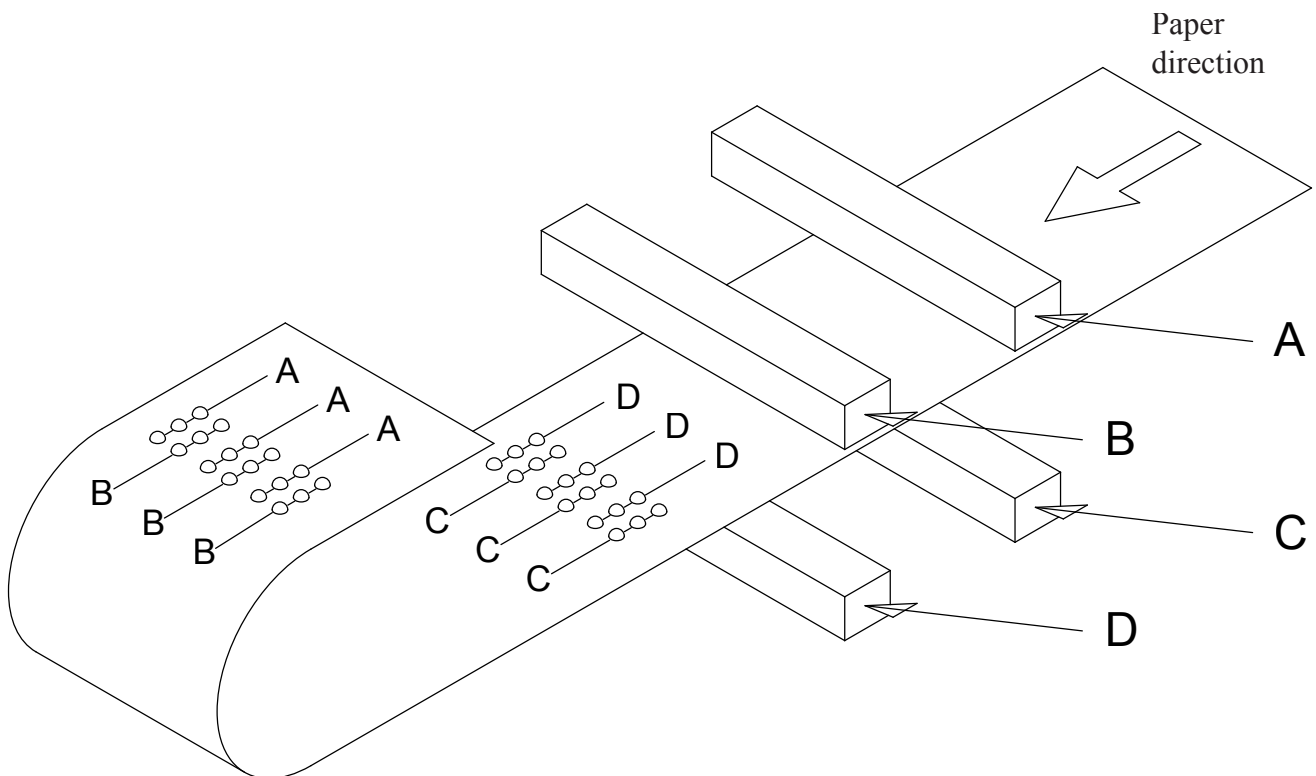

The crossection below is a “theoretical” figure showing the parts inside the printing mechanism. The printer has been “sliced” to show more detailed of how it is constructed.

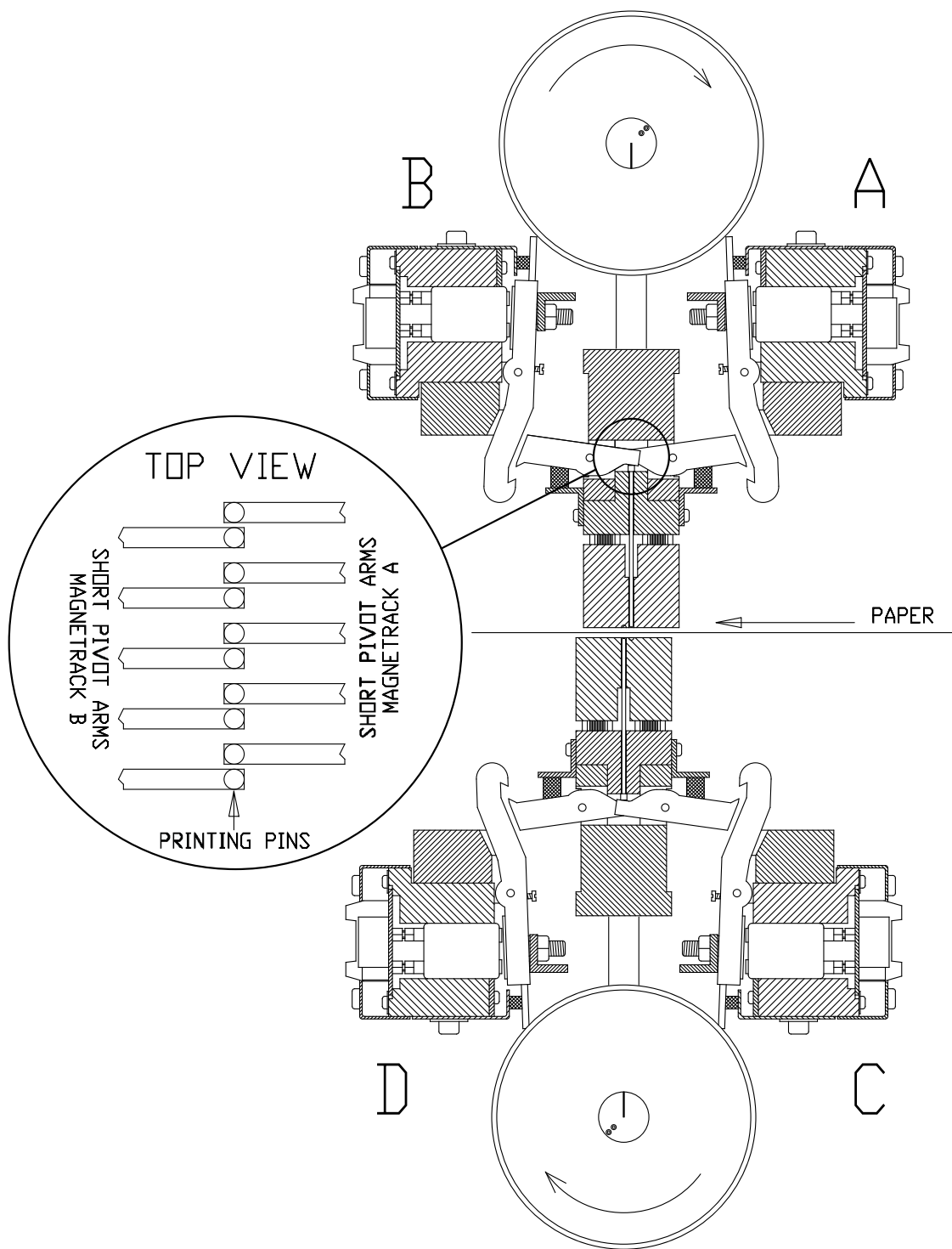



Please see the figure on the previous page.

The two shafts, one at the top and one at the bottom, are rotating synchronized. On each shaft there are eccentrics that are pushing the beams and papershoes up and down. This movement is used both to hold the paper and to make the dots. A row of dots is printed for each revolution of the shafts. The shafts must rotate three times to form a complete row of characters.

Please see figure below:

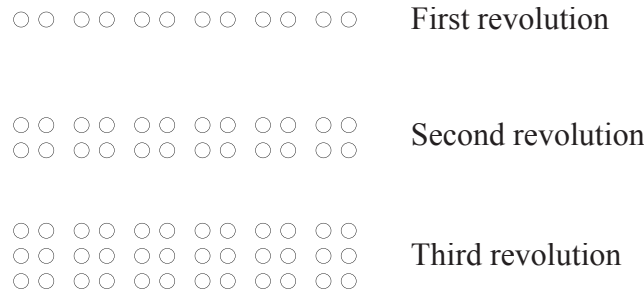

To be able to print interpoint (where both sides of paper are printed simultaneously), the back page is offset a little to the right and a little down to fit in between the dots on the front page.

Please see figure below:

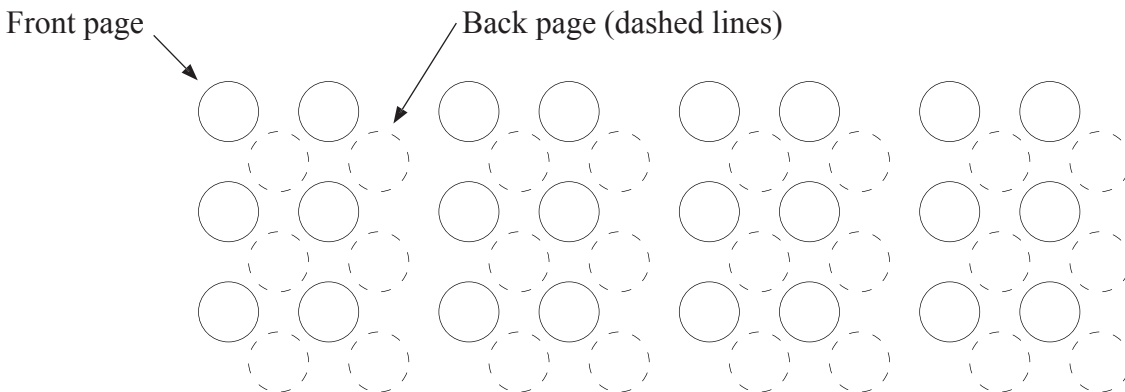

Dimensions on 6 and 8 dot braille cell, all numbers in mm.

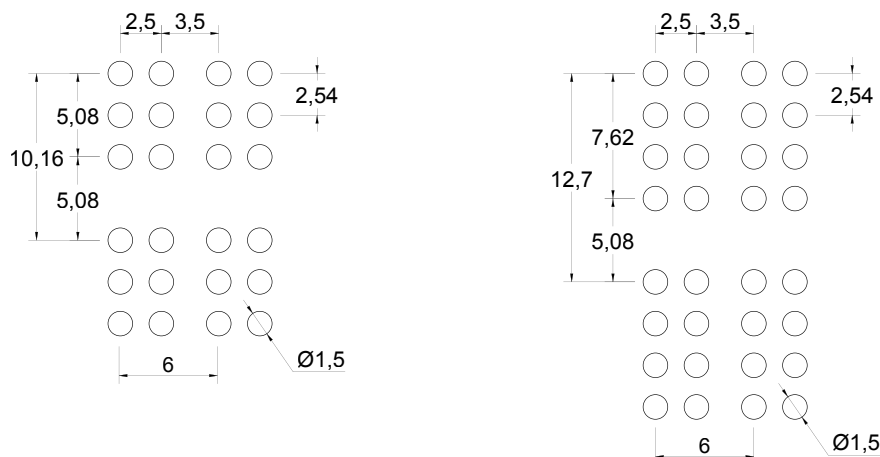

The drawing on this page is to help to understand the basic principle of how the dots are printed. Please also see the drawings on the next page.

The parts in the upper left of this drawing is one of the magnet racks. The parts in the lower right, are the beam and paper shoes. The magnet racks do not move, but the beams and the papershoes are moving up and down for every revolution of the eccentric shafts.

Inside each magnet rack there are 42 electrical magnets. The magnets are controlling the long pivotarms.

When a dot is going to be printed, the magnet is engaged, and the long pivot arm will be drawn against the magnet poles.

At the same time, the beam and the papershoe will start to move downwards, and the short pivot arm will catch the hook of the long pivot arm. The beam will continue to travel downwards, and will force the printing pin into the paper.

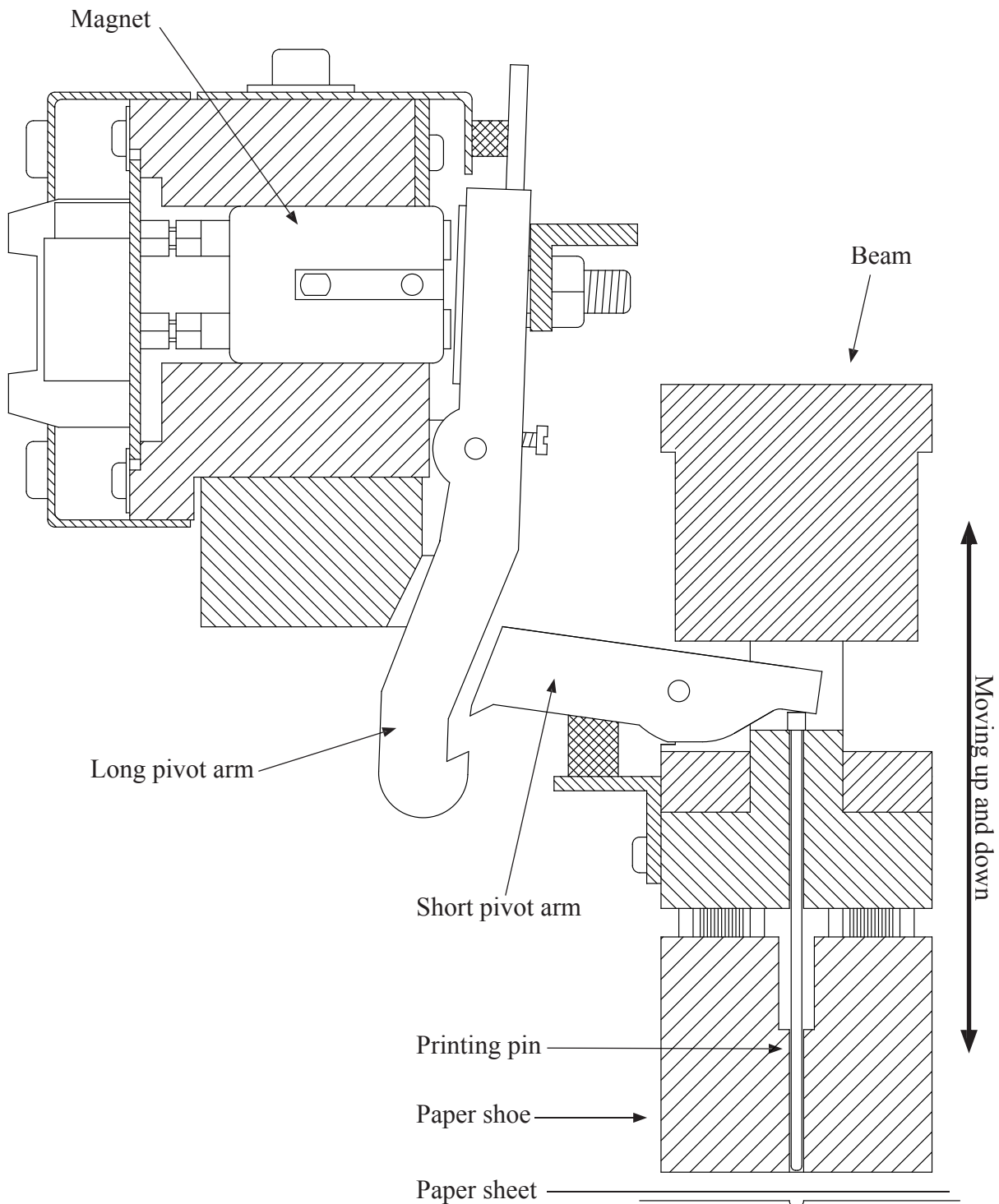

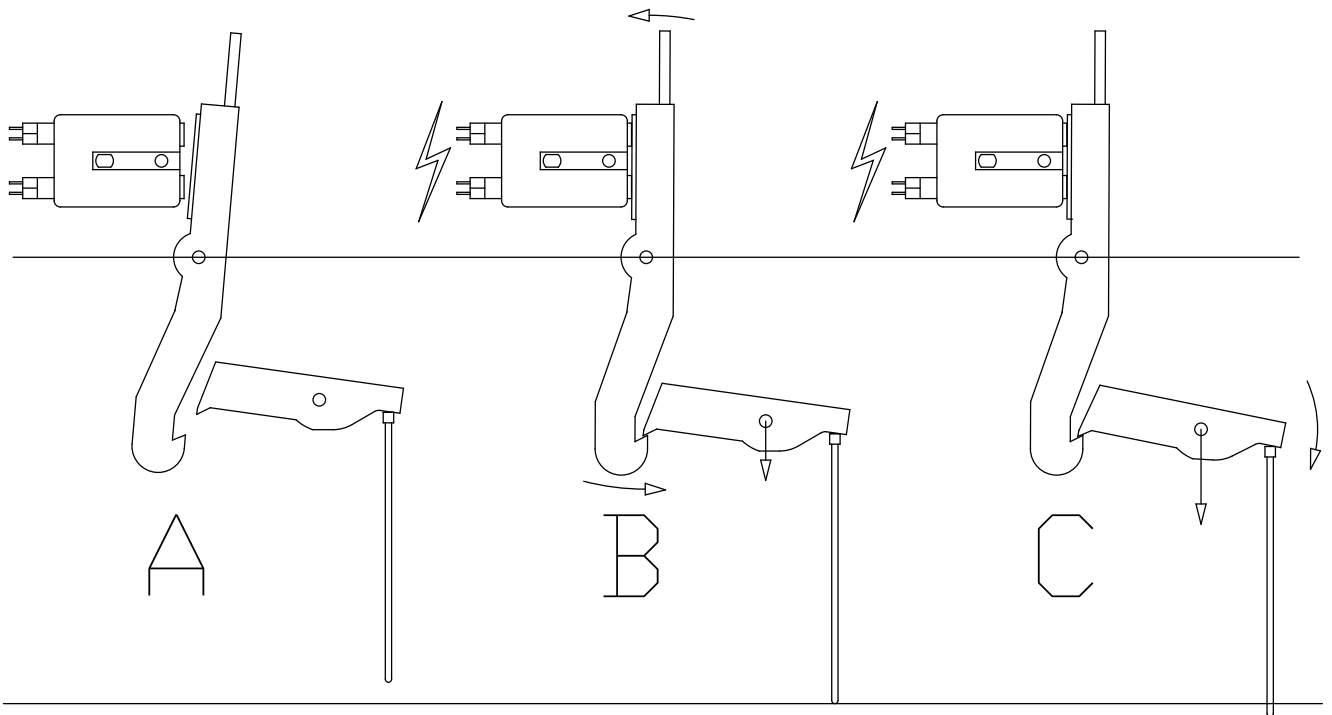
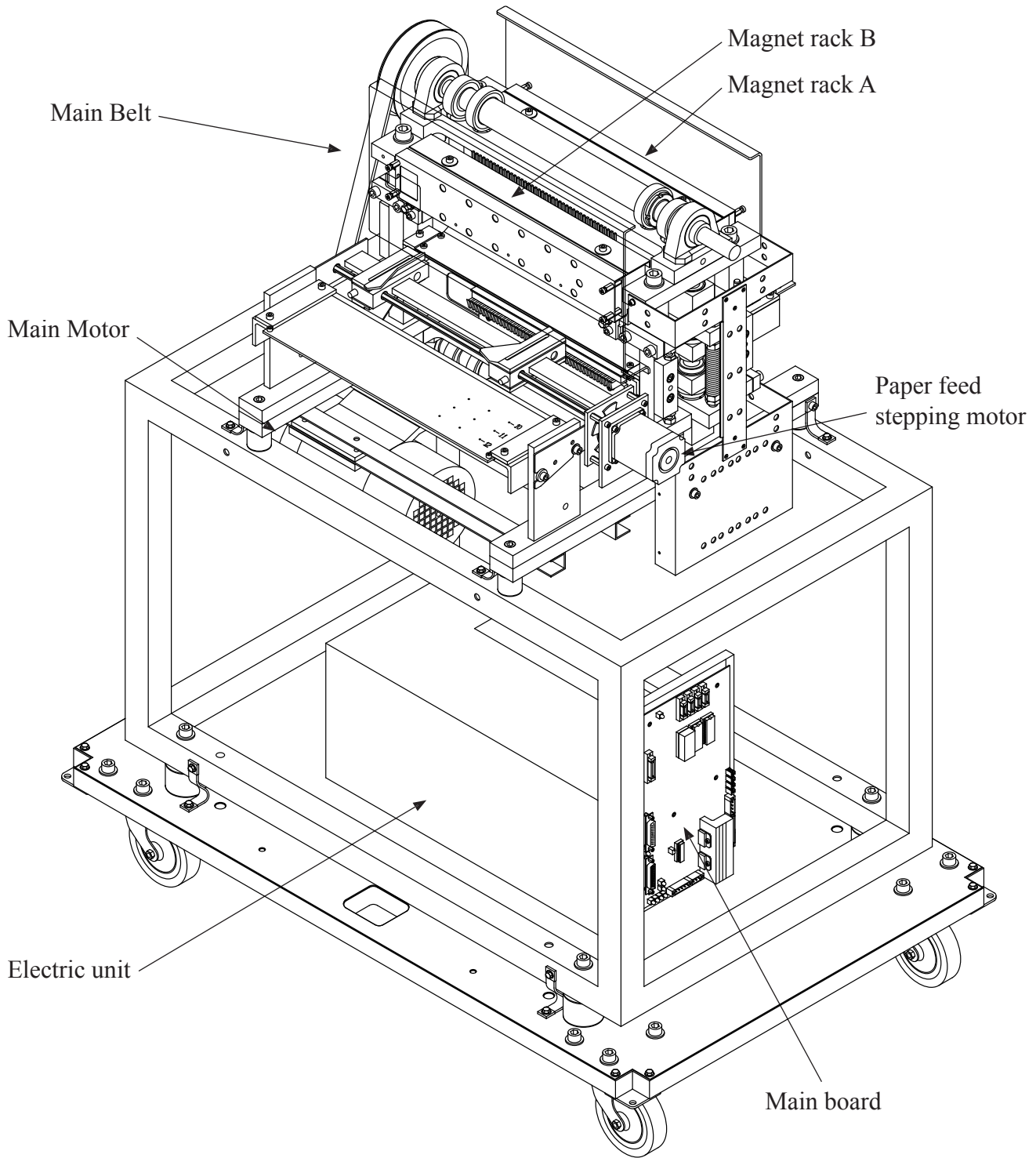

**Figure A**  
Shows the position on the pivot arm when the printer is not printing, and the magnet is not engaged.

**Figure B**  
Now the magnet is engaged, and the long pivot arm has been drawn against the magnet. The short pivot arm is moving down towards the hook on the long pivot arm.

**Figure C**  
The long pivot arm's hook catches the short pivot arm. When the short pivot arm moves further down, the printing pin will be forced down into the paper and make a dot.

### General overview



## 4.2 Troubleshooting, incorrect braille.

Lets say that through proofreading, errors have been found in some of the characters in the printed text. The first thing to do is:

Check the characters in the text-file in your computer to find out if the error could come from the text-file and not from the printer.

If your text-file is OK, the problem is caused by the printer.

On earlier models of Braillo printers, this could be caused by either a electrical problem or a mechanical problem. But on this model of printer, there is integrated a self-diagnostic system that is checking the magnets continuously during printing, and this will trigger an alarm if it detects some electrical problems with the magnets. So, the missing dots found here are probably caused by some faulty mechanical parts or it could be dirt clogging the moving mechanisms.

Inside the printer there are four identical magnet racks, named from A to D. Each magnet rack contains 42 printing mechanisms. There are totally 168 printing mechanisms to choose from when the error search begins. See chapter 4.1, "Printing principle".

If the printer has been printing a lot (a lot could be either a year, or it could be 1000 printing hours, depending on what comes first) when this happens, it could be that the printer just needs regular maintenance. See chapter 4.6 "Magnet rack, cleaning", and chapter 4.20 "Maintenance".

As a start, you should run the built-in Test Print. Depending on what kind of errors you have, you should use different tests.

The essential thing at this stage is to find which magnet rack(s) is causing the trouble.

If there is missing dot(s), use the X-pattern to detect which magnet rack(s) is missing the dot(s).

If there are too many dots, use the full cell lines, or the test pattern on test print no. 4, and the extra dot(s) will appear in the space between the lines.

However, the best test is ordinary text, if a proofreader is available. To locate the faulty magnet rack(s), see figures in chapter 4.1 "Printing principle".

There are several methods to make experiments to confirm that you have found the correct magnet rack(s). One good method is to disconnect the rest of the magnet racks, and see if the printer still have problems.

To determine if a problem is electrical or mechanical.

See if the suspected pivot arm is moving like the rest of the pivot arms on the magnet rack. If it does move, but still does not make dots, then it is probably a mechanical problem. If it does not move and it is possible to pull the suspected long pivot arm with your finger during embossing and the dots appear. Then it most likely is caused by some problems in the electric circuits.

If one magnet rack is missing all the dots all the time, it could be because of a blown fuse. On the back of the magnet racks there is a red lighth that is indicating that the magnet rack has power. If this lighth is dark, check the fuse for the magnet rack.

See chapter 6.2 "Electric unit overview" for more details.

Possible reasons for errors:

See figures on the next page.

If a dot from a certain printing pin is missing regularly, the reason might be one of the following:

1. Defective magnet (The self-diagnostic system will find this one first).
2. Broken short pivot arm.
3. The long pivot arm cannot move because of dirt.
4. The printing pin is stuck because of dirt, causing the short pivot arm to miss the long pivot arm.
5. Errors in the magnet rack board.

If dots from several printing pins are missing now and then, the reason might be one of the following:

1. The sponge list is pushing too hard on the long pivot arm.
2. The gap between the two pivot arms are too large.
3. The support list has become sticky on the side against the long pivot arms, and the long pivot arm does not move properly.
4. The sponge list on the short pivot arm is so worn/compressed so that it will not give enough tension on the pivot arm.

If there are too many dots on the paper, the reason might be one of the following:

1. The sponge list is not pressing enough against the long pivot arm.
2. The gap between the two pivot arms are too small.
3. The magnet poles have become sticky, and this causes the pivot arms to stick to the magnet.
4. The long pivot arm (3) does not move properly.

Control:

To be sure that you have found the right mechanism after the troubleshooting, you can do the following test: Carefully pull the suspected long pivot arm against the magnet with your finger.

Note! Please be careful to avoid all other moving parts with you hair, clothes and the rest of your body!

At the same time, run a test print. The mechanism with the finger on, will make a column of dots downwards the sheet until you take the finger away. By doing this you can see if this column of dots is situated on the same place (and same side!) on the sheet as the error is.

Observe that the same printing mechanism (magnet, long pivot arm, short pivot arm and printing pin) makes all the dots in a column downwards the page.

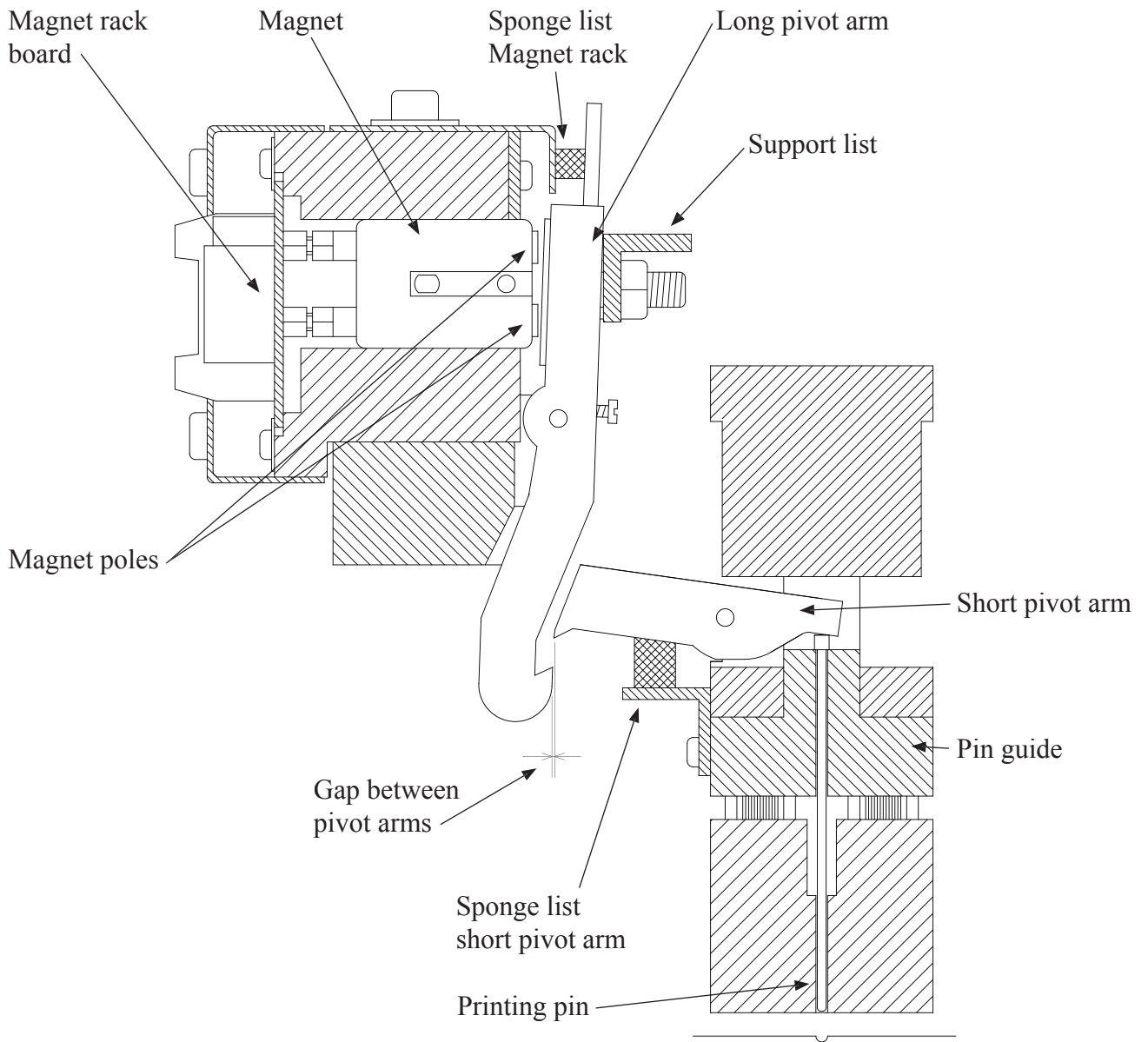

### 4.3 Magnet rack, removal

Please see figures below:

Disconnect the cables for the magnet rack.  
Remove the magnet rack by unscrewing the four screws shown in the figure.  
Magnet racks A, B and C are quite easy to reach, but to remove magnet rack D, it is often best to first remove the paper feed tractor.

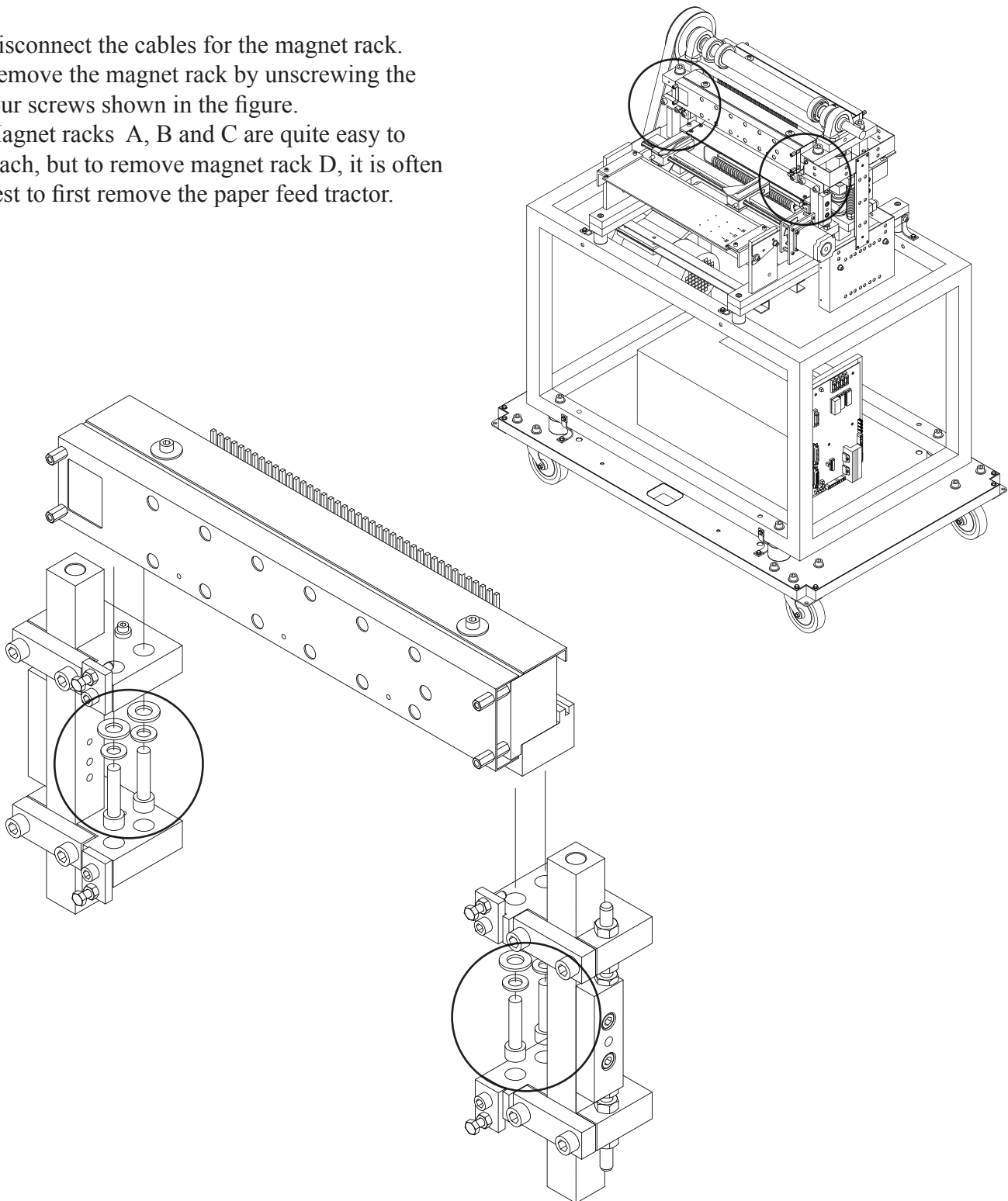



#### 4.4 Magnet rack, disassembly, step by step.

There are two main reasons for disassembling the magnet rack. It could be to replace some parts, i.e. a defect magnet, a worn pivot arm, or it could be for regular maintenance.

The magnet racks can be considered as the parts of the printer that will have the greatest influence on the dot quality, so it is very important to know how to deal with them.

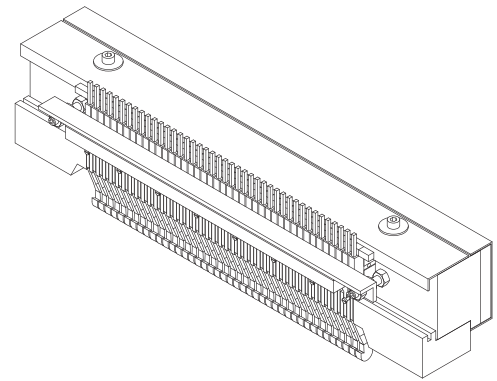

Take the magnet rack out of the printer like described in chapter 4.3 “Magnet rack, removal”. Next, follow the instructions below.

---

**Step 1.** Remove the two bolts holding the spongelist, and then remove the spongelist.

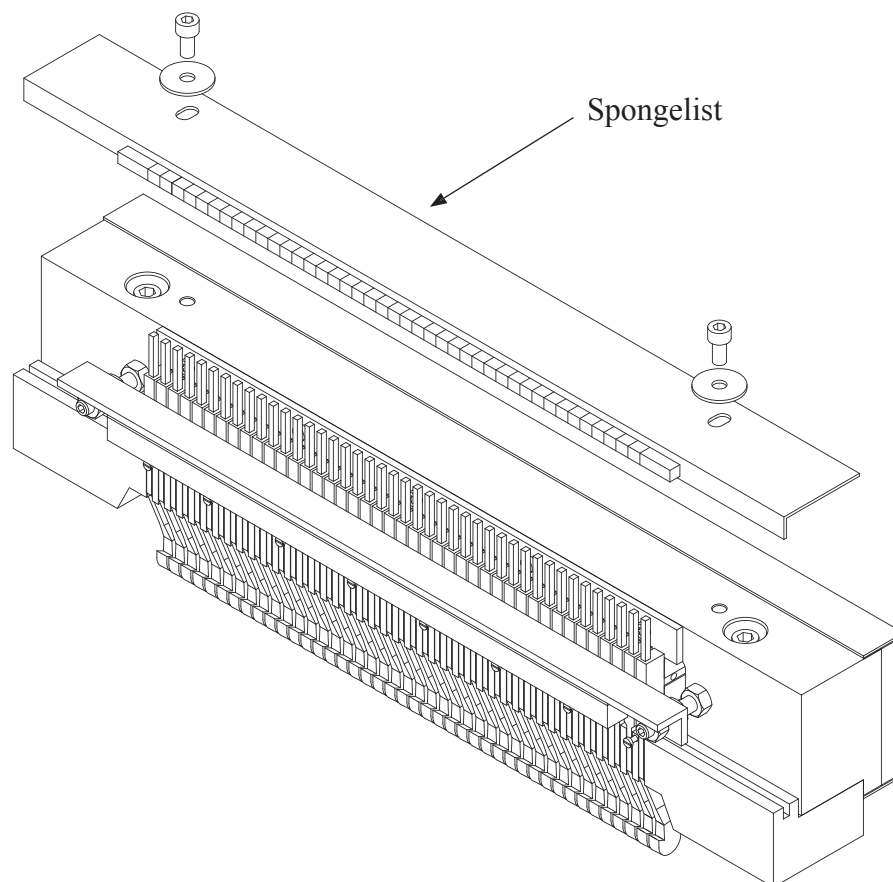

**Step 2.** Remove the two nuts holding the supportlist, and then remove the supportlist.

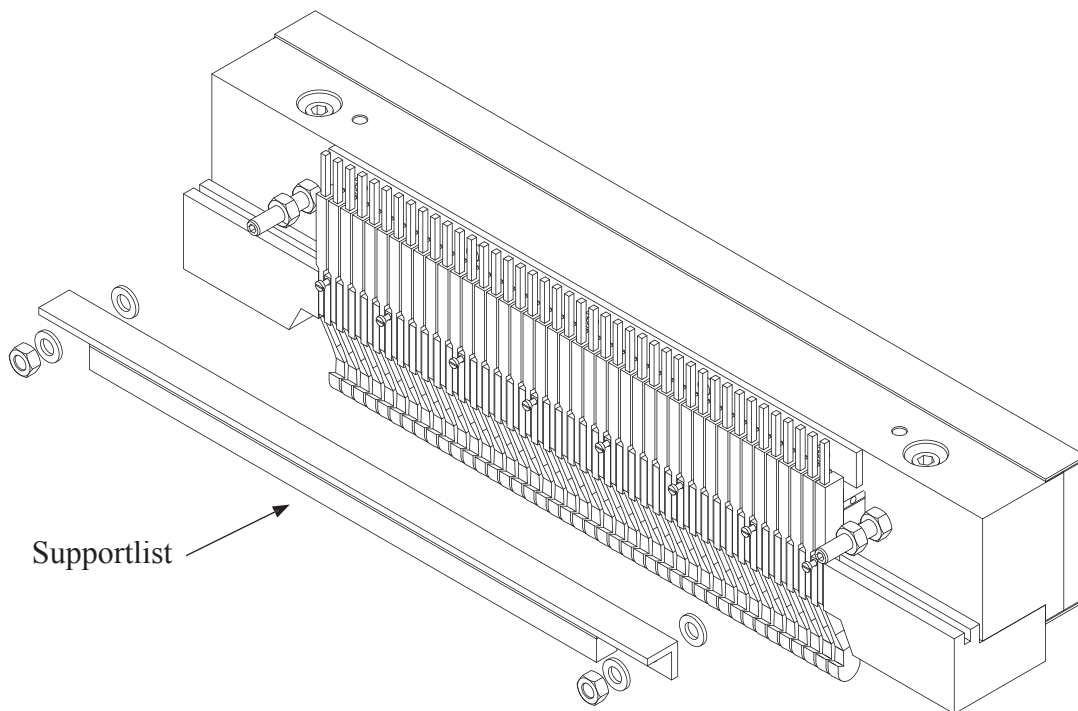

**Step 3.**

Remove the two bolts holding the pivotarm fastener, and then carefully remove the pivotarm fastener. The magnetrack is now disassembled.

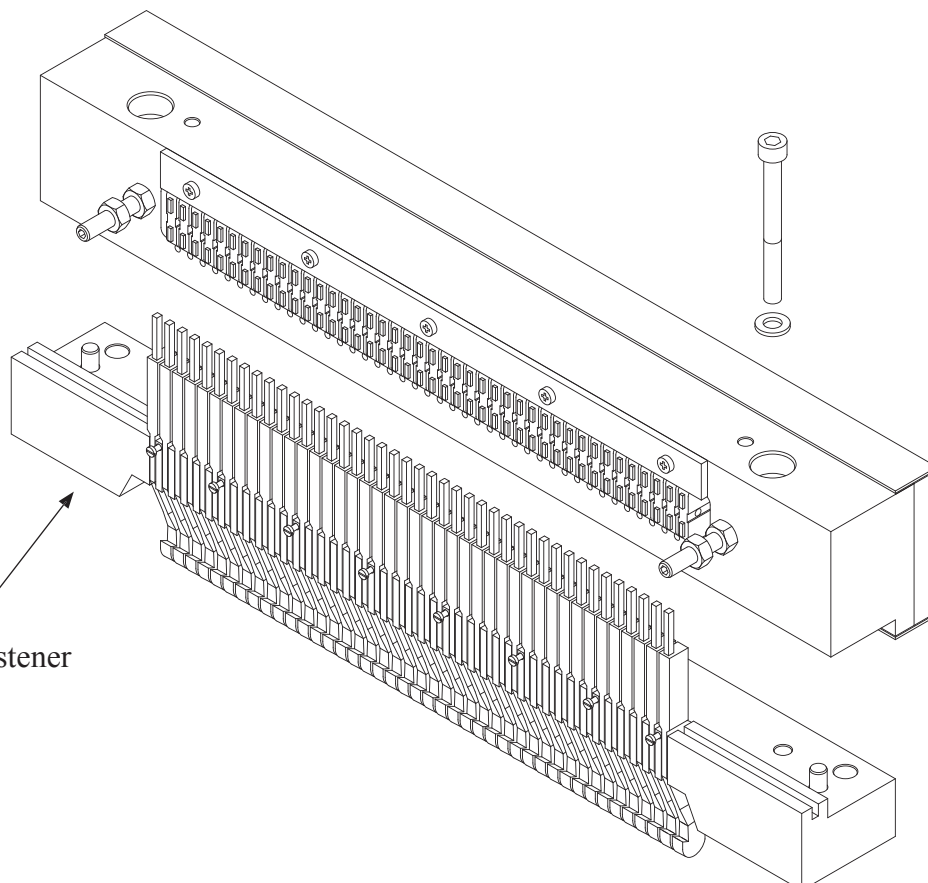

## 4.5 Magnet, replacement

Please observe that the numbering on the magnets in a magnet rack, always starts at “one” at the end where the connections are. (It does not refer to dot number, character number or column number!).

Disassemble the magnetrack like described in chapter 4.4 “Magnet rack, disassembly, step by step”. Next, follow the instructions below.

---

**Step 1.** Remove the five screws holding the list, and the list.

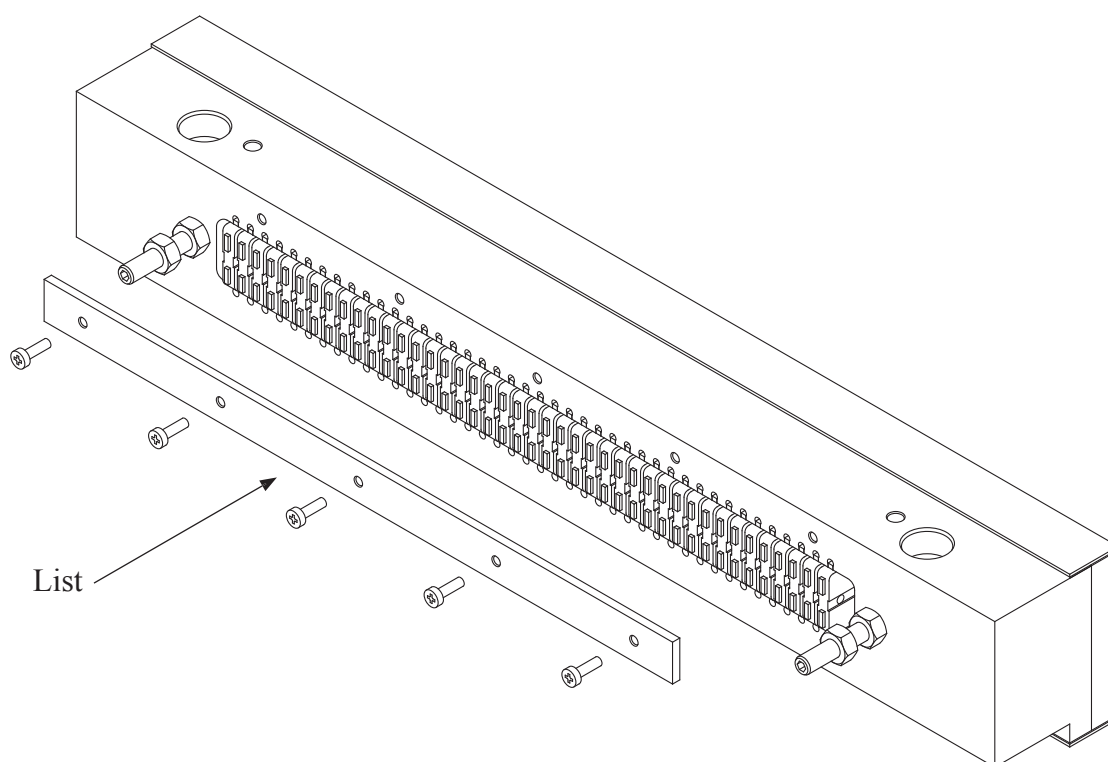

**Step 2.** Pull out the defect magnet with, e.g. a narrow pair of “needle nose” pliers.

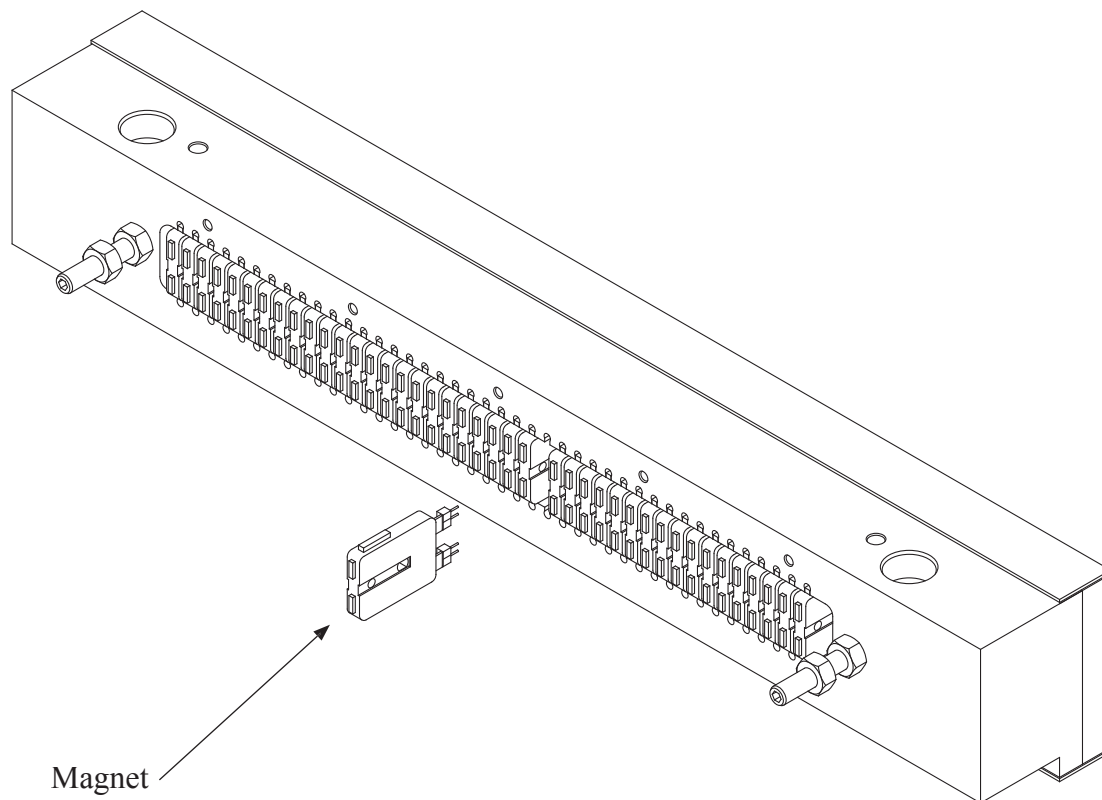

**Step 3.** Check the magnets internal resistance if you have an ohm-meter available. The resistance should be from 185 ohm up to 240 ohm. Any value outside this range indicates a defective magnet.

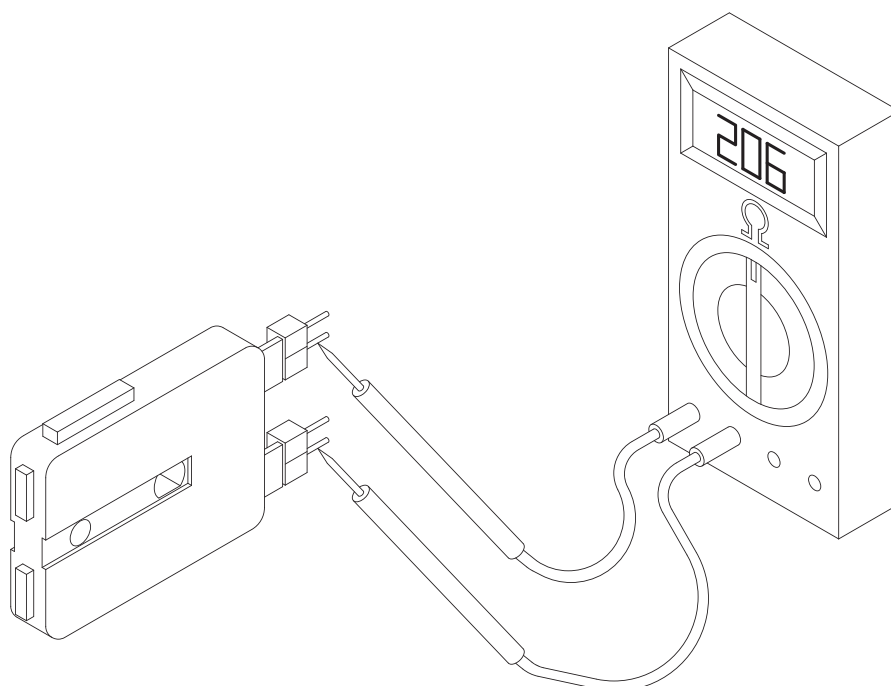

**Step 4.** Replace the defective magnet with a new magnet in its place. Note: The spikes on one of the sides on the magnet. These spikes must be oriented the same direction as the rest of the magnet's spikes in the magnet rack.

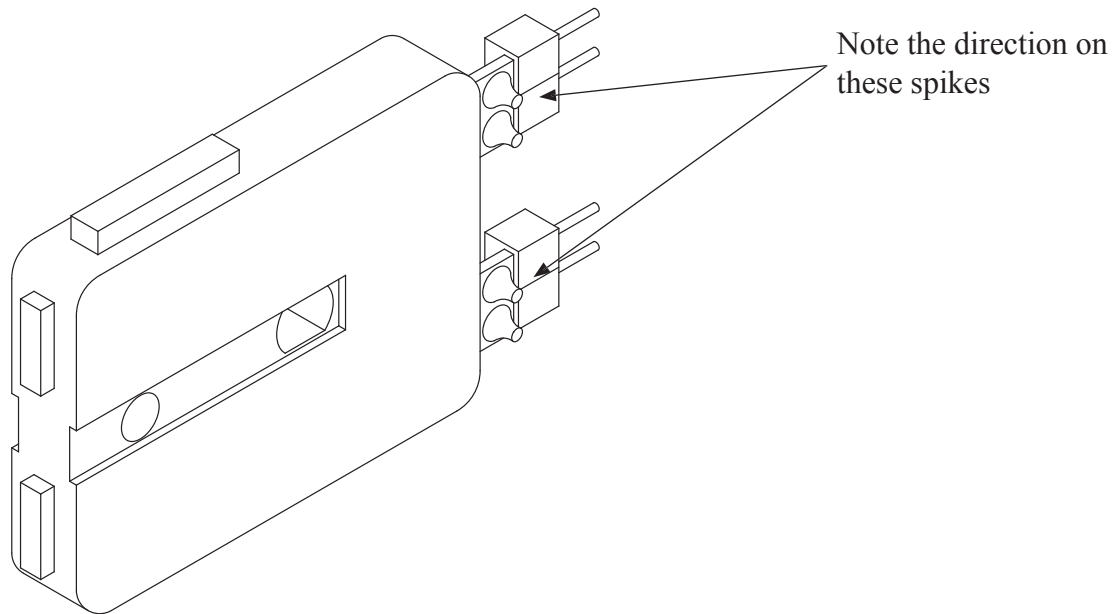

### 4.6 Magnet rack, cleaning

Remove the magnet rack as described in chapter 4.3 “Magnet rack, removal”. Then disassemble the magnet rack as described in chapter 4.4 “Magnet rack, disassembly, step by step”.

Now use a damp cloth moistened with cleaning alcohol to wipe off the surfaces as described in the figure below:



Note! Do not ever oil, grease or lubricate any of the moving parts on a magnet rack! This will only attract paper dust.

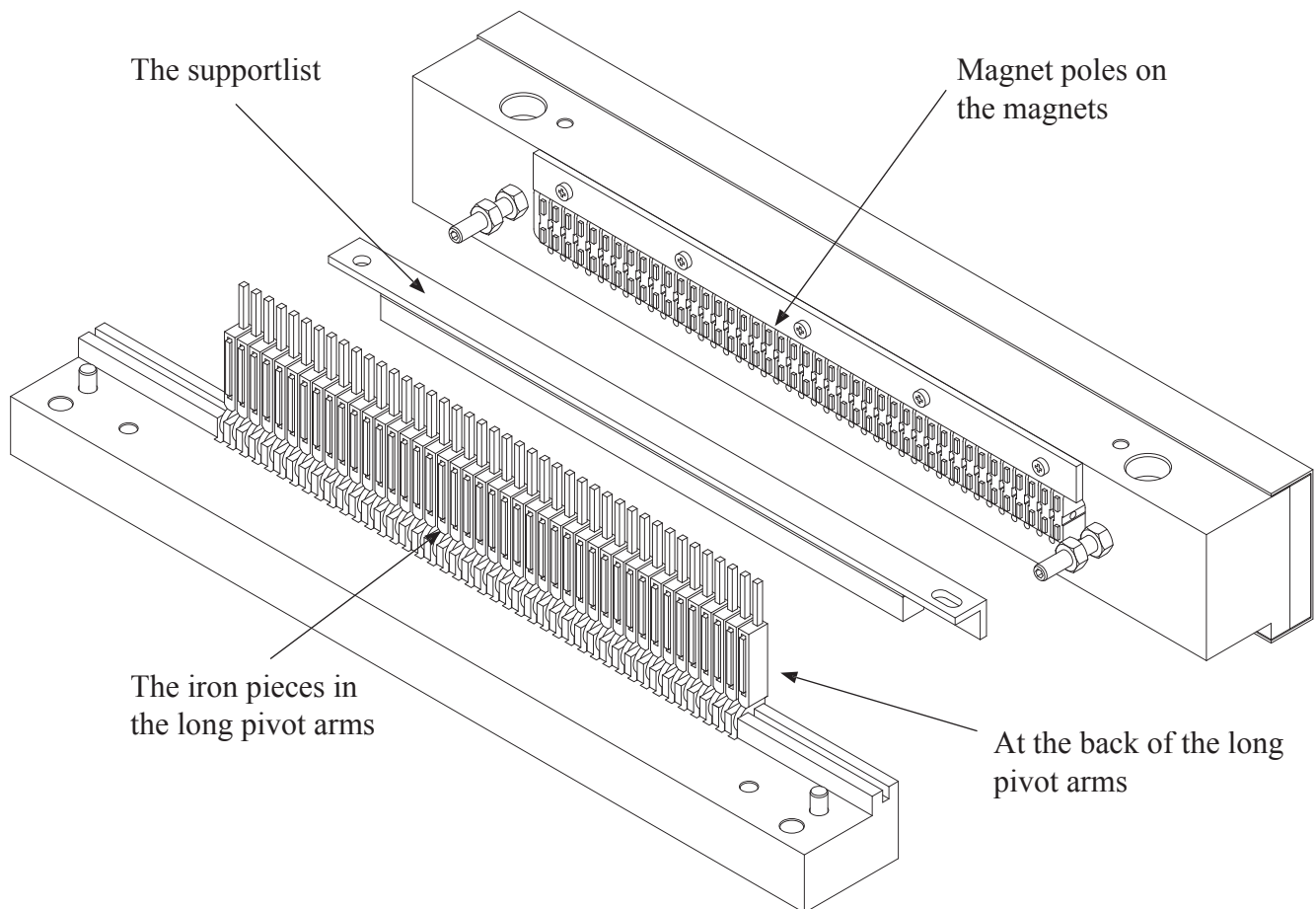

## 4.7 Magnet Rack, adjustment

Before replacing the magnet rack in the printer, two adjustments must be checked.

The first one is the distance between the support list and the pivot arms. This is the travelling distance for the pivotarm. And it should be adjusted to about 0.8 mm using a feeler gauge. Adjust the nuts on both ends of the magnet rack.

If the 0.8 mm feeler gauge goes in, and the 0.9 mm feeler gauge does not, consider the adjustment OK.

Make sure that the nuts are thight when you are done!

Please see figure below:

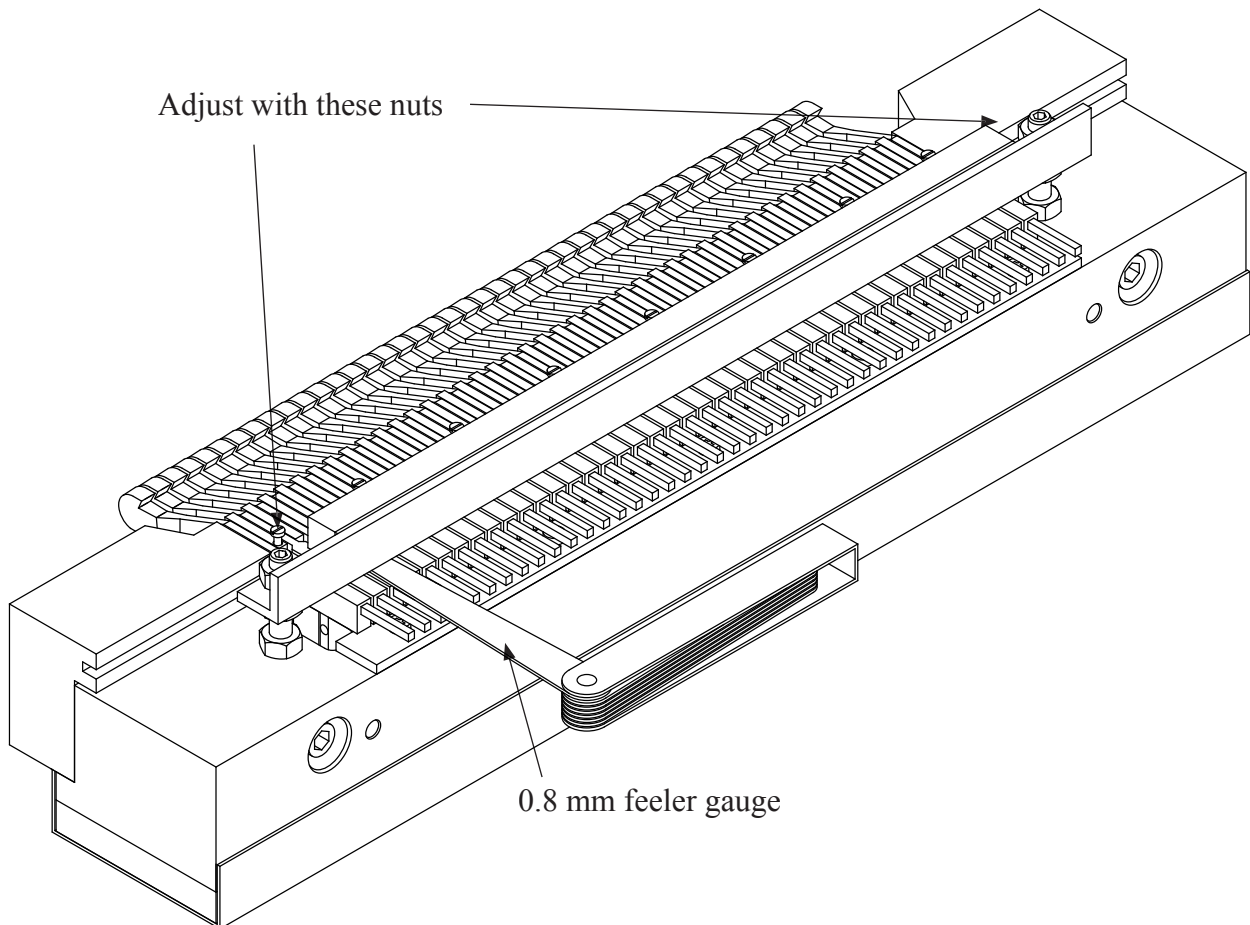

The second adjustment is the pressure the spongelist exerts against the pivot arms. The spongelist works as a return spring for the pivot arms. The correct adjustment is when the spongelist is slightly pressing against the pivot arms, but the pivot arms can still move freely.

Please see figure below:

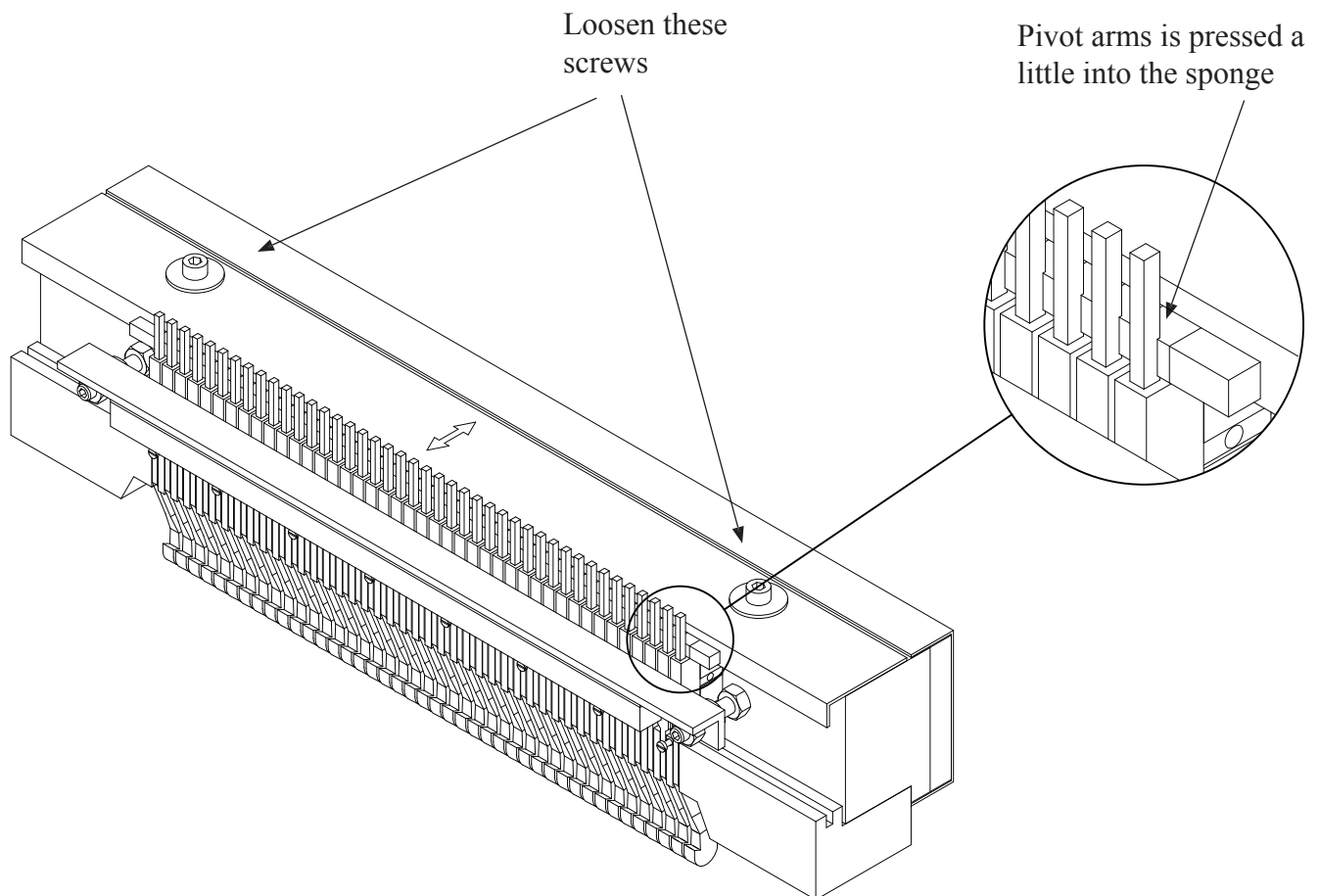



## 4.8 Magnet rack, refitting and adjusting

Please see figure below:

Before putting the magnet rack back on the printer, make sure that the magnet rack itself is adjusted as described in the previous chapter.

When replacing the magnet rack in the printer:

Put in the four fastening screws, but do not tighten them. Slide the magnet rack horizontally away from the printer, so that the magnet rack is touching the horizontal adjustment screws. This will ensure that the magnet rack is in exactly the same position as before it was taken off the printer.

See next chapter regarding correct adjustment of the magnet racks.

Note! All explanations refer to one magnet rack, but these adjustments must be done on all four magnet racks.

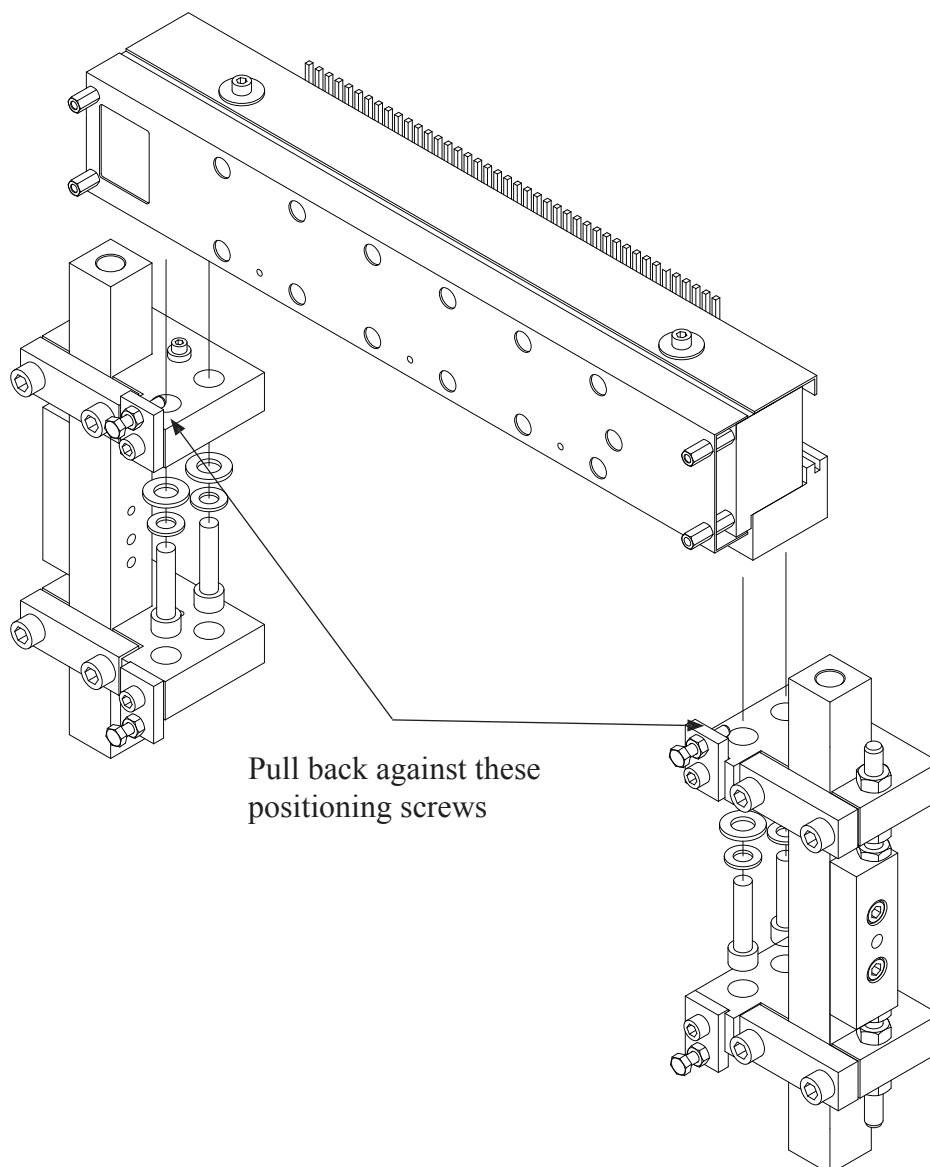

The magnet rack must be adjusted in two directions, horizontal and vertical. The horizontal adjustment is done first. This adjustment positions the magnet rack correctly in relation to the short pivot arms. If the printer prints too many or too few dots, the horizontal adjustment could be the problem.

Then the vertical adjustment is done. This adjustment will affect the pressure the pivot arms put on the printing pins. This directly affects the shape of the printed dots.

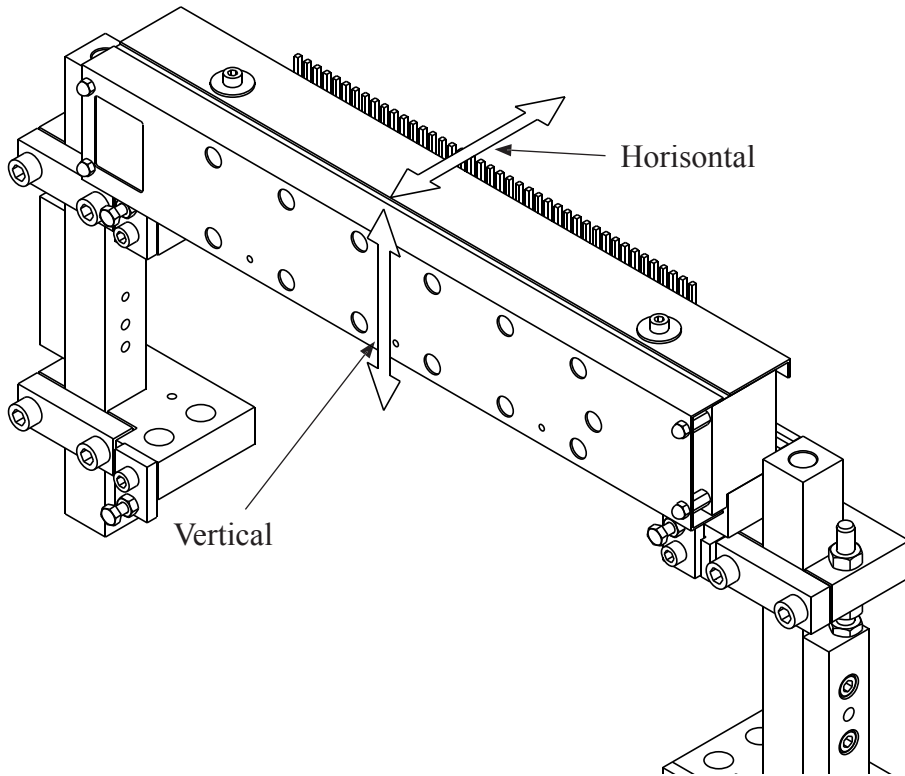

To be able to adjust the magnet rack correctly, it is necessary to put the printer in “printing position”.

This is done by rotating the main belt by hand until the arrows at the ends of the shaft are pointing in the opposite direction of each other. It is possible to get the mechanism to balance in this place, but you can also lock the shafts with e.g. a self locking wrench (“vice-grip” pliers).

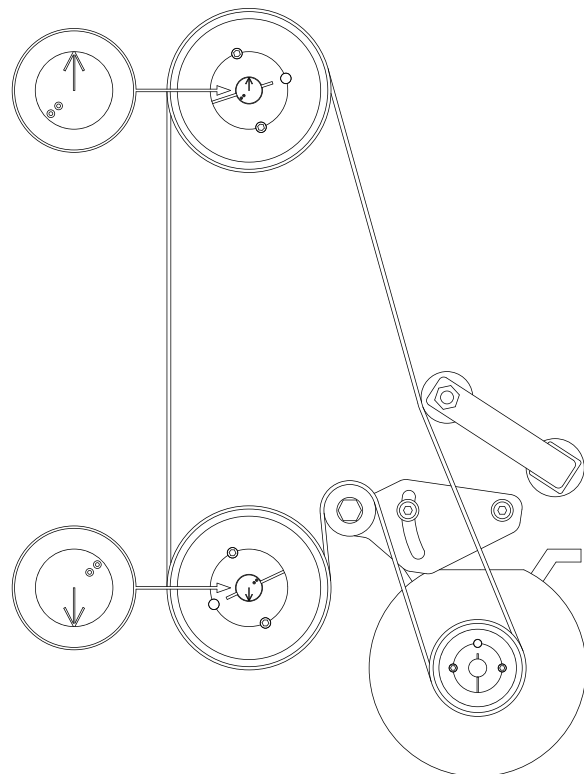

When the arrows at the end of the shafts are pointing in the opposite direction of each other, the short pivot arms will be approx. positioned like in the figure below:

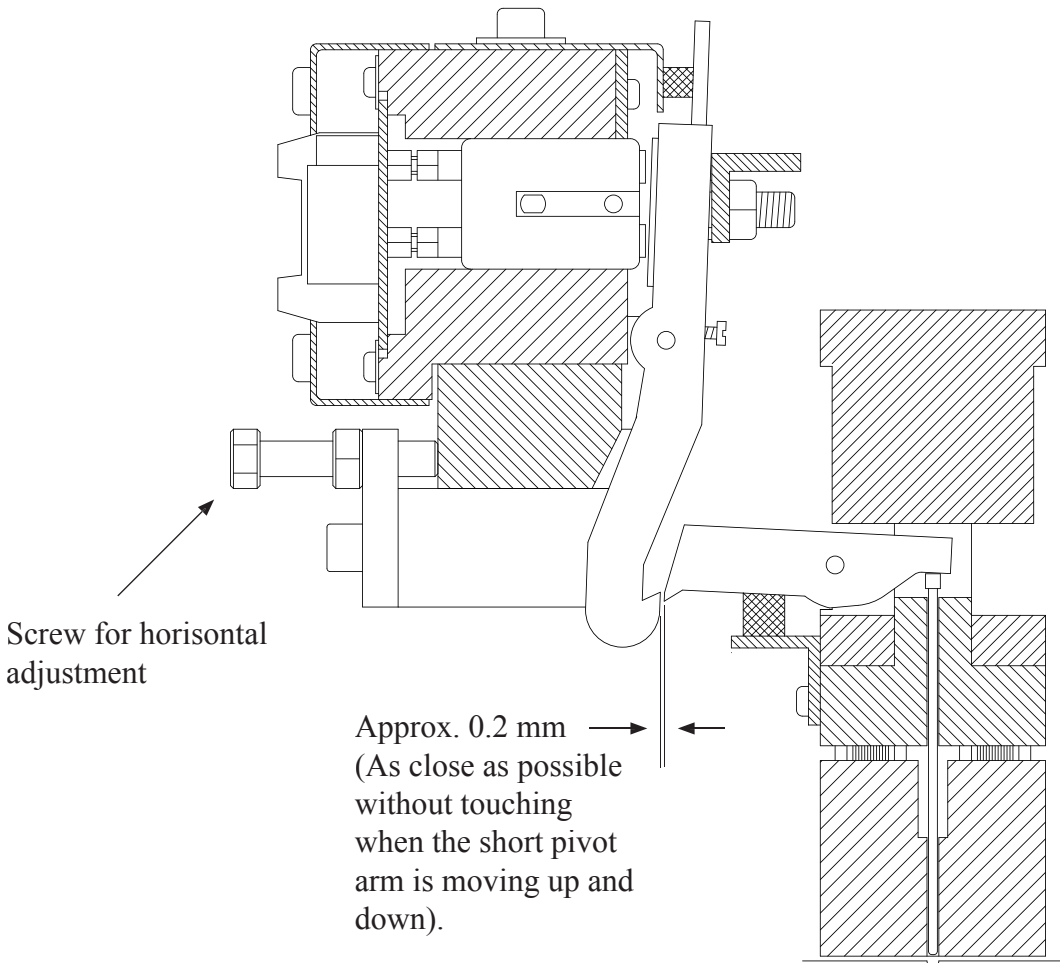

The gap between the long and the short pivot arm should be approx. 0.2 mm. When adjusting this, make sure that the gap is even for all the pivot arms and the same on both ends of the magnet rack.

**How to adjust:**

Observe that the screw for horisontal adjustment will not pull the magnet rack outwards, they will only push inward.

So the best way of doing this, is to loosen the four fastening bolts holding the magnet rack. Then unscrew the horisontal adjustment screw a little. Now slide the magnet rack outward from the printer, so it touches the horisontal adjustment screws again. Then thighten the four fastening screws just a little so the magnet rack is held firmly in place, but is still able to move. Use the horisontal adjustment screw to move the magnet rack closer to the printer. If this is done in small steps, it is possible to watch the gap getting smaller, and the trick is to stop just before the long pivot arm is touching the short pivot arm.

When the position is correct, thighten the four fastening bolts.

Next is vertical adjustment.

Note! The printer must be in the “printing position” when checking this distance.

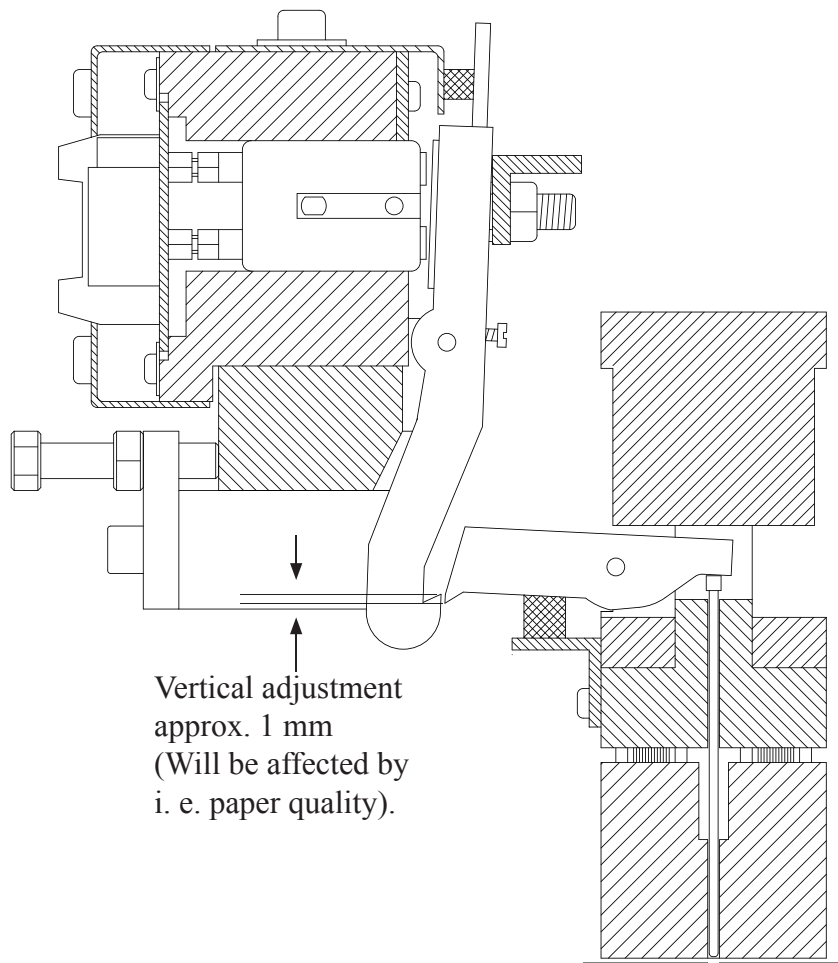

The vertical adjustment of the magnet rack sets the pressure of the printing pins when making dots.

The amount of pressure needed depend on several things. The first (and most important) is the paper quality. The second, is the personal pretesence of dot quality.

So the best way to find the correct level of vertical adjustment, is to first decrease the pressure so the dots will be very faded and weak.

Then readjust the pressure up in small steps until the dot quality is satisfactory. By doing this you can make sure that you are running the printer with just enough pressure to make good dots, but not so much pressure that the printer will be worn/damaged.

From our experience we have found that the vertical adjustment should be approx. 1 mm, but if the braille dots are too weak, you may adjust the magnet rack tighter in small steps (increase the 1 mm distance).

Please see figure on next page:

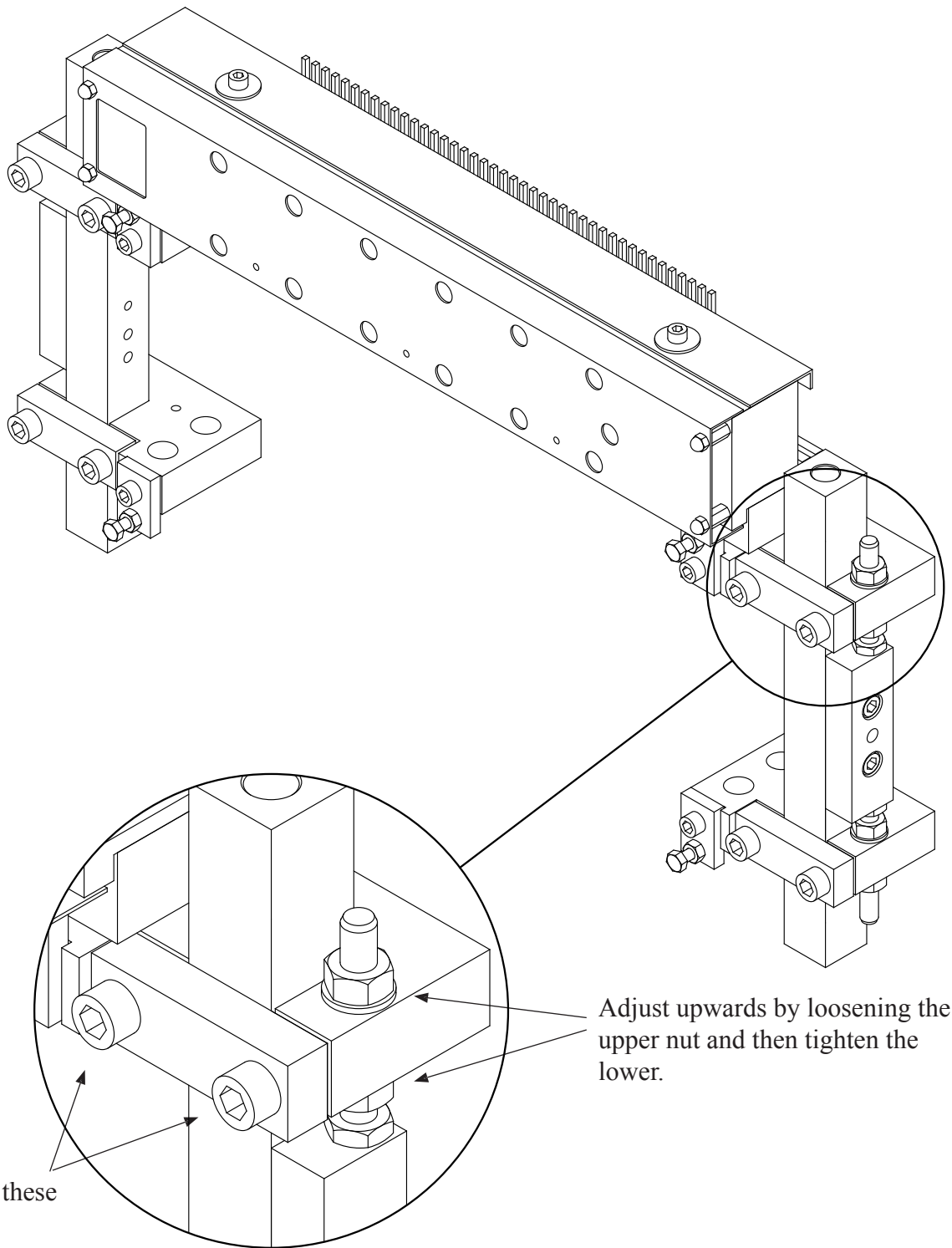

Note! Adjust in small steps, **only 1/4 of a revolution at a time**. Then test the braille quality.



Note! When adjusting the magnet racks vertically, observe that magnet rack A and B must be moved upwards to increase the pressure, and magnet rack C and D must be moved downwards to increase the pressure.  
 (Moving away from the paper increases pressure).

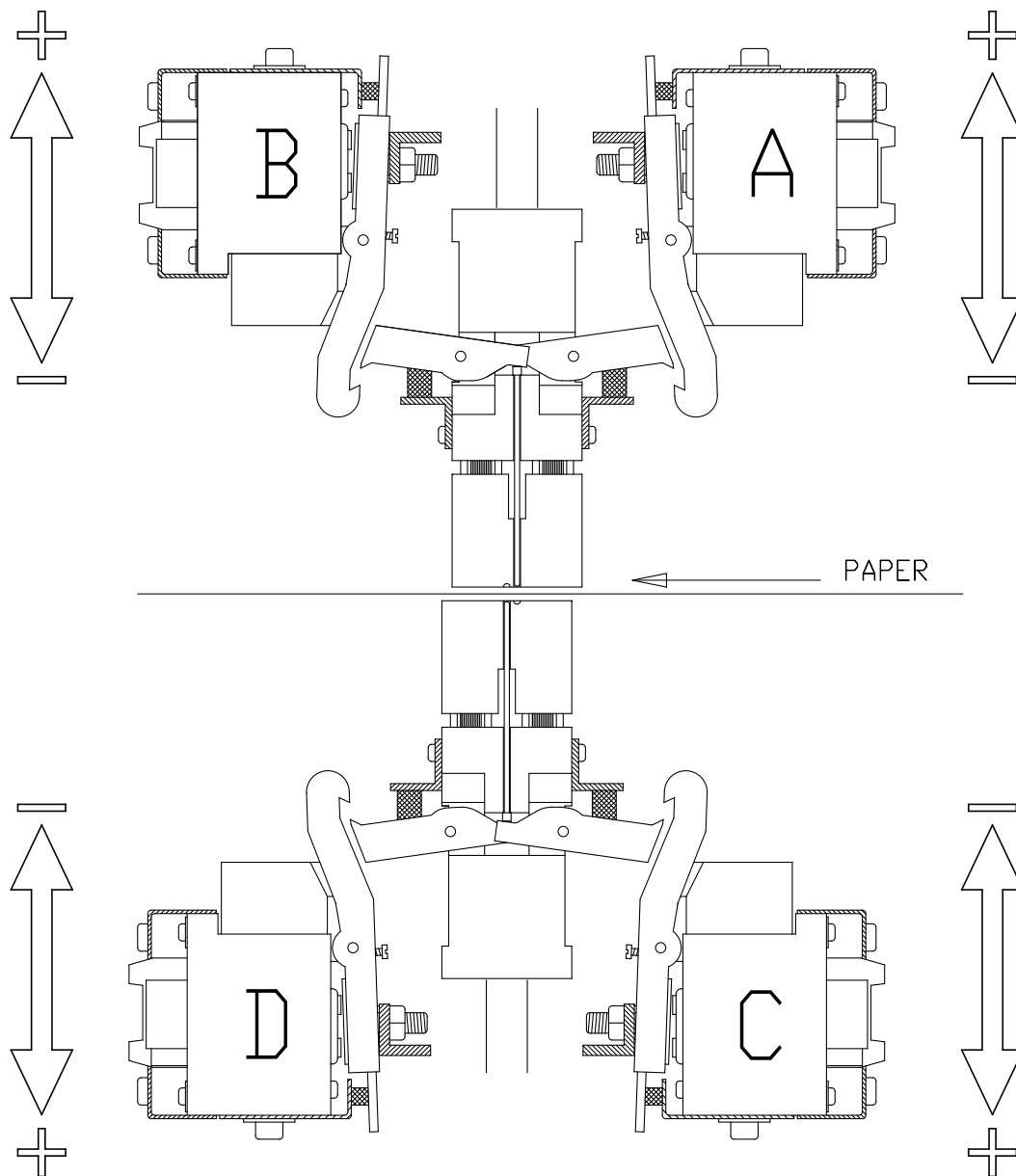

### 4.9 Beam and Paper shoes, overview

Please see the figures below:

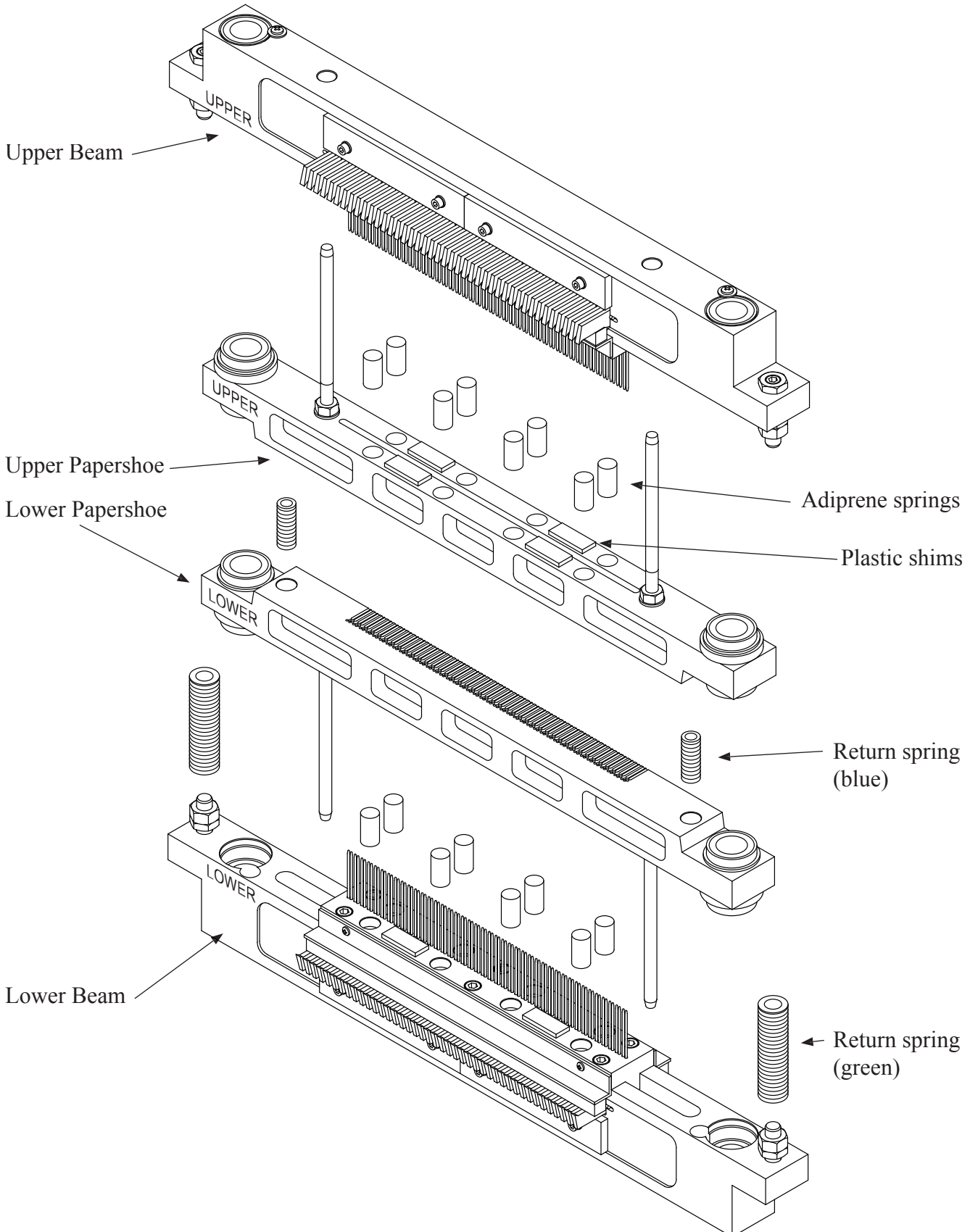

## 4.10 Beam and Papershoes, removal and refitting

To remove the beam and papershoes, some other parts must be removed first. And it should be done in this order:

1. Remove the paper feed assembly
2. Remove the outside paper guide
3. Remove the inside paper guide
4. Remove magnet rack A and B
5. Remove the belt
6. Remove the top frame

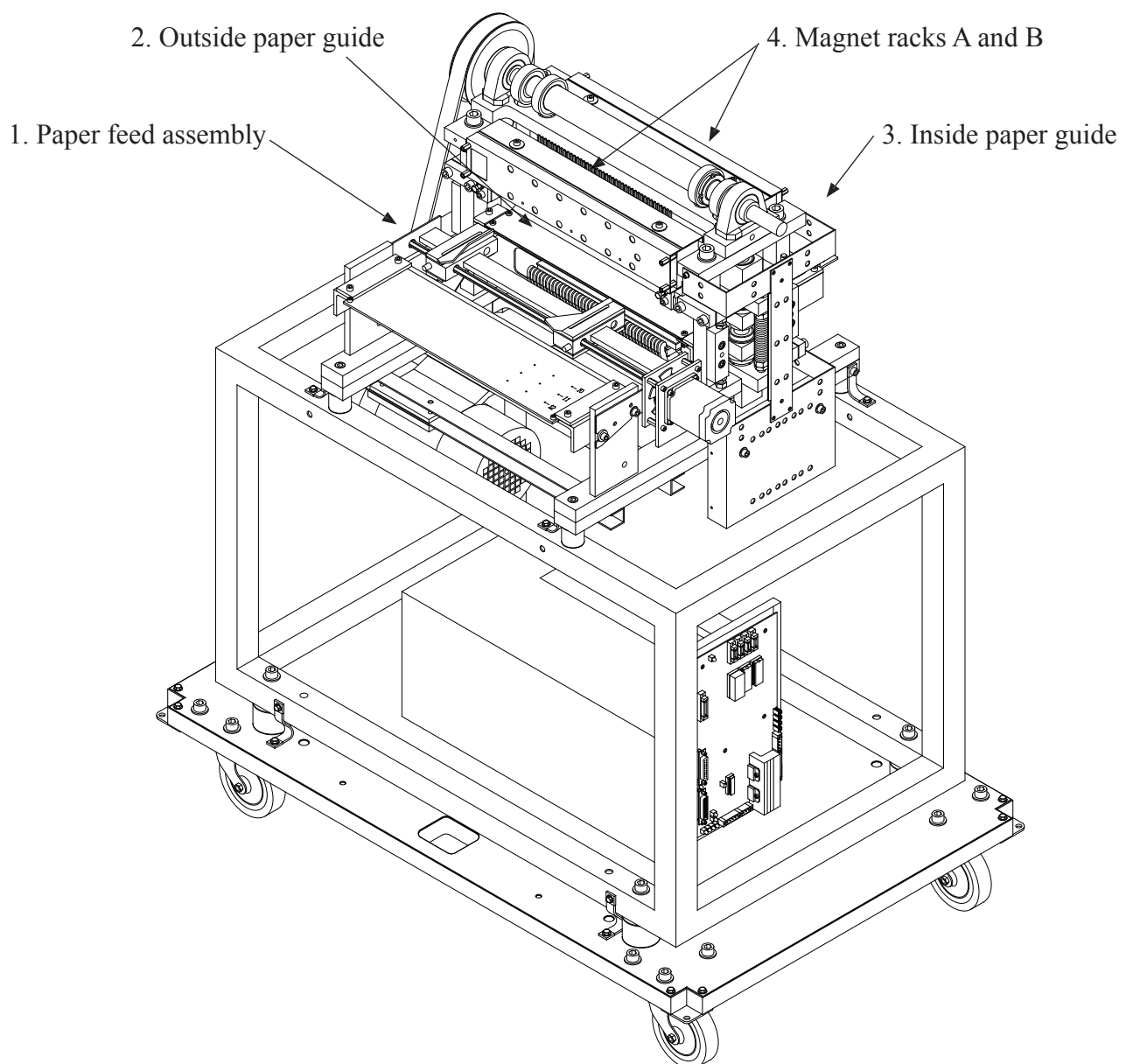



Beam and paper shoes, removal and refitting (continued)

5. Remove the belt.

This is done by loosening the belt tensioner's screws. When this is done, the belt can be lifted off the upper cogwheel. Please see figure to the right.

Loosen these two screws to take off the belt

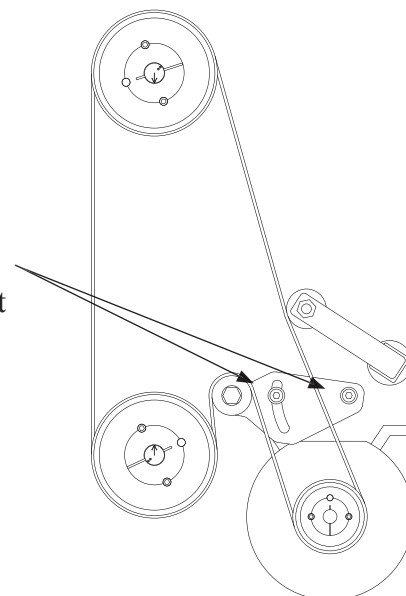

6. Remove the top frame.

Unscrew the screws as indicated on the figure to the right, and then lift the frame carefully upwards and remove.

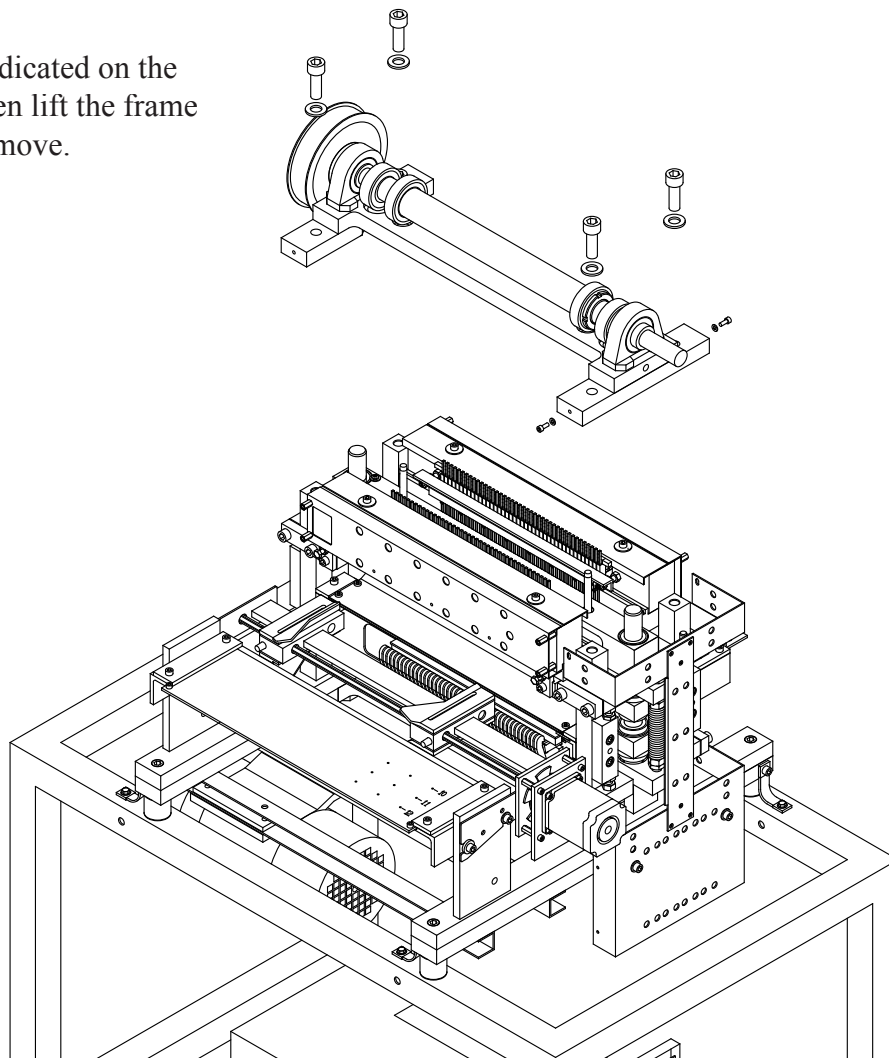

7. Now the beams and paper shoes can be lifted carefully upwards. Assembly is done in the reverse order.

### 4.11 Beam, replacement of short pivot arm

Please see the figures below:

1. Remove the two screws as indicated on the figure. Pull out the short pivot arms, there are 21 pcs. on each shaft.

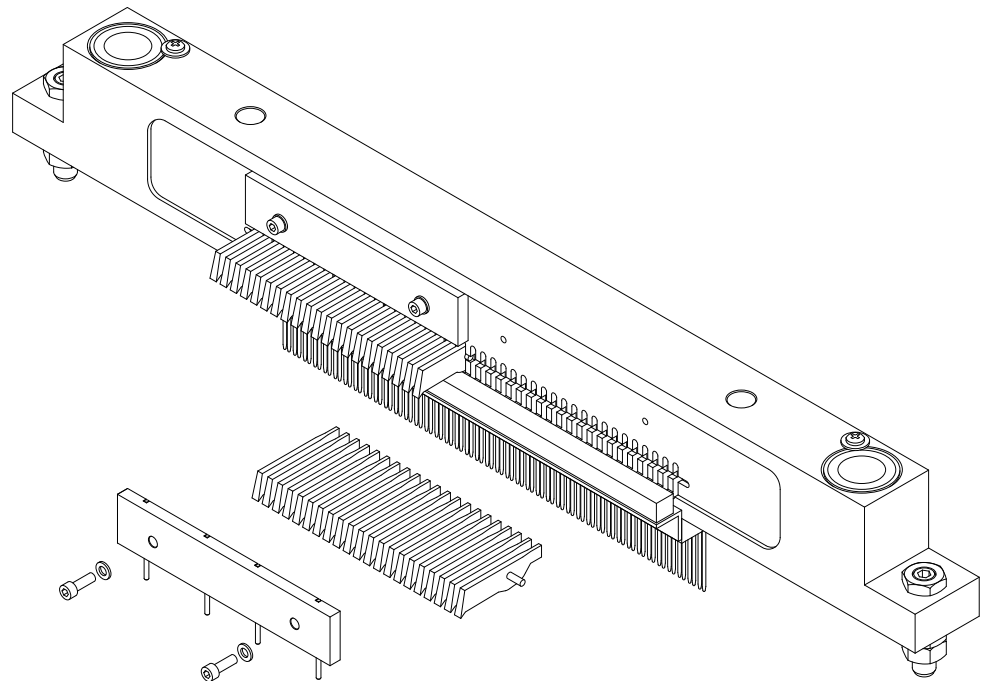

2. Pull out the shaft, and replace the short pivot arm(s).

Assembly is done in reverse order.

Note! When putting the short pivot arms back into the beam, be sure that the printing pins are hanging like in the figure. This is to make room for the short pivot arm.

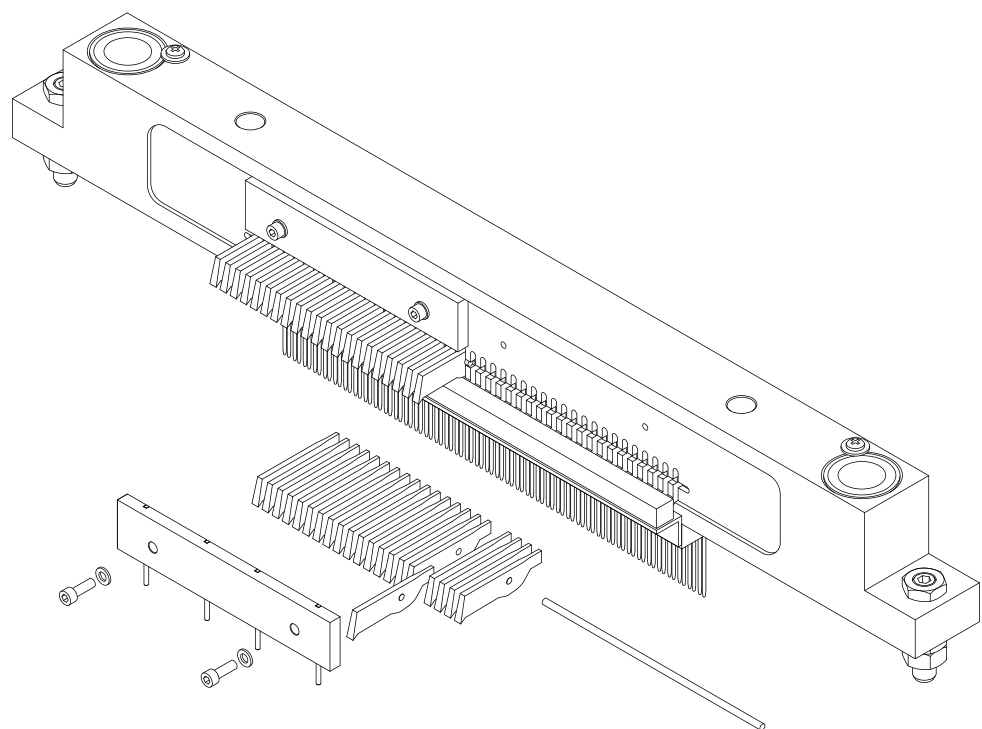

## 4.12 Beam, replacement of printing pin

Please see the figures below:

Remove the six screws as indicated in the figure.

Note! Before the parts are separated, make sure that the beam is held with the printing pins hanging down.

Place the pinguide with the pins on a table, do not turn it upside down or all the pins will fall out!

Now the defect printing pin can be replaced.

Assembly is done in reverse order.

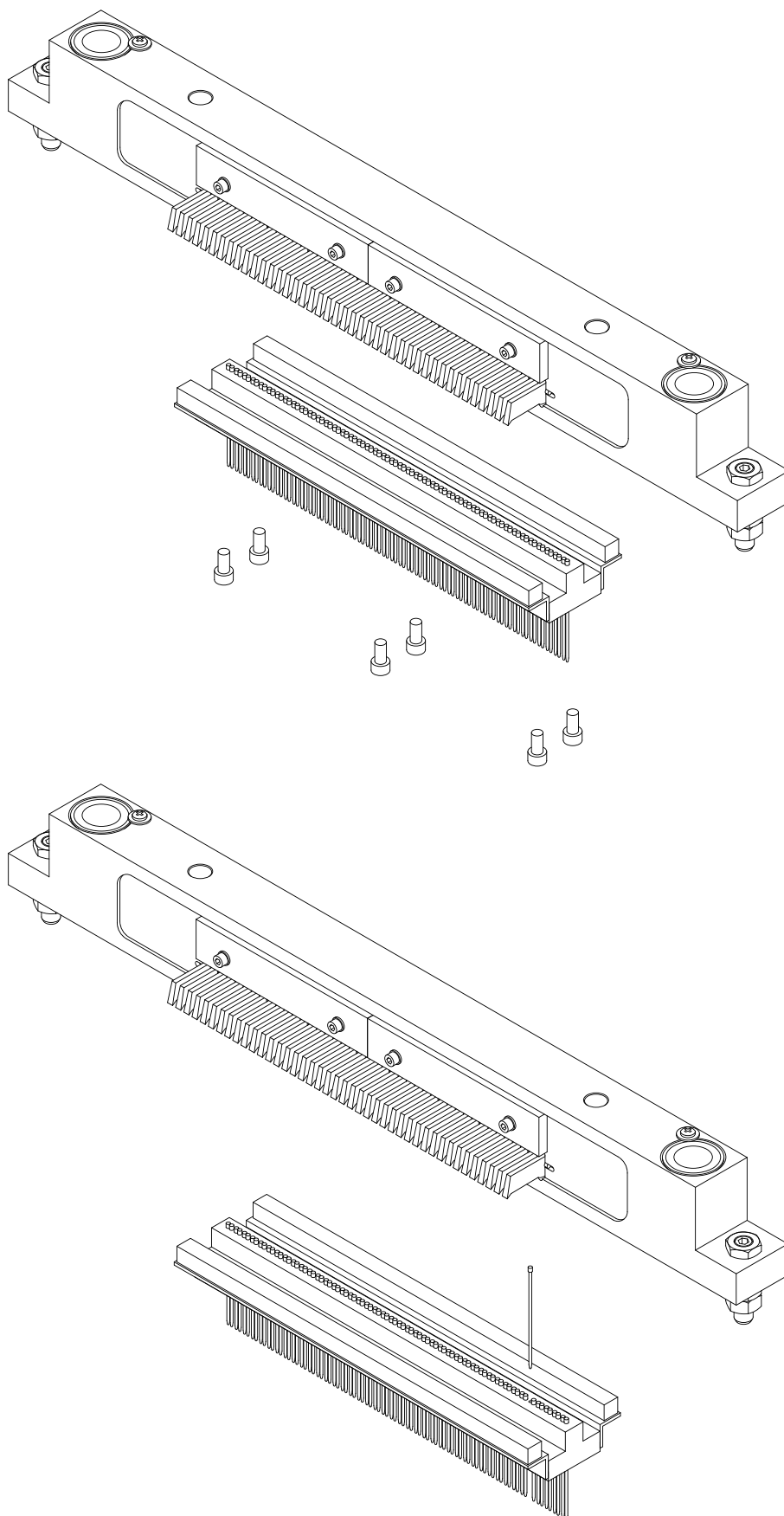

### 4.13 Return spring adjustment

Before performing this adjustment, make sure that the shafts are turned to the correct position. See the marks at the end of the shafts, the arrows must point directly towards each other, like in the figure below.

Then the springs can be adjusted to the correct length, i.e. 68 mm.



Note! It is critically that the length on these two return springs is 68 mm !

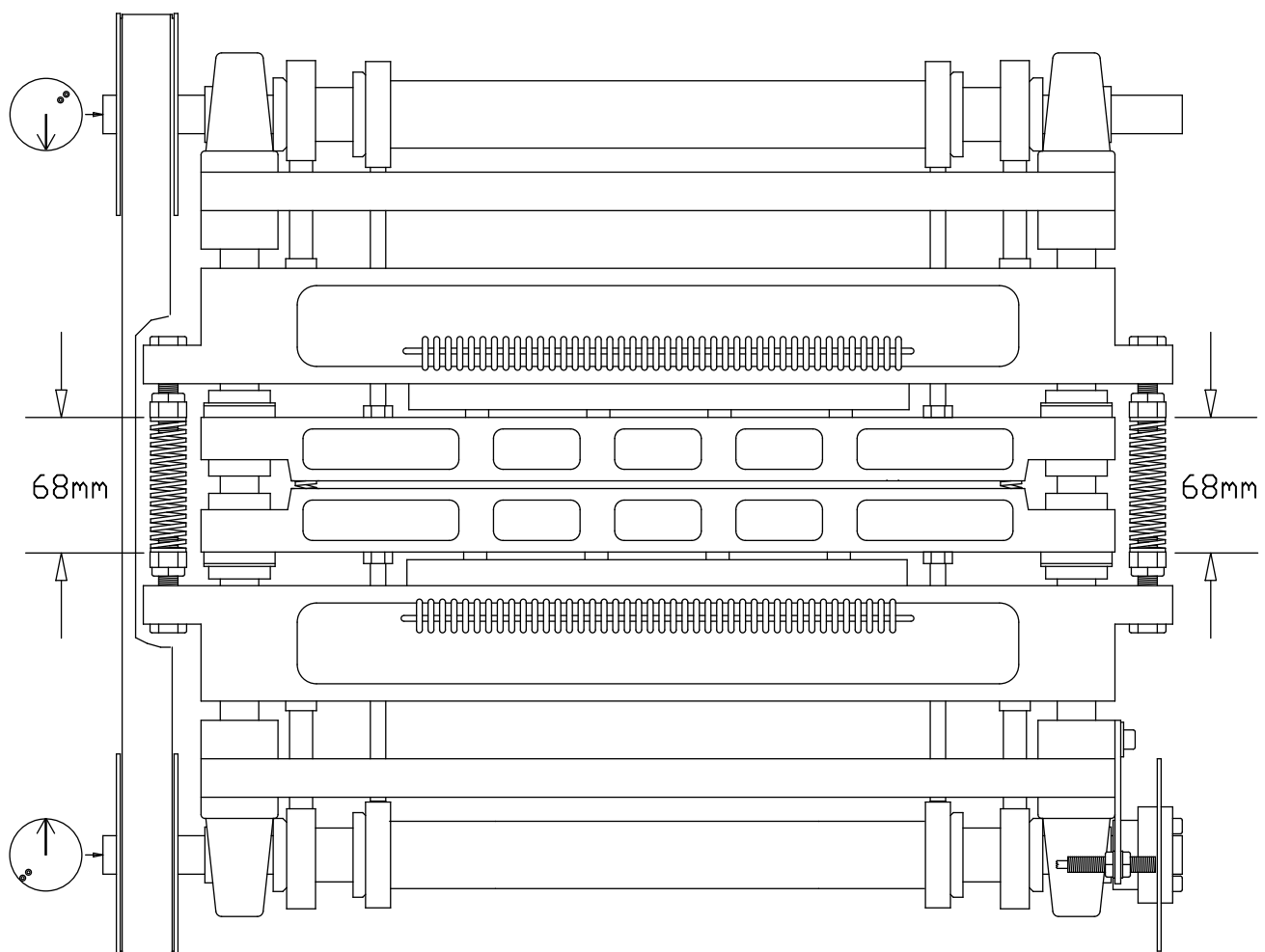

### 4.14 Eccentrics, adjustment

After removing the belt, it is necessary to align the eccentrics.

Put the belt back on, tighten it with the belt tightening wheel (2), and check that the arrows at the end of the shafts (1) are pointing towards each other. See figure below.

If the marks are not aligned like in the figure, it might be necessary to move the belt a notch or two on one of the wheels. This is done by loosening the belt tightening wheel (2) again, and then lift the belt up from the big wheel and move it a notch on the wheel. Then thighten the belt.

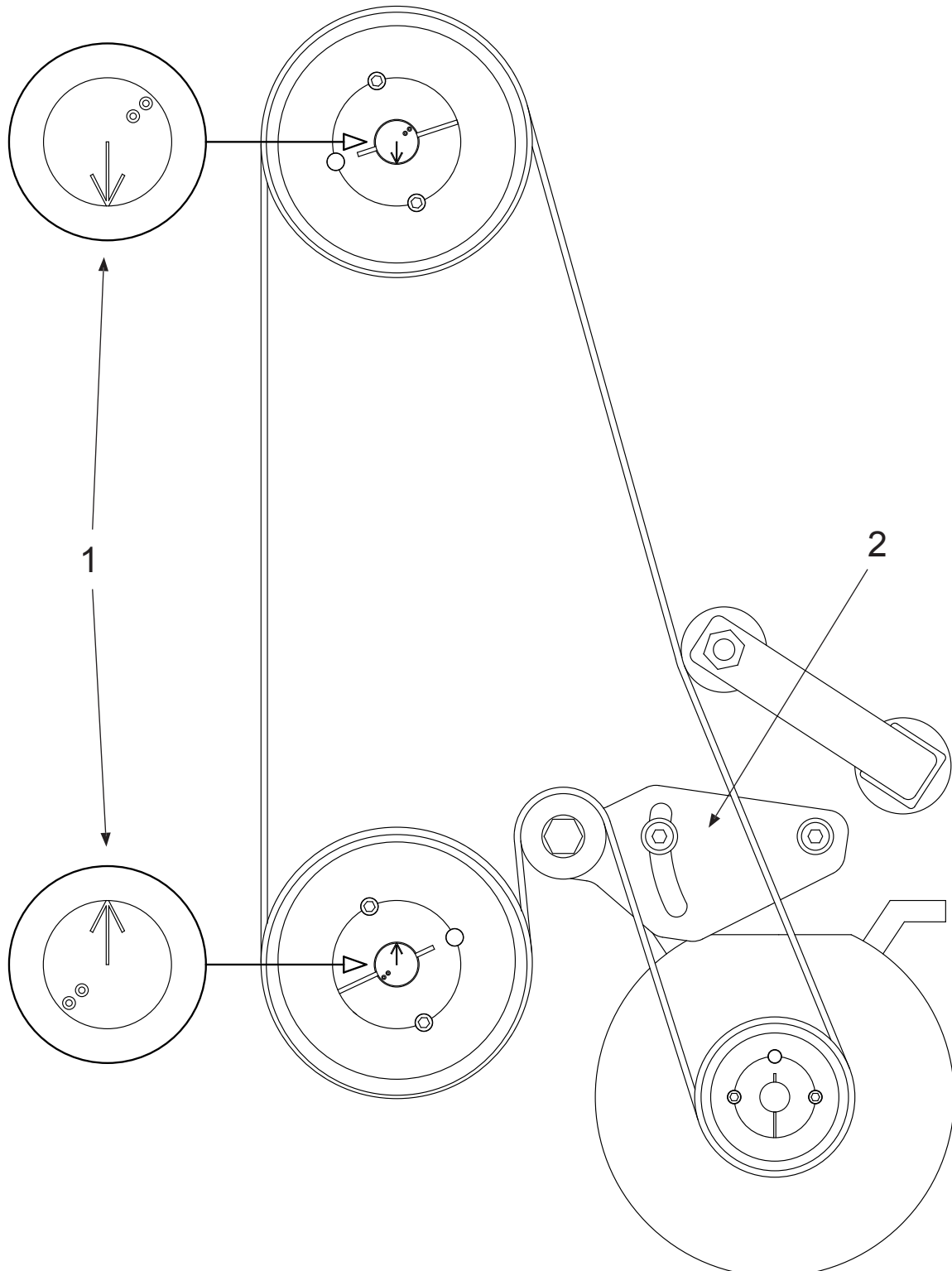

## 4.15 Paper shoes, adjustment

Place a sheet of paper between the paper shoes (P).

Turn the belt so the two points (6) at the end of the shafts (2) are pointing towards each other as shown in the figure below.

Lock the shafts in this position with a vice-grip, e.g. at the end of the shaft (2).

Loosen the locking nuts (1), adjust the push rods (3) by turning them. Adjust the push rods against the inner eccentric bearing (4) until the paper shoes (P) have a light pressure on the paper.

Check that the gap (5) between the press plates and the beam above, is equal on both upper and lower units.

Secure the push rods (3) with the locking nuts (1).



Note! The function of the bearings (4), is to reduce the noise the printer makes while running. It is a common misunderstanding that you can increase the pressure on the papershoes by adjusting these push rods. This does not have any influence on the dot quality!

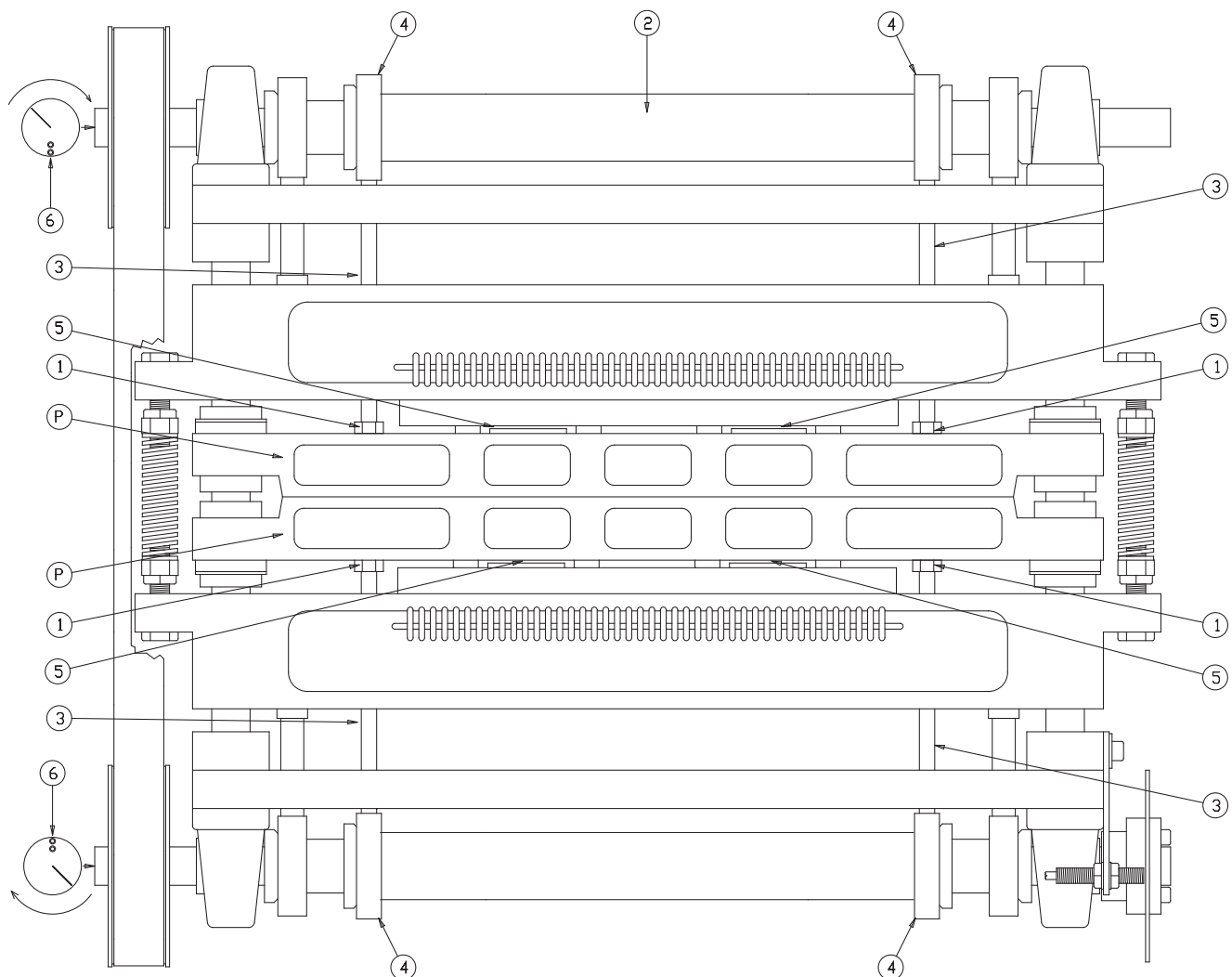

## 4.16 Main sensor wheel, adjustment

The main sensor wheel is placed on the lower shaft, on the opposite end from the belt. Turn the belt in the **opposit** direction of normal rotation (see (A) on the figure below), until the papershoes just meet (see (B) on the figure below). Do not press !

The edge on the timing wheel should now be placed exactly like position (C) in the figure below.

If the edge is not in it's correct position, it must be adjusted.

Keep the shafts in this position while loosen the two screws holding the timing wheel. Turn the timing wheel until the edge on the wheel is placed in the middle of inductive sensor. Then fasten the two screws again.

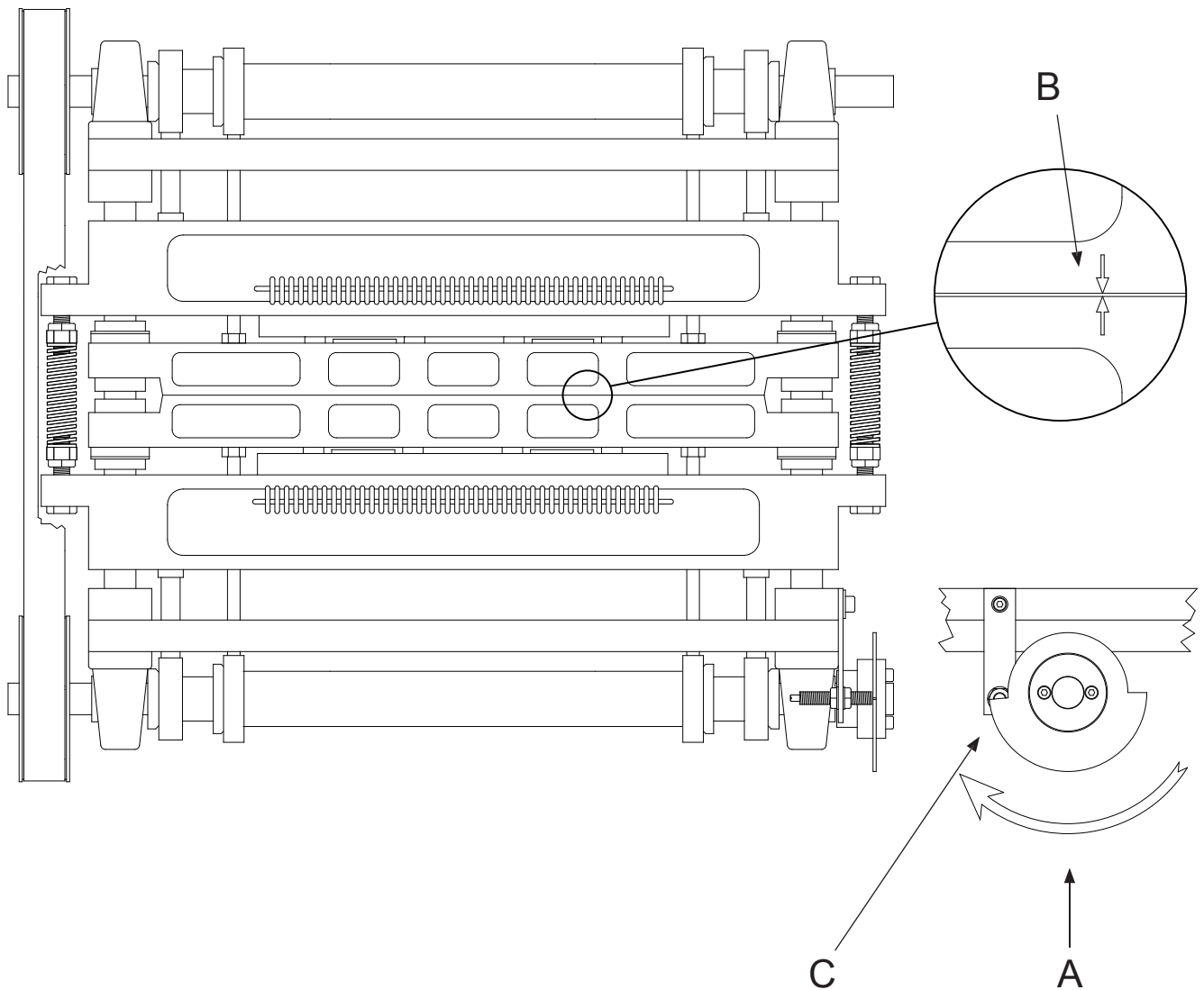

### 4.17 Paper feed assembly, adjustment

If for some reason the paper feed mechanism has been disassembled it could be that the paper will not stop correctly on the marks on the paperguide.

Therefore, it is necessary to adjust the relation between the paper parking position and where the stepping motor is parking.

Loosen the paper feed shaft by unscrewing the two left-hand screws (B) on the sensor wheel.

Note ! Do not loosen the screws for the stepping motor shaft.

Put a sheet of paper into the tractors on the paper feed.

Now the tractor feed shaft can be turned forward or backward until the paper is in the desired position.

Tighten the screws (B) again.

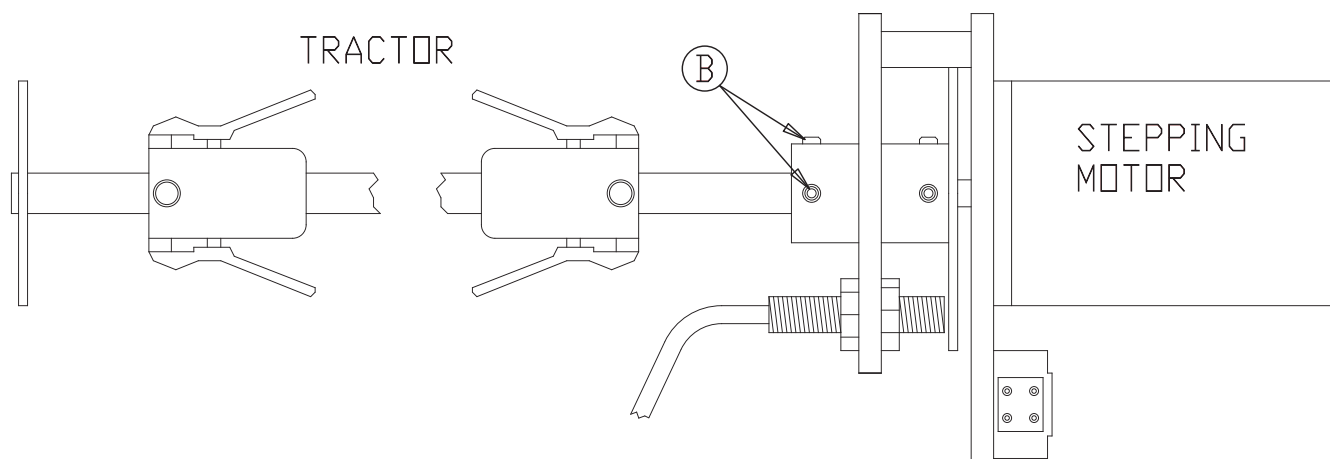



## 4.18 Inductive sensors, adjustment

This printer uses inductive sensors in three places. One for the main timing wheel on the lower shaft, and two are controlling the movement of the paper feed mechanism.

It is possible to check if the inductive sensors are functioning, by looking at the rear end where the cable enters the sensor. Inside the sensor is a little LED lamp that will be lit if a magnetic object is in front of the sensor. The light comes out through some transparent plastic around the cable. So by having the power turned on, and at the same time turning the shafts, the light should go on and off.

When replacing/adjusting the sensors, the gap between the timing wheel and the sensors can be maximum 0.6 mm. See figure below.

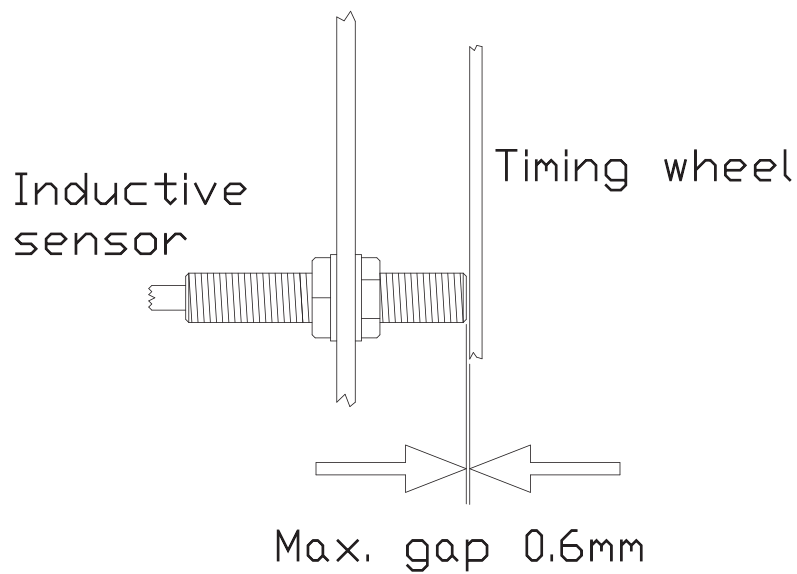

### 4.19 Paper sensor, replacing

This printer has a sensor to detect if paper is present in the printer.

This sensor is situated on the paper guide where the paper enters the printer.

The sensor is an infrared, reflective type, and it functions like this: A little infrared lamp is sending light downward. If there is paper present, the light will be reflected back, and detected by a photo transistor.

If the sensor is defective, it must be replaced. It can be done like this:

Take the paper guide out of the printer. Unscrew first the screws (A), then (B) and then (C). Now the sensor is loose. The assembly is done in reverse order.

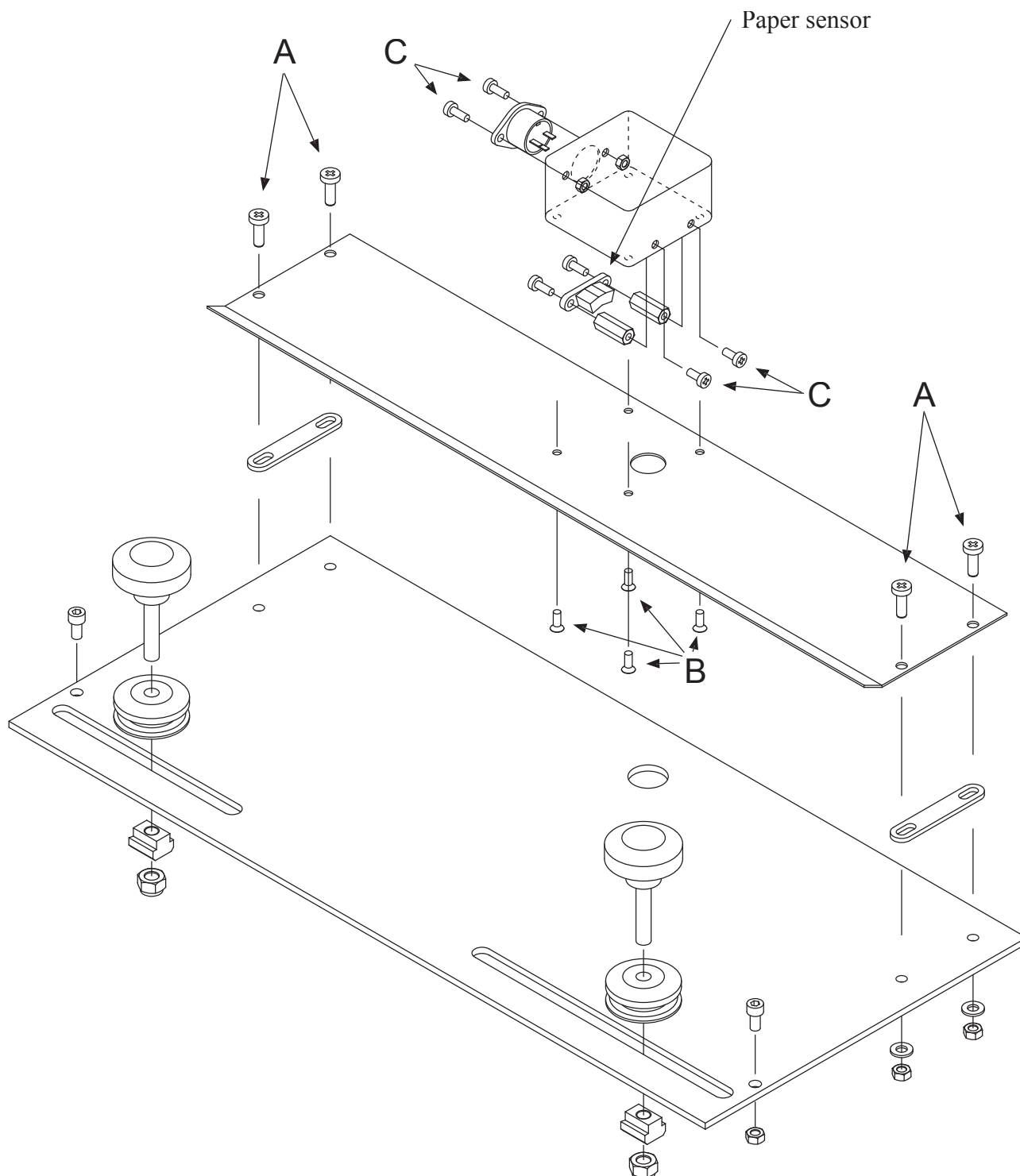

## 4.20 Maintenance

### Weekly (without taking the cover off).

Does the printer print correct braille?

How is the braille dot quality?

Check for any damages on the outside of the cover.

Are the operator panel and display functioning and are powerlamps illuminated?

Do the fans work? Are the fans clean?

If there is a lot of dust from the paper on the paperguides, use a vacuum cleaner.

### Every 500 hours or six months.

Everything of the weekly maintenance.

Is the printer mechanism, electric unit, baseplate and so on clean? Use a vacuum cleaner to remove the dust.

Check the main belt for wear, tear, cracks and check the tension.

Check the tractor belts for wear, tear, and cracks. Be sure to check the small red “spikes” of the tractor belts very carefully. Sometimes these “spikes” are so worn that they will just fall off.

Clean the magnet racks.

Check the sponges for the long pivot arms on the four magnet racks, the sponge should be able to keep the long pivot arms pressed against the support list.

When putting the magnet racks back in, check all the magnet rack adjustments.

Check if the printing pins move freely, and if not do a cleaning of the printing pin guide.

### Every 1000 hours or twelve months.

Everything of the 500 hours or six months maintenance.

Check the four sponges for the short pivot arms, the sponge should be able to keep the short pivot arm pressed all to the end of its travelling distance.

Check the tear and wear on the piston (12 x 56). This can be measured with a caliper, and the length must be between 55.90 to 56.00 mm.

Check if the paper shoes are worn. The printer should be able to give good braille dot quality, but if not, worn papershoes could be the reason.

Lubricate all the stroke ball bearings, using a universal grease with molybdensulfid.

Lubrication should be done as described in figure on the next page.

**Lubrication**

This should be done every 1000 running hours, or approx. once a year.

Lubricate all items marked “1” on the figure below. (These are the only locations in the printer grease may be applied!).

Use a universal grease with molybdensulfid.

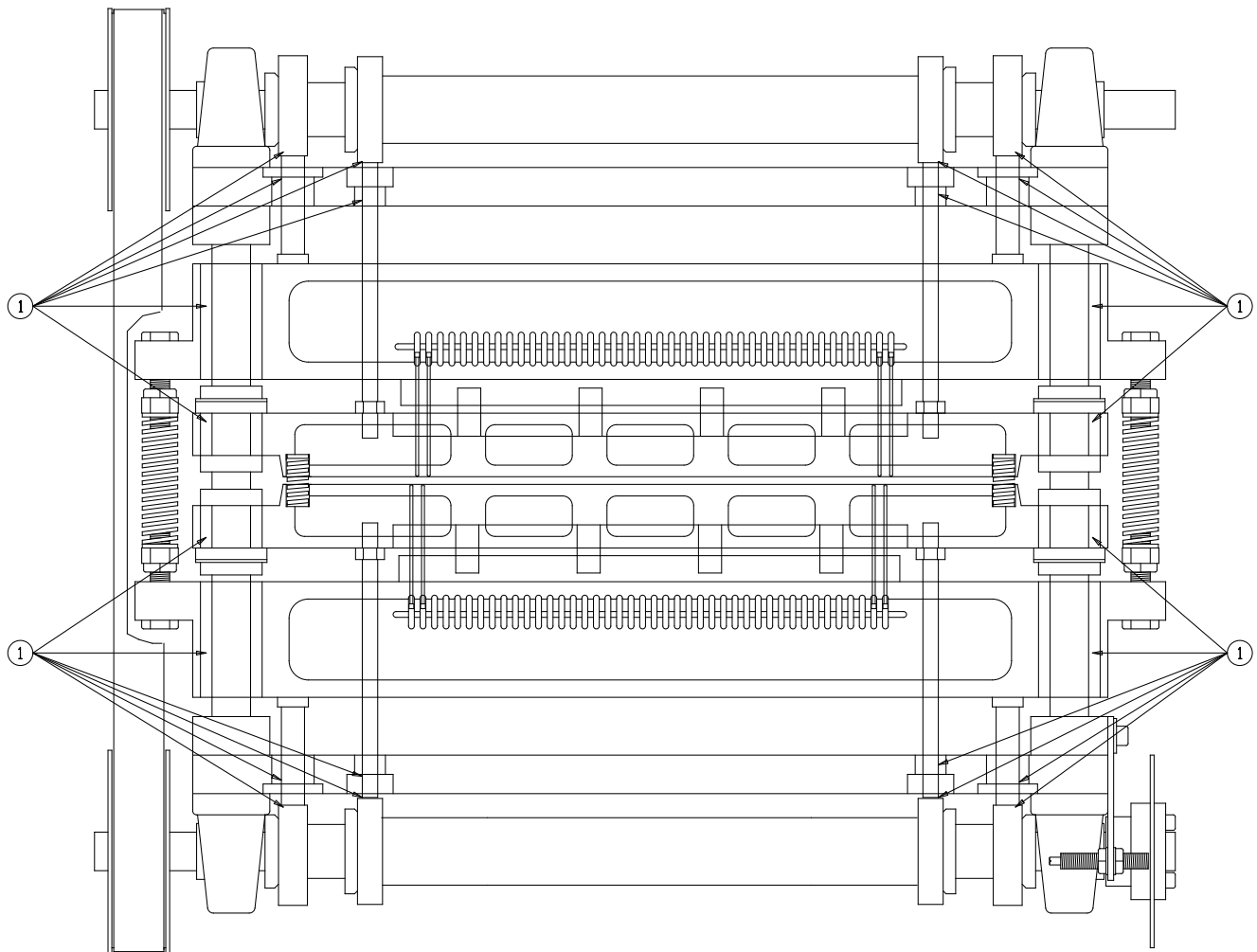

## 5. PARTS - EXPLODED VIEWS

### 5.1 Magnet rack

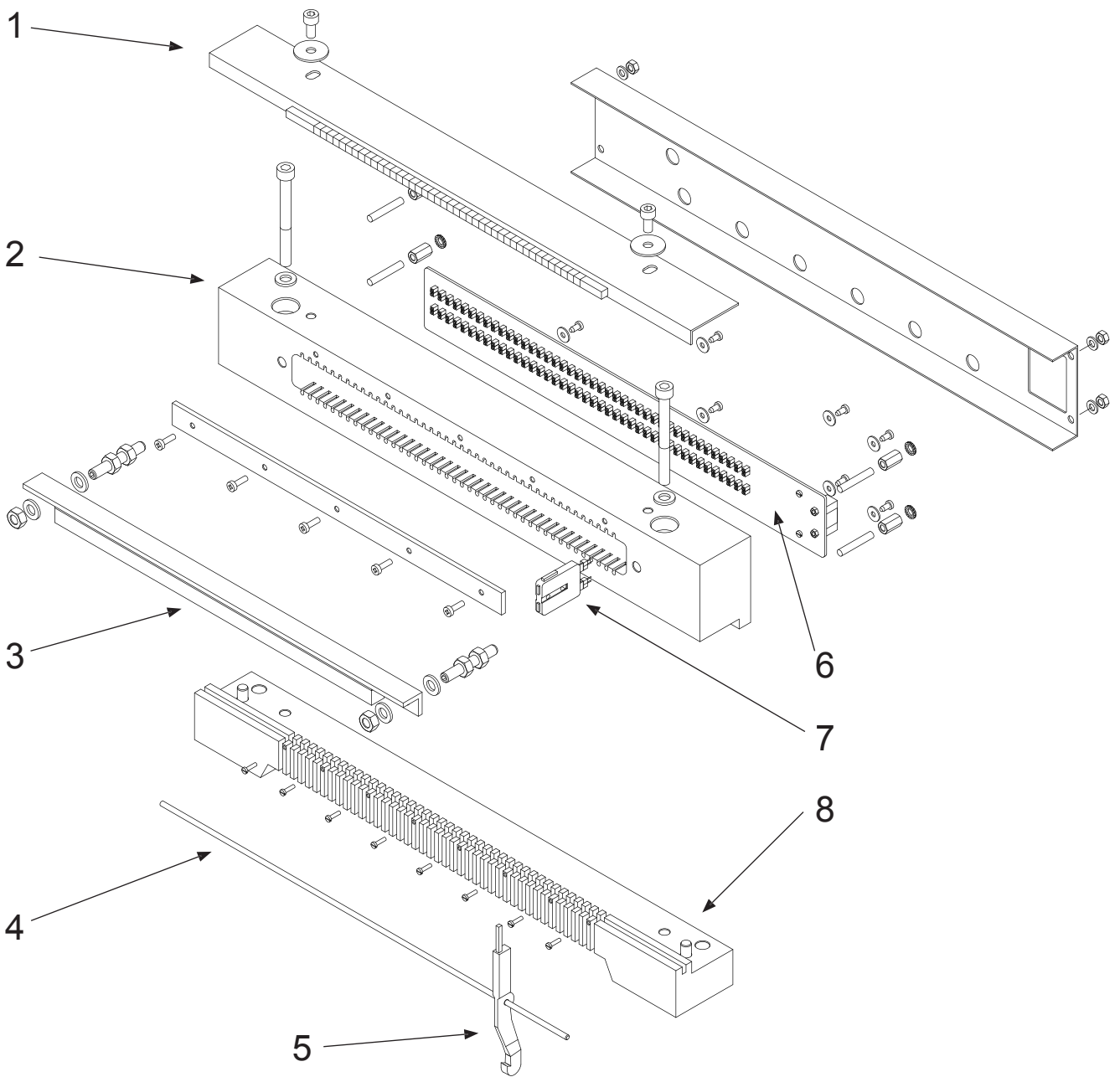

Parts magnet rack

Pos	Name	Quantity pr. rack
1	Spongelist, magnet rack .....	1
2	Magnet rack .....	1
3	Support list, magnet rack .....	1
4	Shaft, long pivot arm.....	1
5	Pivot arm, long.....	42
6	Electronic board, magnet rack .....	1
7	Magnet .....	42
8	Guide list, magnet rack .....	1

5.2 Beam

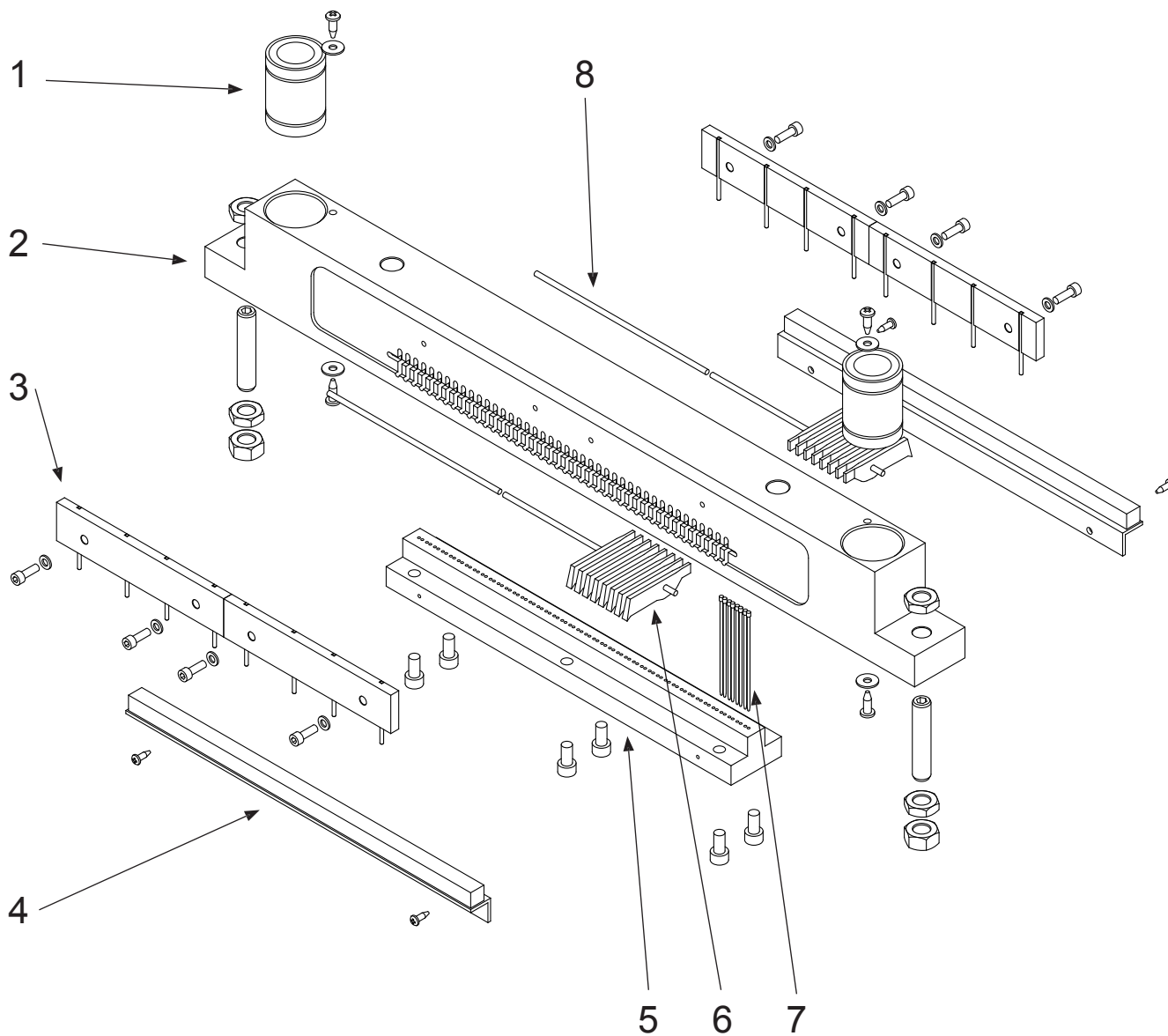

Parts beam (upper and lower)

Pos	Name	Quantity pr. beam
1	Stroke ball bearing Ø20 .....	2
2	Beam, (upper and lower) .....	1
3	Fastener for shaft short pivot arm .....	4
4	Sponge list for short pivot arm .....	2
5	Pin guide .....	1
6	Short pivot arm .....	84
7	Printing pin, length = 64.5 mm .....	84
8	Shaft, short pivot arm .....	4

### 5.3 Paper shoe

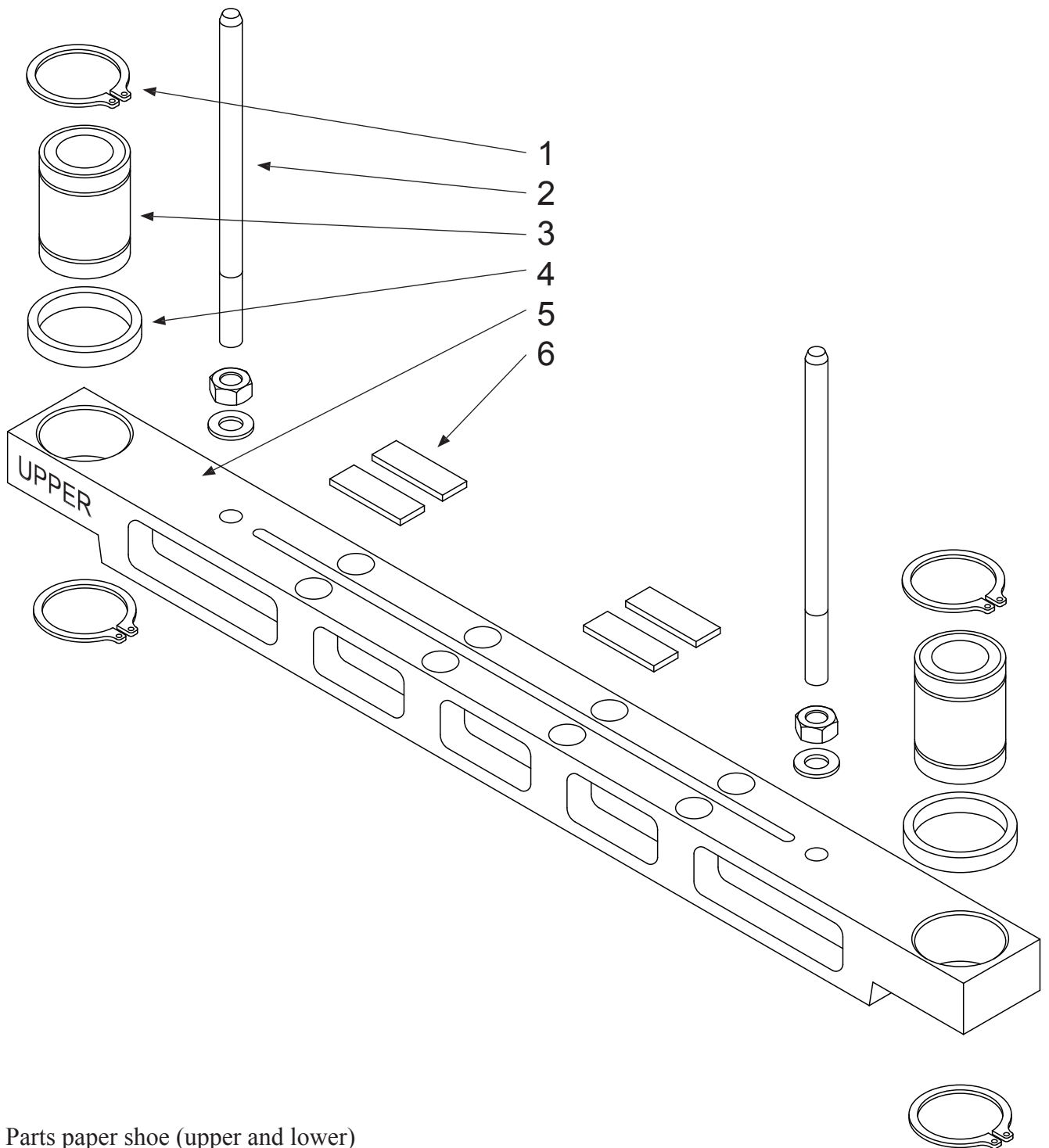

Parts paper shoe (upper and lower)

Pos	Name	Quantity pr. shoe
1	Retaining ring .....	4
2	Adjustment screw (push rod) .....	2
3	Stroke ball bearing Ø20 .....	2
4	Spacer .....	2
5	Paper shoe (upper and lower) .....	1
6	Plastic shims .....	4

### 5.4 Paper feed

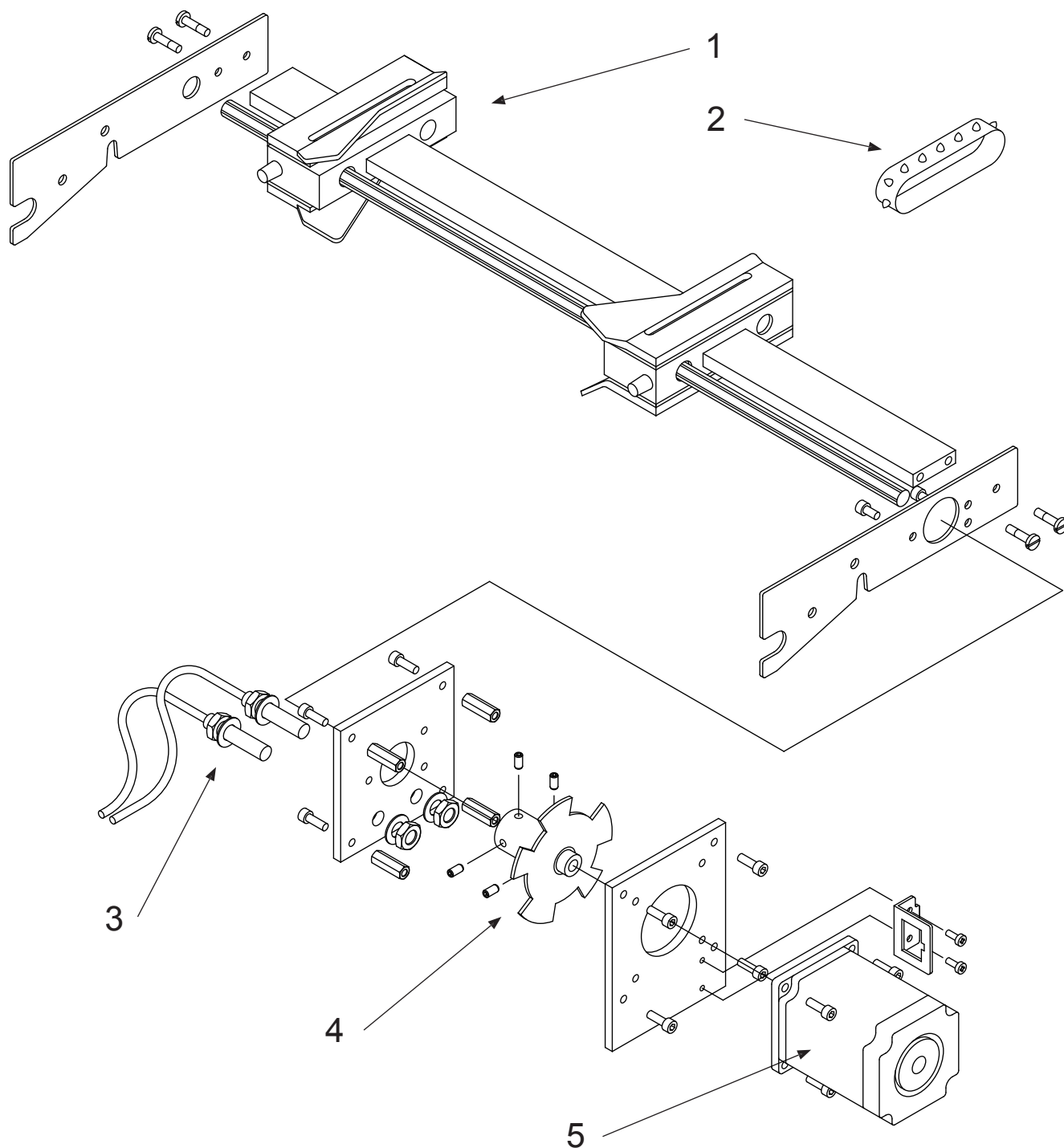

Parts paper feed

Pos	Name	Quantity
1	Paper feed tractor .....	2
2	Belt for tractor .....	2
3	Inductive sensor (no. 5 and 6) .....	2
4	Timing wheel .....	1
5	Stepping motor.....	1



5.5 Shaft, belt

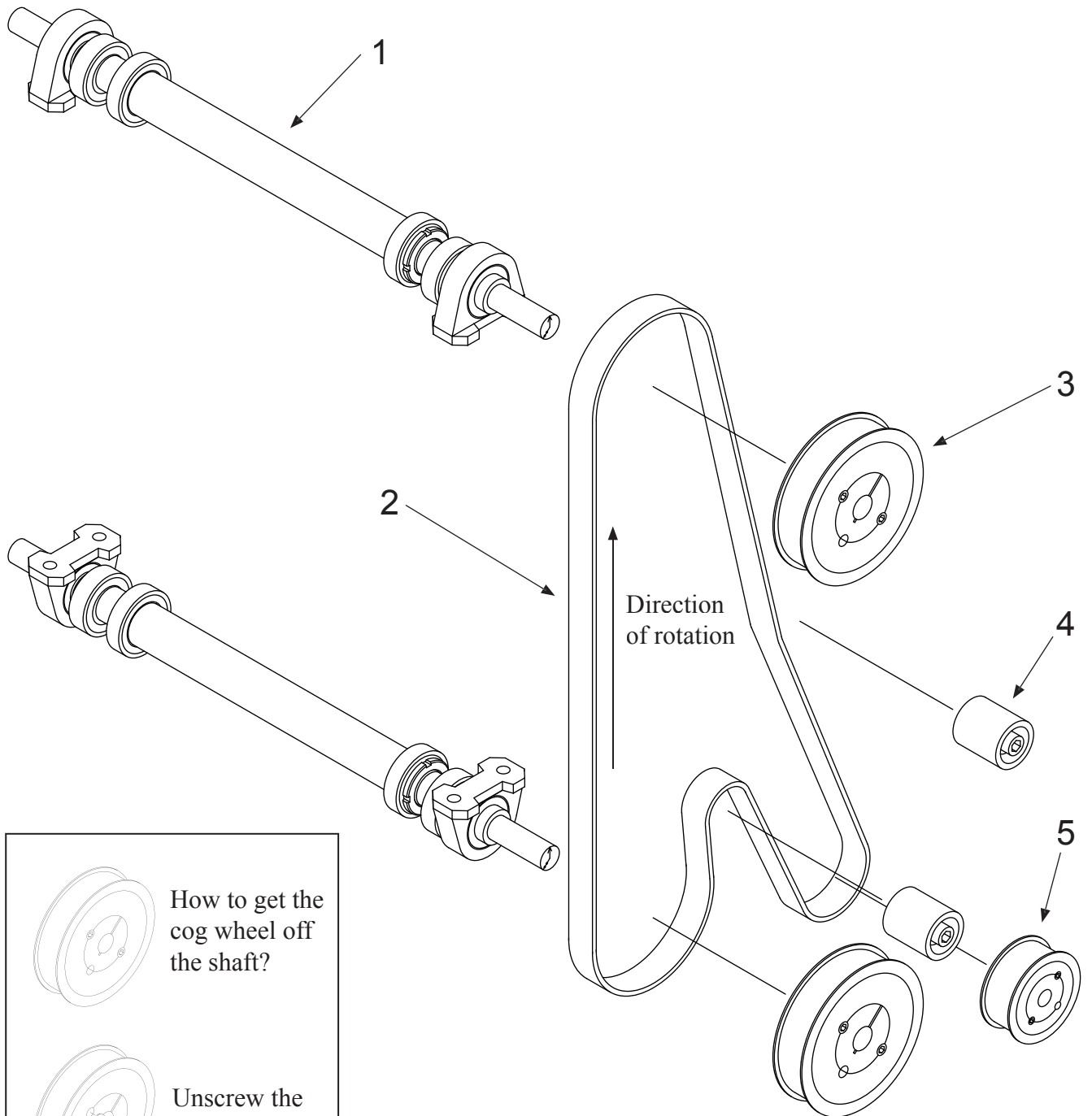

How to get the cog wheel off the shaft?

Unscrew the two screws.

Place one of the screws in the third hole, and screw it inwards until the wheel is loose.

Parts shaft, belt

Pos	Name	Quantity
1	Shaft, complete with bearings .....	2
2	Belt 640 L.....	1
3	Cog wheel 40 L 100.....	2
4	Belt tensioner .....	2
5	Cog wheel 22 L 100.....	1

Shaft, exploded view

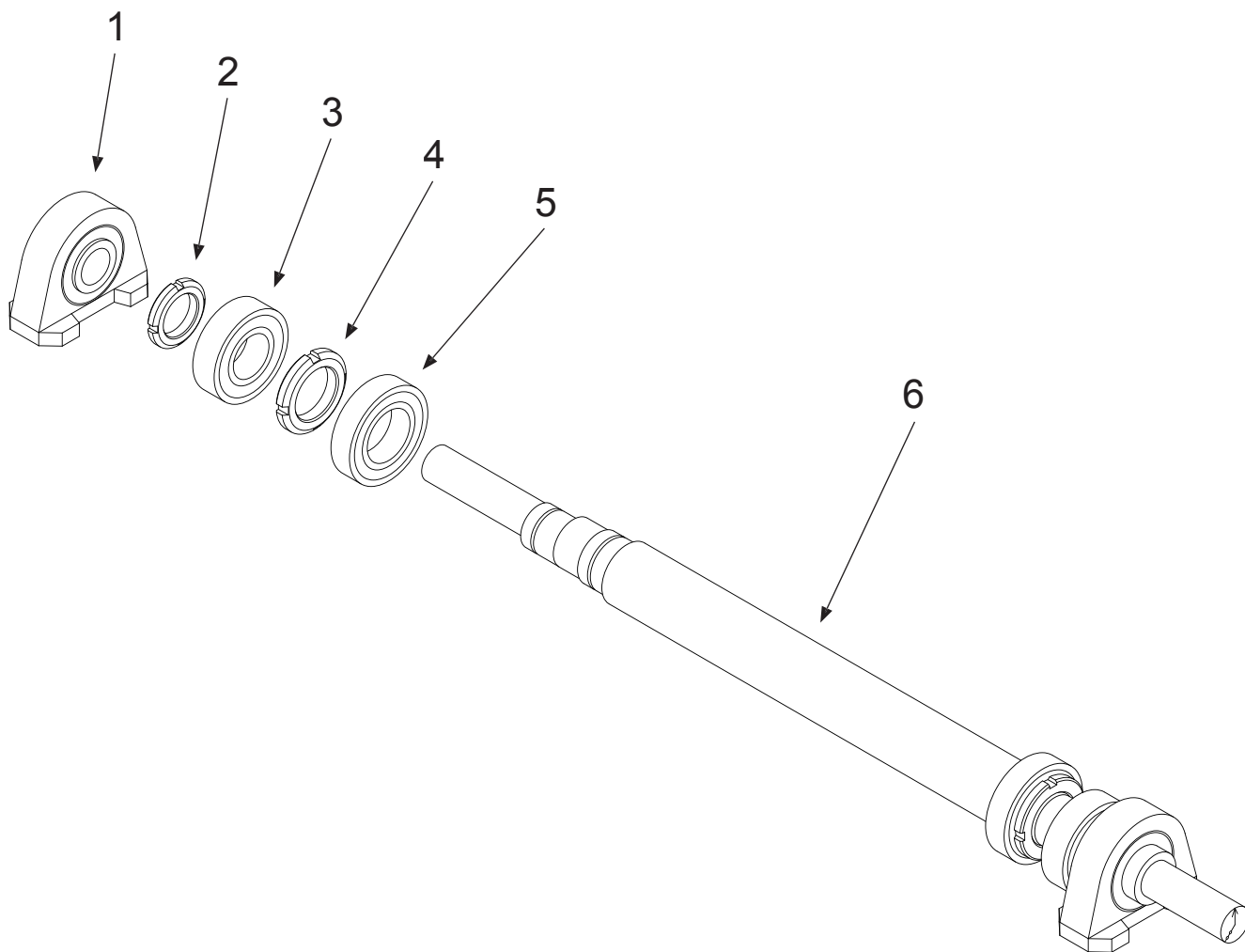

Parts shaft, exploded

Pos	Name	Quantity pr. shaft
1	Main bearing with housing .....	2
2	Nut KM5 .....	2
3	Bearing outer eccentric 6205 2Z.....	2
4	Nut KM6 .....	2
5	Bearing inner eccentric 6006 2Z.....	2
6	Shaft .....	1

5.6 Top and bottom frame, exploded view

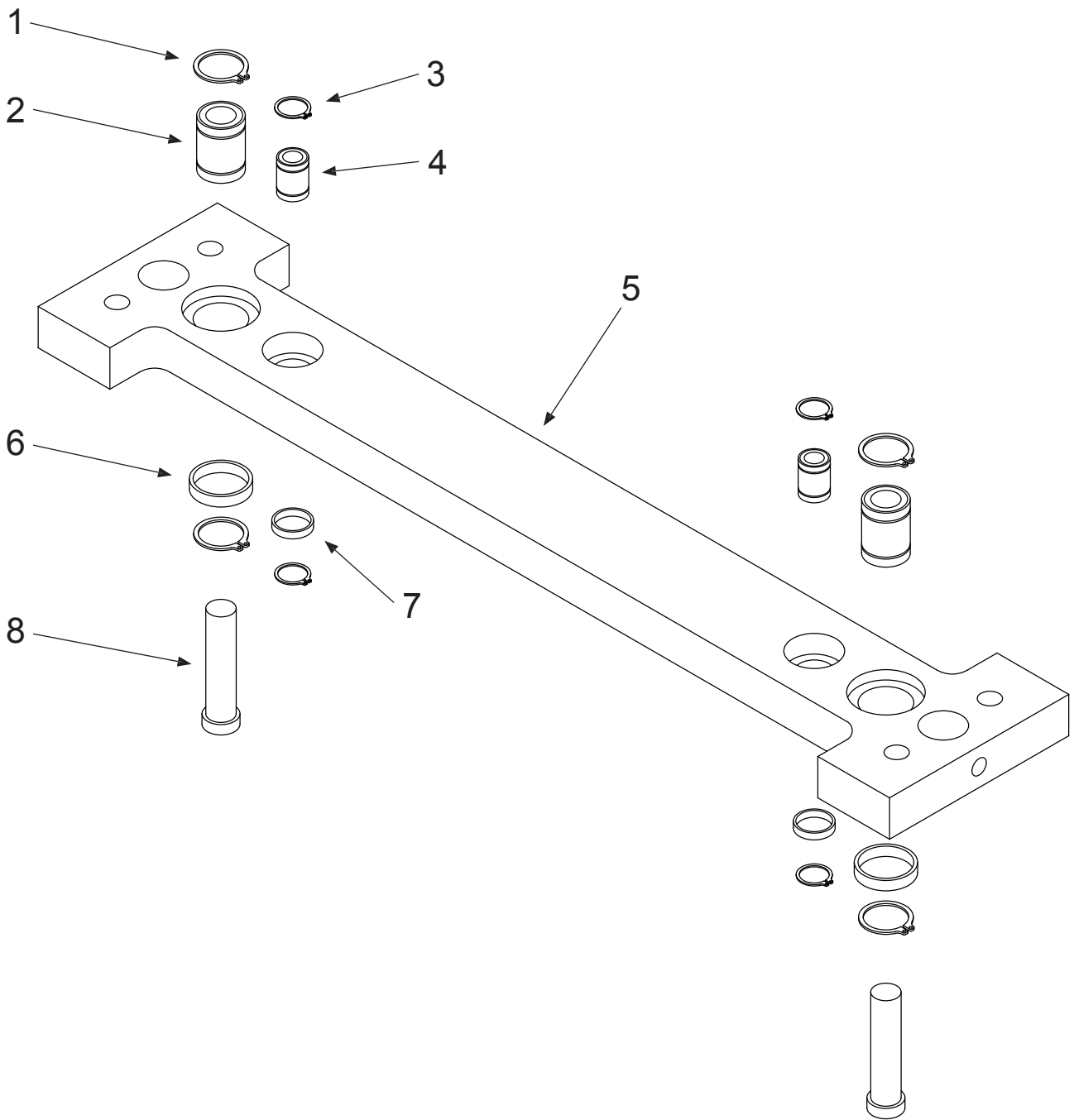

Parts top and bottom frame, exploded

Pos	Name	Quantity pr. frame
1	Locking ring Ø22 .....	4
2	Stroke ball bearing Ø12 .....	2
3	Locking ring Ø16 .....	4
4	Stroke ball bearing Ø8 .....	2
5	Frame .....	1
6	Spacer Ø22 .....	2
7	Spacer Ø16 .....	2
8	Push rod Ø12X56 .....	2

Frame, exploded view

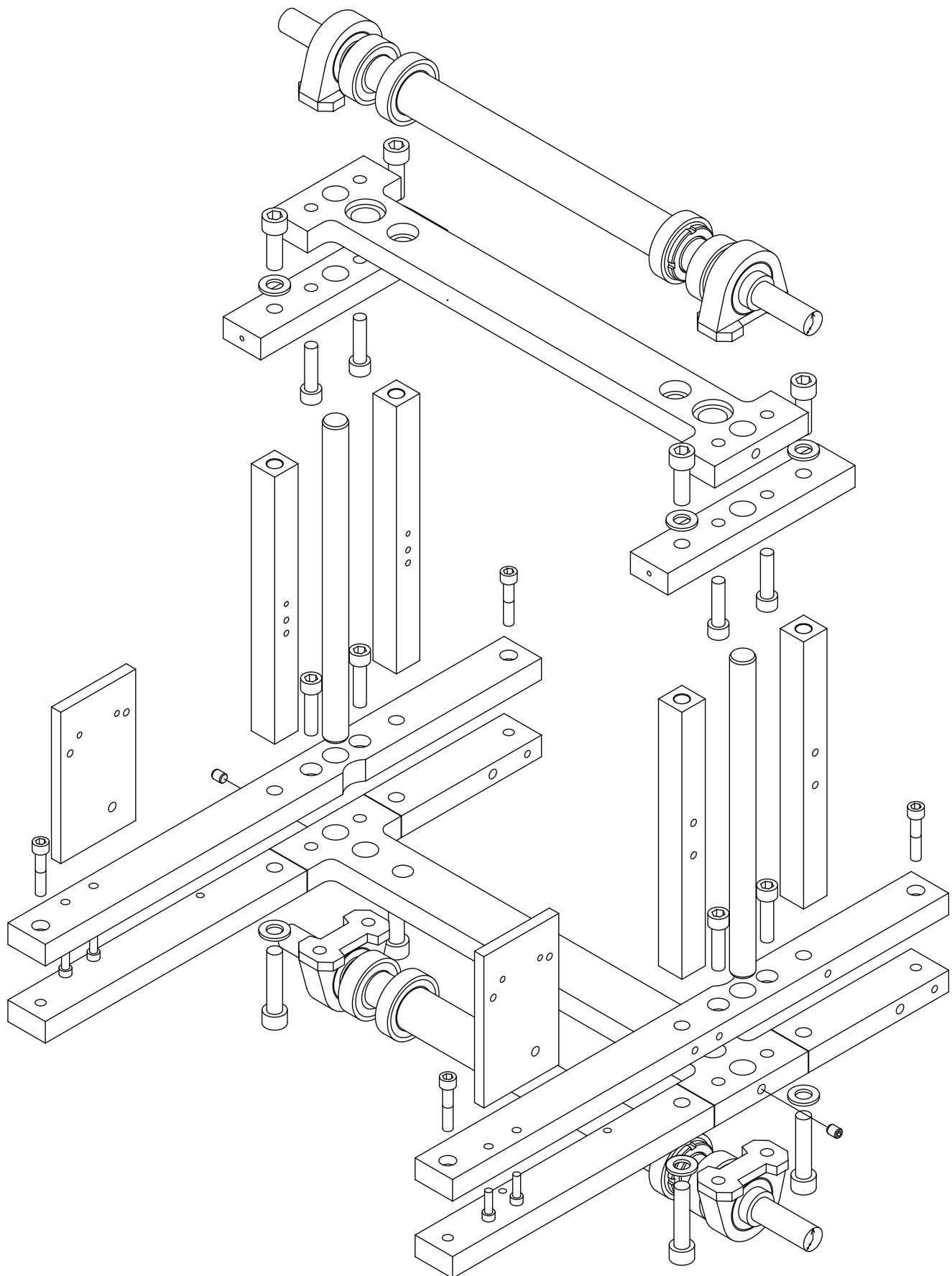

## Paper guides

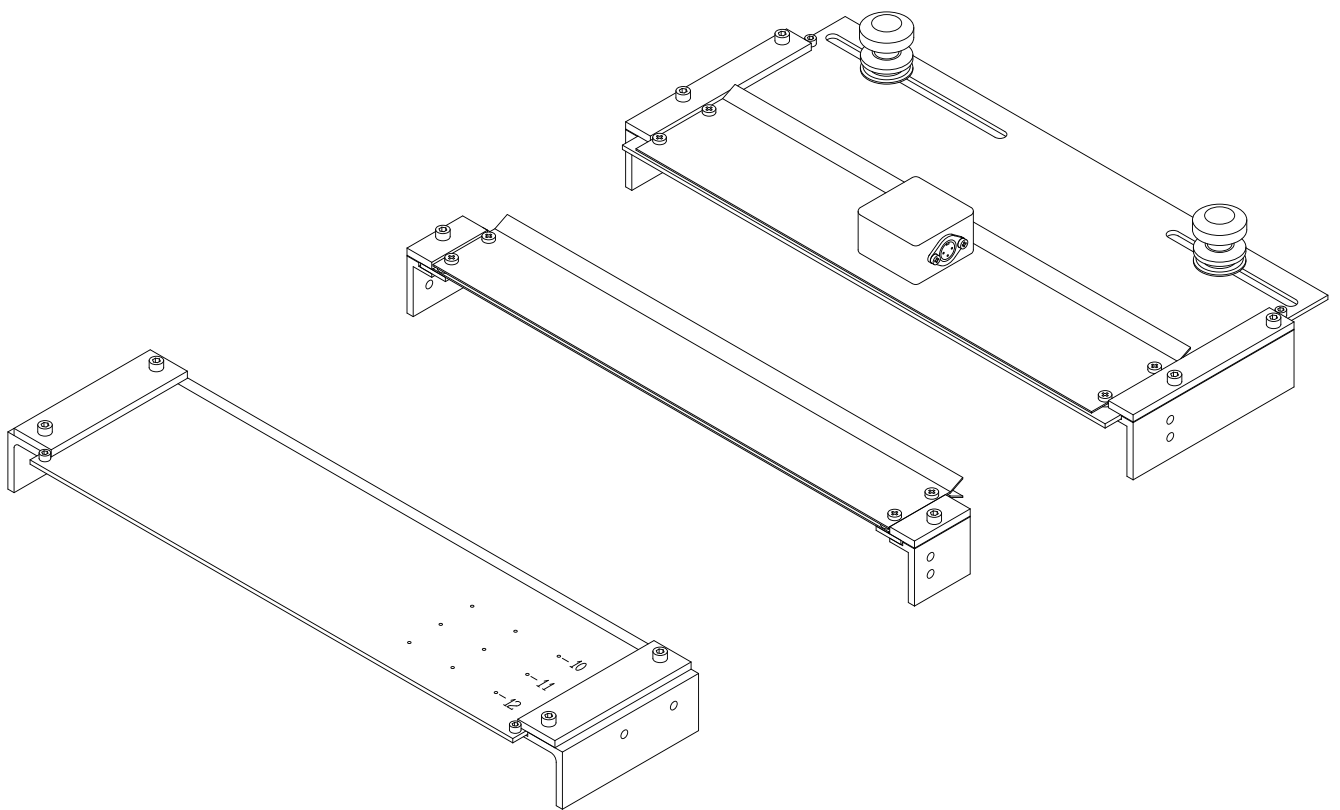

## 6. TECHNICAL SPECIFICATIONS

### 6.1 Technical specifications

#### Format:

Characters per line: 10-42 chars.  
 Sheet length: 4-14 inches  
 Sheet width: 140-330 mm  
 Page layout: Normal/Z-fold  
 Page 1: Up/down  
 Printing type: Single sided/interpoint  
 Line spacing: Adjustable, from 0.3175 mm to 10.16 mm. Standard is 5.08 mm  
 Dot: 6/8  
 Page length: No form feed/normal/normal-1 to -9 lines  
 Braille cell: Standard medium 6 or 8 dot.  
 Paper weight: 120 - 180 g/m<sup>2</sup>, recommended 150 g/m<sup>2</sup>

**Printing speed:** 400 characters per second, Approx. 1200 printed pages per hour.

#### Electrical:

Voltage: Single phase 220V (+/- 10 %), 50/60 Hz  
 Current: Approx. 5 A max  
 Fuse Printer: 10 A  
 Power: Approx. 1000 W max

#### Communication with the computer:

Parallel on Centronics (25 pin D-sub female), or  
 Serial on RS 232 C (25 pin D-sub male).  
 Both are electrical isolated with opto-couplers to prevent noise and ground loops.

#### Parameters for the serial port:

Baud rate: 150-19200  
 Parity: No/Odd/Even  
 Data bit: 7/8  
 Stop bit: 1/2

#### Environment:

Temperatures: 15-30 C (60-86 F)  
 Rel. Humidity: 40-60%

#### Measurements:

Height: 1250 mm  
 Width: 700 mm  
 Length: 1050 mm  
 Weight: 195 Kg

#### Patents:

Norway no. 140335  
 Great Britain no. 2040231  
 USA no. 4261663  
 Germany no. DE 2850780 C22

## 6.2 Electric unit, overview

The electric unit is placed on the baseplate of the printer, and contains connections, fuses and power supply. All fuses are 5 x 20 mm, and can be of glass or ceramic type.

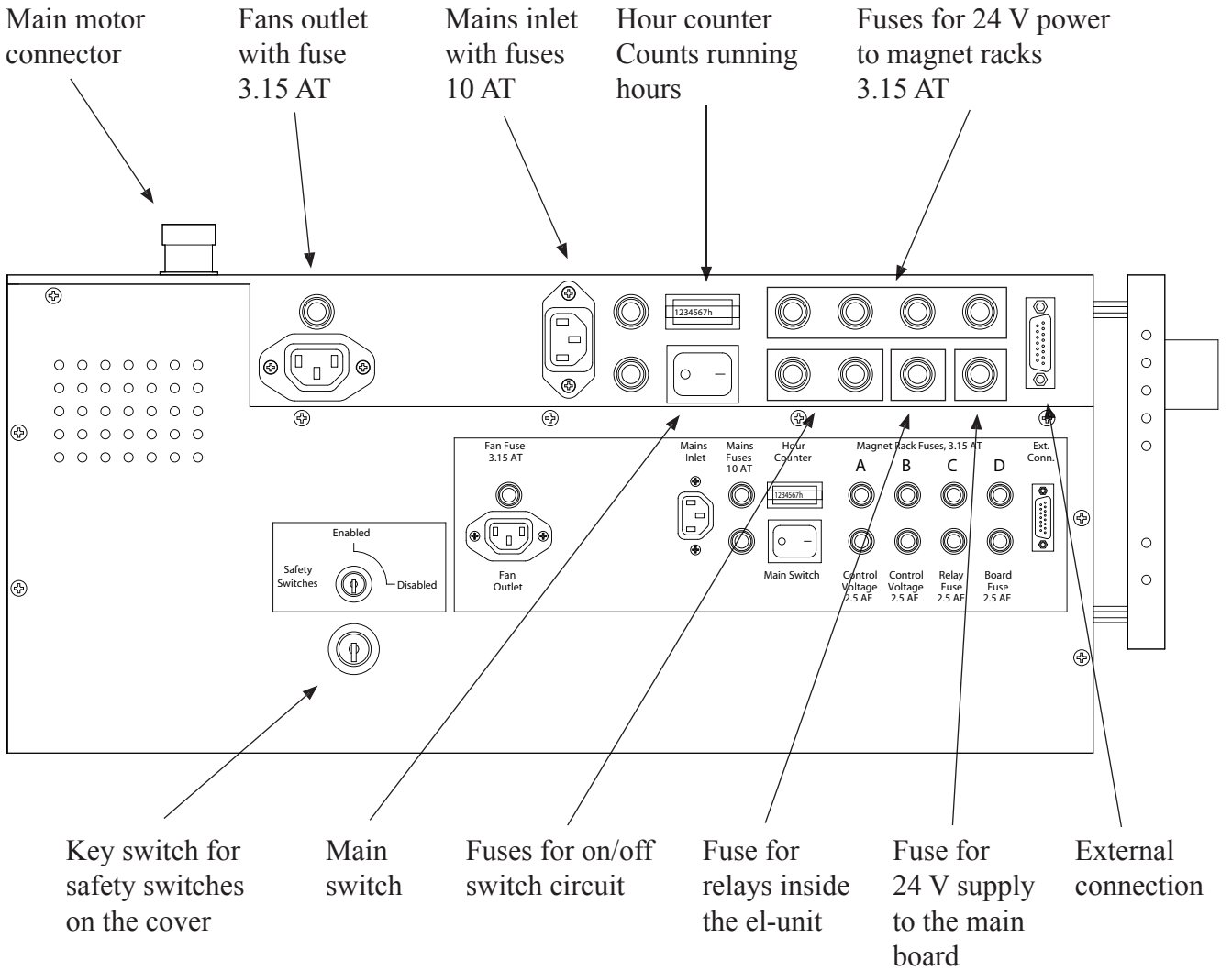

Electric unit, schematics

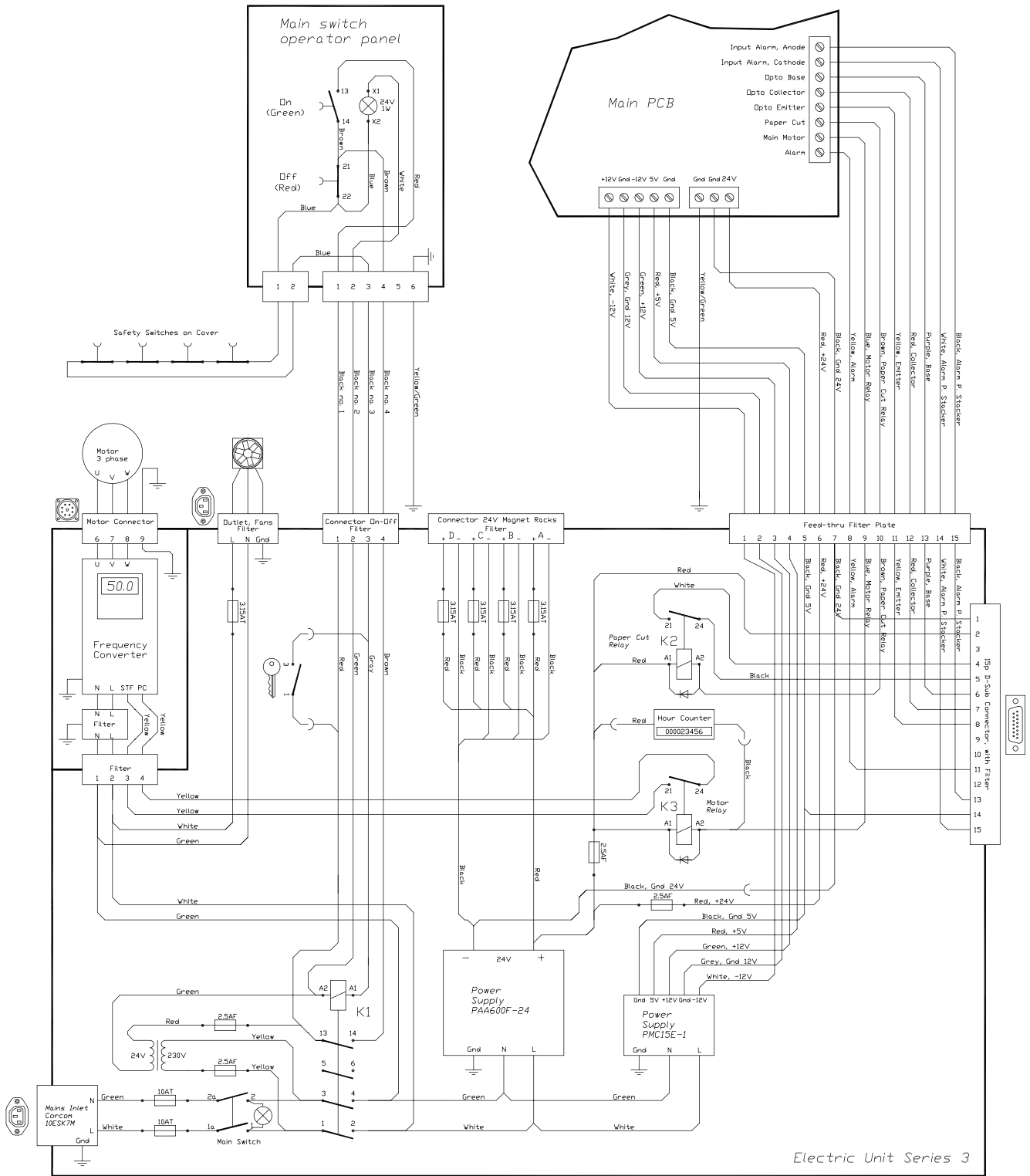

Electric Unit Series 3



### 6.3 Pin configuration external connection

There is a connector on the electric unit that can be used to connect the printer to other paper processing equipment.

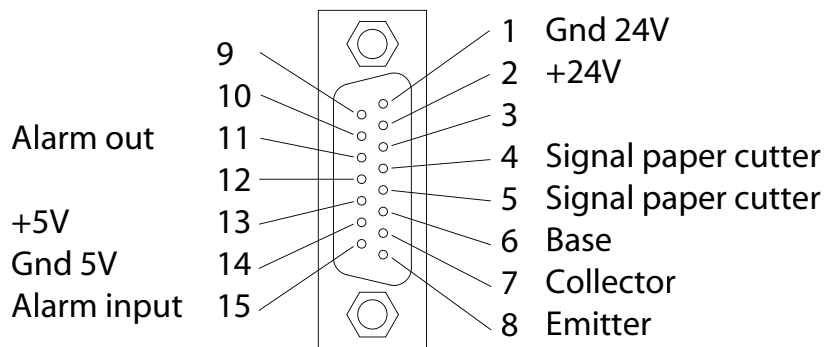
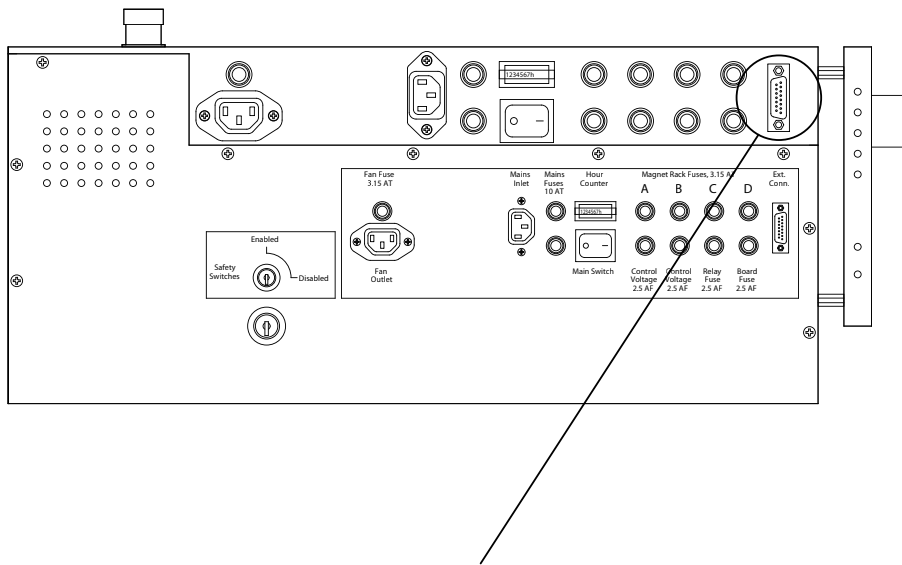

### 6.4 Main board, connections

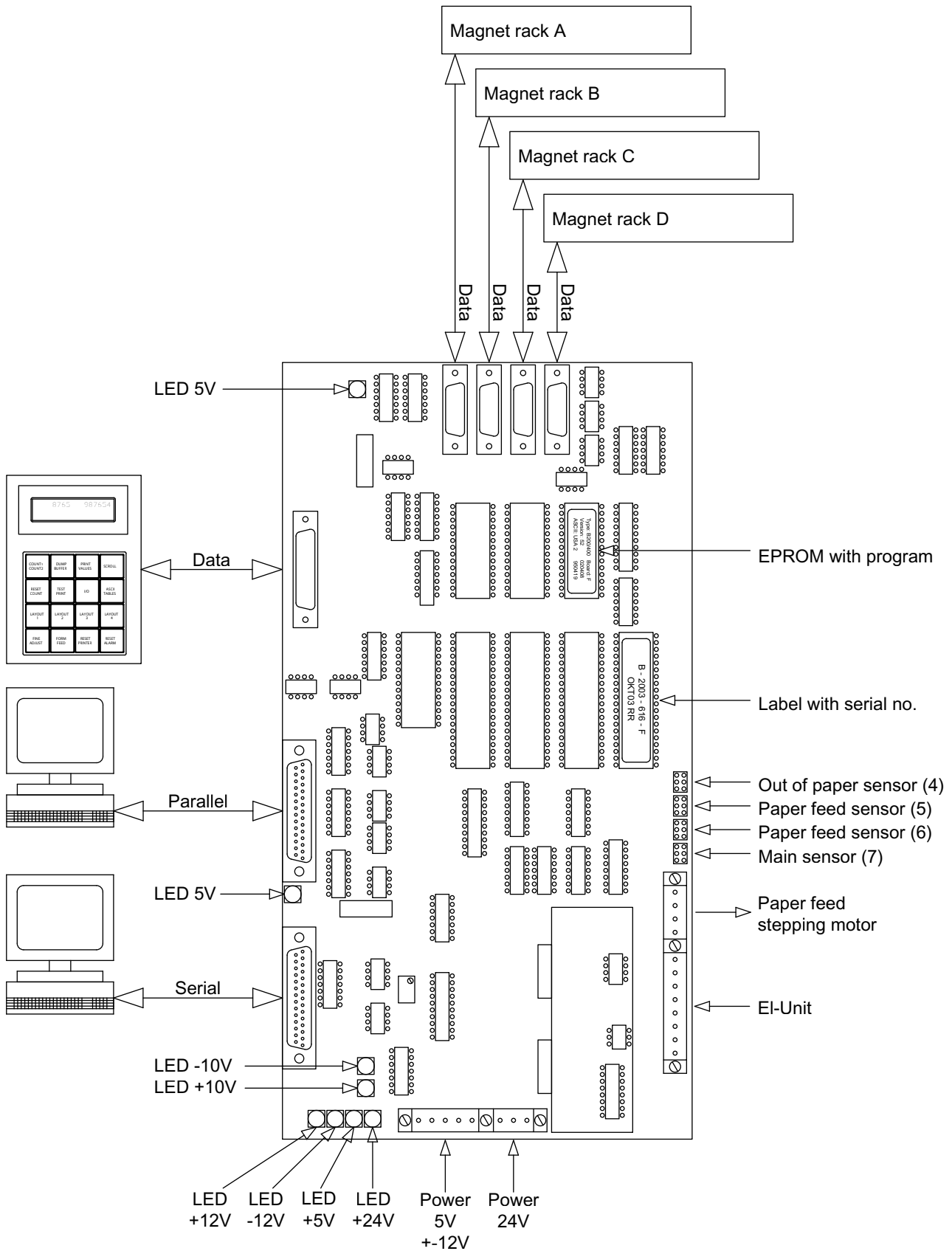

Main board, schematics

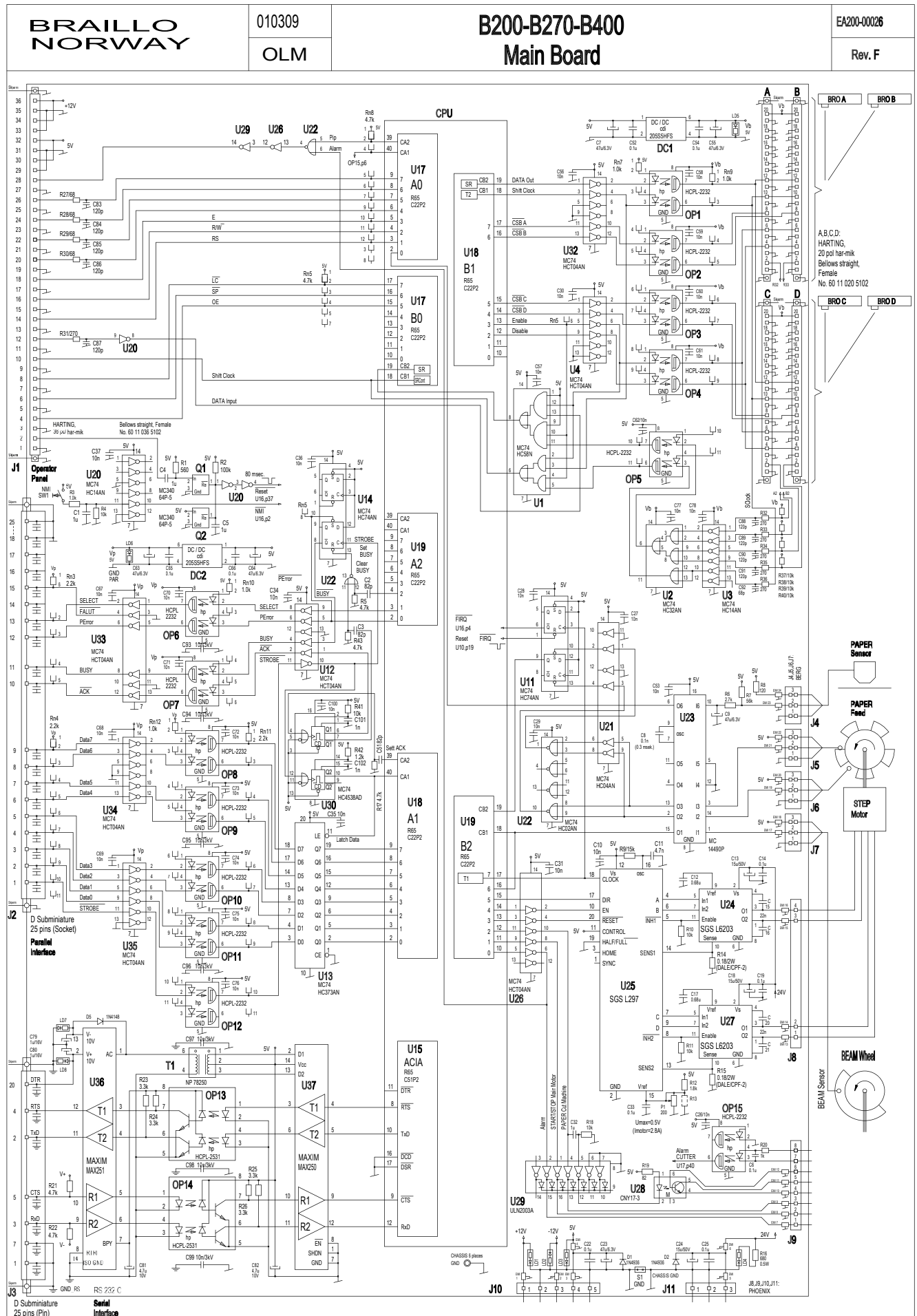

Main board, schematics CPU part

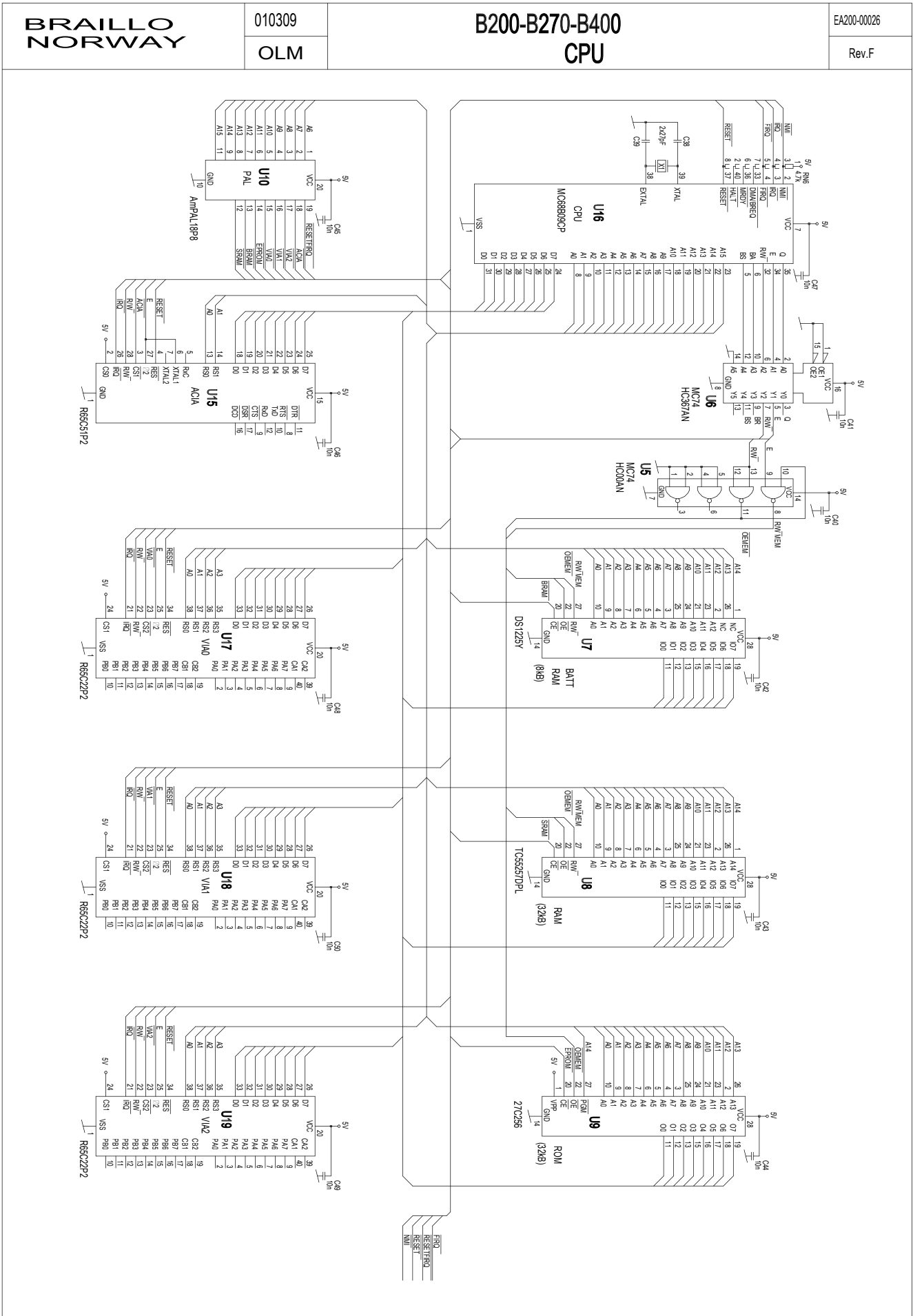

### 6.5 Magnet rack board, schematics

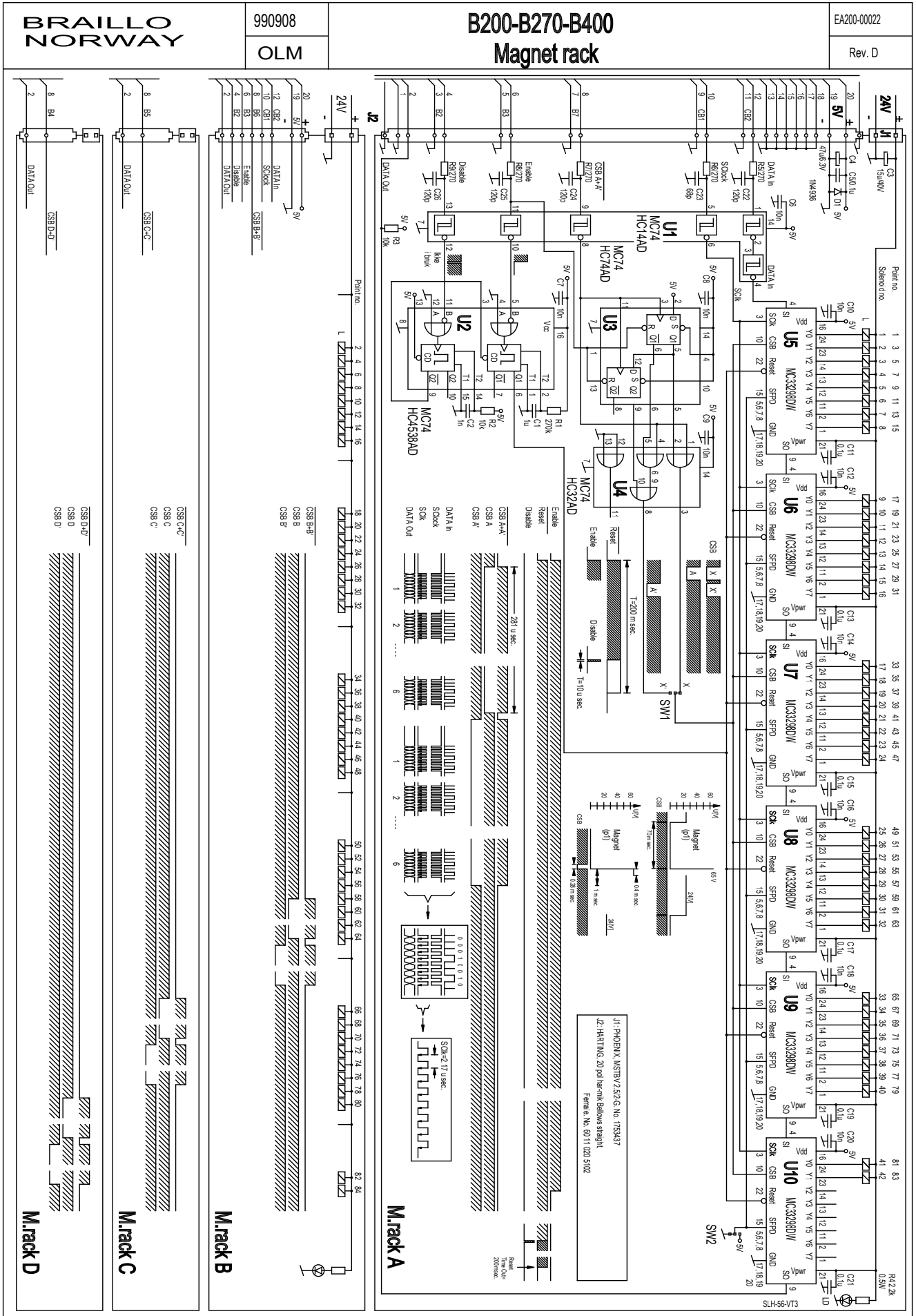

6.6 Operator panel, schematics

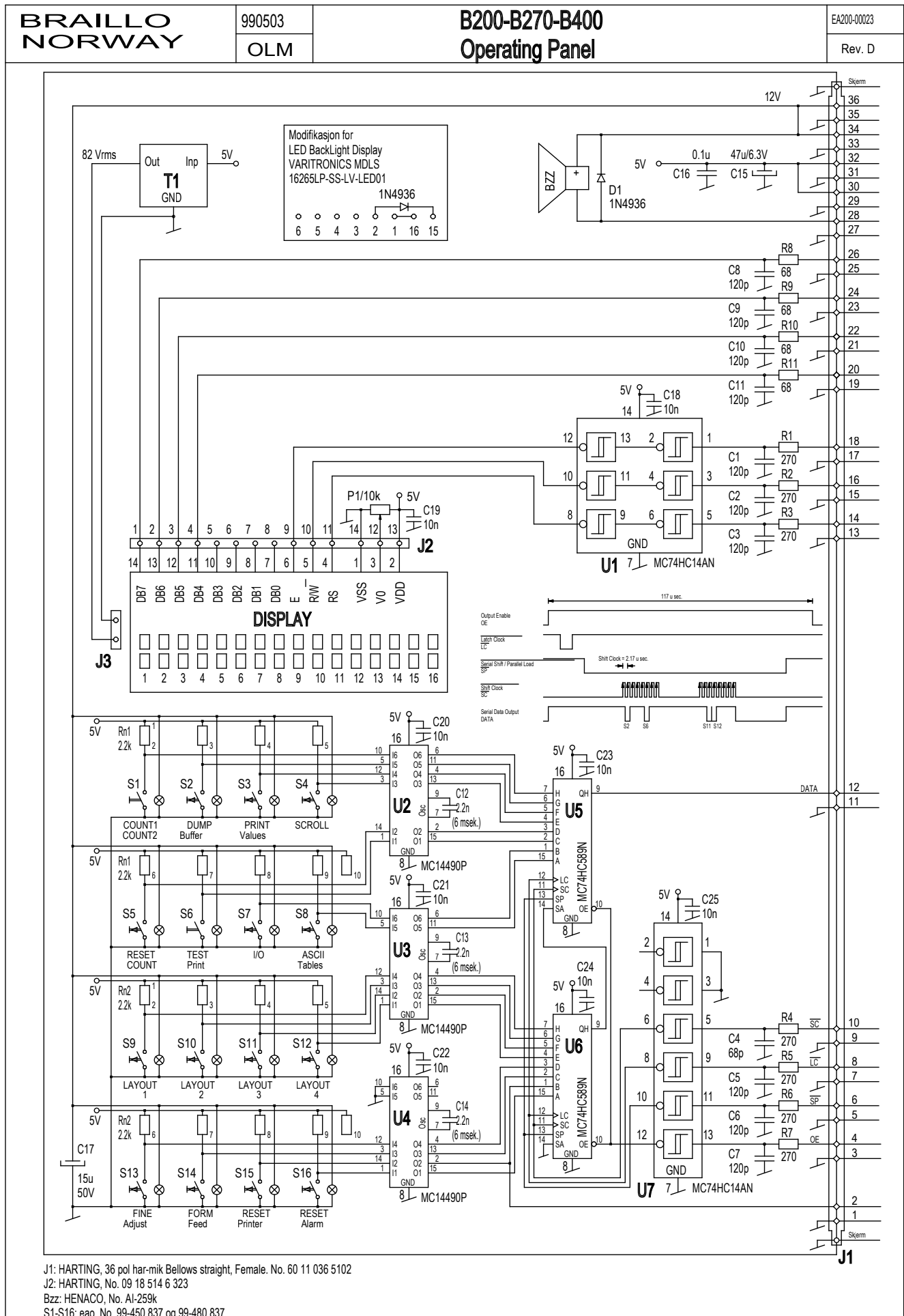

## 6.7 Pin configuration serial and parallel port

Data transmission from the computer to the printer can be done in two ways, either serial or parallel. The serial goes through an RS 232 C interface, and the parallel is using a Centronics compatible interface. Both connectors are of the 25 pin D-sub type.

### Pin configuration 25 pin male D-sub contact RS 232 C (serial port):

Pin no. 1	FG	Frame Ground	
Pin no. 2	Tx	Transmit data	Output
Pin no. 3	Rx	Receive data	Input
Pin no. 4	RTS	Request to send	Output
Pin no. 5	CTS	Clear to send	Input
Pin no. 6	DSR	Data set ready	Input
Pin no. 7	GND	Signal ground	
Pin no. 8	DCD	Data carrier detect	Input
Pin no. 9	PU	+ 12V (Logic high)	Output
Pin no. 20	DTR	Data terminal ready	Output

The printer is only using pin no. 4 (RTS) as a control signal. When this is set to logic low (from the printer), the computer must stop sending text immediately. Pin no. 2 (Tx) is used to transmit XON/XOFF control signals to the computer. The text sent to the printer is received through pin no. 3 (Rx). All other outputs from the printer are set to logic high.

### Wiring diagram for the enclosed serial cable

Standard RS 232 C cable, 25-25 pin:

25 pin female			25 pin female	
1	FG		FG	1
2	TD		RD	3
3	RD		TD	2
4	RTS	CTS, DSR		5,6
5,6	CTS, DSR		RTS	4
7	SG		SG	7
8	DCD		DTR	20
20	DTR		DCD	8

**Wiring diagram for the serial cable with 9 pins adaptor:**

Standard RS 232 C cable, 9-25 pin:

9 pin female		25 pin female	
1	DCD	DTR	20
2	RD	TD	2
3	TD	RD	3
4	DTR	DCD	8
5	SG	SG	7
6,8	CTS, DSR	RTS	4
7	RTS	CTS, DSR	5,6

**Pin configuration 25 pin female D-sub contact (parallel port):**

Pin no. 1	Strobe	Input	Active low
Pin no. 2	Data 0	Input	
Pin no. 3	Data 1	Input	
Pin no. 4	Data 2	Input	
Pin no. 5	Data 3	Input	
Pin no. 6	Data 4	Input	
Pin no. 7	Data 5	Input	
Pin no. 8	Data 6	Input	
Pin no. 9	Data 7	Input	
Pin no. 10	Acknowledge	Output	Active low
Pin no. 11	Busy	Output	
Pin no. 12	Paper out	Output	
Pin no. 13	Select	Output	
Pin no. 14	Not in use		
Pin no. 15	Error	Output	
Pin no. 16	Not in use		
Pin no. 17	Frame Ground		
Pin no. 18	Signal Ground		
Pin no. 19	Signal Ground		
Pin no. 20	Signal Ground		
Pin no. 21	Signal Ground		
Pin no. 22	Signal Ground		
Pin no. 23	Signal Ground		
Pin no. 24	Signal Ground		
Pin no. 25	Signal Ground		



## 6.8 Escape-sequences

What is an escape-sequence?

An escape-sequence is just a name for a code which is sent to the printer from the computer to change the parameters which control the way the printer works. All parameters that can be set via the operator panel, can also be changed with escape-sequences, (except those for the data communication, i.e. active port, baud rate, data bit, stop bit, and parity).

This makes it possible to have different codes (read; escape-sequences) stored in a document. So, when the document is sent to the printer, these codes are sent first and the printer sets itself in the correct mode and format automatically.



Note! When the printer receives an escape-sequence, it will have first priority. This means, regardless of the setting made before and regardless what the operator panel dictates, the most recent escape-sequence will take precedence.



Note! Escape-sequences should be placed at the very beginning of the first page on the sheet, (e.g page 1, 3, 5, 7 ...). However, a software form feed can be placed wherever needed. (If there is a command on the other pages, it will be skipped).

All page formatting which is done on the front page will also format the back of the same sheet. It is for example not possible to have 8 dot braille on the front page and 6 dot on the back page. It is possible to mix 6 and 8 dot braille however, as long as it is done on two different sheets.

An overview of the different escape-sequences:

ESC A nn	- Sheet length.	nn can be from 08 to 28 (4 to 14 inches).
ESC B nn	- Line length.	nn can be from 10 to 42 characters.
ESC C n	- Print format.	n can be 0 or 1, single-sided (0) or interpoint (1).
ESC H n	- Page layout.	n can be 0 or 1, normal (0) or Z-fold printing (1).
ESC I n	- Page 1 up/down.	n can be 0 or 1, up (0) or down (1).
ESC J n	- 6 / 8 dot braille.	n can be 0 or 1, 6 (0) or 8 (1) dot braille.
ESC M nn	- Line spacing.	nn can be from 0 to 16 step.
ESC N n	- Line single/double.	n can be 0 or 1, single (0) or double line spacing (1).
ESC R n	- Page adjust.	n can be from 0 to 9 lines.
ESC S n	- Form feed mode.	n can be 0 or 1, no form feed (0) or normal form feed (1).
ESC T nn	- Page margin.	nn can be from 0 to 20 step.
ESC 0	- Soft reset	
ESC 1	- Soft form feed	
ESC 3	- ASCII-table from PC	



Note! The escape-sequences will be executed immediately if the printer is not running. However, if the printer is running, the escape-sequences will keep their place in the document, and will be executed when this particular page is printed. Also keep in mind that any page formatting command must be kept on the front page of a sheet. Then the command will affect both the front and back page, i.e. one sheet. If there are page formatting commands on the back page of a sheet, these comands will be skipped.

Please see the following explanations on how to combine different values to get the different escape-sequences.

**Sheet length:**

ESC A nn - Sheet length. nn can be from 4 to 14 inches.

**Line length:**

ESC B nn - Line length. nn can be from 10 to 42 characters.

nn can be a number from 8 to 28, corresponding to the length of the sheet in inches times two. (A 12 inch sheet will have the number 24).

Inches	ASCII	HEX
04.0	027 065 048 056	1B 41 30 38
04.5	027 065 048 057	1B 41 30 39
05.0	027 065 049 048	1B 41 31 30
05.5	027 065 049 049	1B 41 31 31
06.0	027 065 049 050	1B 41 31 32
06.5	027 065 049 051	1B 41 31 33
07.0	027 065 049 052	1B 41 31 34
07.5	027 065 049 053	1B 41 31 35
08.0	027 065 049 054	1B 41 31 36
08.5	027 065 049 055	1B 41 31 37
09.0	027 065 049 056	1B 41 31 38
09.5	027 065 049 057	1B 41 31 39
10.0	027 065 050 048	1B 41 32 30
10.5	027 065 050 049	1B 41 32 31
11.0	027 065 050 050	1B 41 32 32
11.5	027 065 050 051	1B 41 32 33
12.0	027 065 050 052	1B 41 32 34
12.5	027 065 050 053	1B 41 32 35
13.0	027 065 050 054	1B 41 32 36
13.5	027 065 050 055	1B 41 32 37
14.0	027 065 050 056	1B 41 32 38

Default is 12 inches.

Char	ASCII	HEX
10	027 066 049 048	1B 42 31 30
11	027 066 049 049	1B 42 31 31
12	027 066 049 050	1B 42 31 32
13	027 066 049 051	1B 42 31 33
14	027 066 049 052	1B 42 31 34
15	027 066 049 053	1B 42 31 35
16	027 066 049 054	1B 42 31 36
17	027 066 049 055	1B 42 31 37
18	027 066 049 056	1B 42 31 38
19	027 066 049 057	1B 42 31 39
20	027 066 050 048	1B 42 32 30
21	027 066 050 049	1B 42 32 31
22	027 066 050 050	1B 42 32 32
23	027 066 050 051	1B 42 32 33
24	027 066 050 052	1B 42 32 34
25	027 066 050 053	1B 42 32 35
26	027 066 050 054	1B 42 32 36
27	027 066 050 055	1B 42 32 37
28	027 066 050 056	1B 42 32 38
29	027 066 050 057	1B 42 32 39
30	027 066 051 048	1B 42 33 30
31	027 066 051 049	1B 42 33 31
32	027 066 051 050	1B 42 33 32
33	027 066 051 051	1B 42 33 33
34	027 066 051 052	1B 42 33 34
35	027 066 051 053	1B 42 33 35
36	027 066 051 054	1B 42 33 36
37	027 066 051 055	1B 42 33 37
38	027 066 051 056	1B 42 33 38
39	027 066 051 057	1B 42 33 39
40	027 066 052 048	1B 42 34 30
41	027 066 052 049	1B 42 34 31
42	027 066 052 050	1B 42 34 32

Default is 42 characters pr. line.

**Print Format:**

ESC C n - Print Format.  
n can be 0 (single-sided) or 1 (interpoint).

Print Format	ASCII	HEX
Single-sided	027 067 048	1B 43 30
Double-sided	027 067 049	1B 43 31

Default is Double-sided.

**Page layout:**

ESC H n - Page Layout.  
n can be 0 (normal) or 1 (Z-fold printing).

Page Layout	ASCII	HEX
Normal	027 072 048	1B 48 30
Z-fold	027 072 049	1B 48 31

Default is Normal Page Layout.

**Page 1 up or down:**

ESC I n - Page 1 up/down.  
n can be 0 (up) or 1 (down).

Page 1	ASCII	HEX
Up	027 073 048	1B 49 30
Down	027 073 049	1B 49 31

Default is Page 1 Up.

**6 / 8 dot braille:**

ESC J n - 6 / 8 dot braille.  
n can be 0 (6) or 1 (8 dot braille).

Braille	ASCII	HEX
6 dot	027 074 048	1B 4A 30
8 dot	027 074 049	1B 4A 31

Default is 6 dot braille.

**Line spacing:**

ESC M nn - Line Spacing.  
nn can be from 0 to 16 step.

Step	mm	ASCII	HEX
0	0.0000	027 077 048 048	1B 4D 30 30
1	0.3175	027 077 048 049	1B 4D 30 31
2	0.6350	027 077 048 050	1B 4D 30 32
3	0.9525	027 077 048 051	1B 4D 30 33
4	1.2700	027 077 048 052	1B 4D 30 34
5	1.5875	027 077 048 053	1B 4D 30 35
6	1.9050	027 077 048 054	1B 4D 30 36
7	2.2225	027 077 048 055	1B 4D 30 37
8	2.5400	027 077 048 056	1B 4D 30 38
9	2.8575	027 077 048 057	1B 4D 30 39
10	3.1750	027 077 049 048	1B 4D 31 30
11	3.4925	027 077 049 049	1B 4D 31 31
12	3.8100	027 077 049 050	1B 4D 31 32
13	4.1275	027 077 049 051	1B 4D 31 33
14	4.4450	027 077 049 052	1B 4D 31 34
15	4.7625	027 077 049 053	1B 4D 31 35
16	5.0800	027 077 049 054	1B 4D 31 36

16 steps are the standard line spacing (5.08 mm or 0.2”), 8 is the setting for making dots continuously down the sheet. (linespacing is 2.54 mm or 0.1”). Note that if the setting is less than 7, and there is text on each line, the dots might get damaged in the printing process.

Default is 16 steps.

**Single / Double Line Spacing:**

ESC N n - Line Single/Double.  
n can be 0 (single) or 1 (double) line spacing

Line Spacing	ASCII	HEX
Single	027 078 048	1B 4E 30
Double	027 078 049	1B 4E 31

The function “Single or Double line spacing” will double the given line spacing. If, e.g. the current line spacing is 13 steps (4.1275 mm), selecting Double line spacing will increase it to 26 steps (8.2550 mm).

Default is Single Line Spacing.

**Page Adjust:**

ESC R n - Page adjust.  
n can be from 0 to 9 lines.

Please keep in mind that there is a difference in the terms “page length” and “sheet length”. By page length we mean the number of lines of text to be printed on a page, and by sheet length we mean the physical size of a sheet of paper in inches.

The number of lines which can be printed on a page, is dependent on whether 6 or 8 dot braille is used, whether what kind of line spacing is in use, and whether page length is set for Maximum, Maximum-1 or upto -9.

Omitted

Lines	ASCII	HEX
0	027 082 048	1B 52 30
1	027 082 049	1B 52 31
2	027 082 050	1B 52 32
3	027 082 051	1B 52 33
4	027 082 052	1B 52 34
5	027 082 053	1B 52 35
6	027 082 054	1B 52 36
7	027 082 055	1B 52 37
8	027 082 056	1B 52 38
9	027 082 057	1B 52 39

This setting will decrease the number of lines on each page from 1 to 9, (depending on the selected number). If the maximum number of lines could be 29, and the setting “Max-4” is selected, the resulting number of lines will be 25. On interpoint, this function will centre the text vertically on the page and keep the top and bottom margin approx. equal. On singlesided, it will keep the top margin constant and only the bottom margin will vary.

Default is Maximum number of lines per page.

**Form Feed Mode:**

ESC S n - Form Feed Mode.  
n can be 0 (no form feed) or 1 (normal form feed)

Form Feed Mode	ASCII	HEX
No Form Feed	027 083 048	1B 53 30
Normal Form Feed	027 083 049	1B 53 31

Default is Normal Form Feed.

**Page Margin:**

ESC T nn - Page margin.  
nn can be from 0 to 20 step.

Step	mm	ASCII	HEX
0	0.0000	027 084 048 048	1B 54 30 30
1	0.6350	027 084 048 049	1B 54 30 31
2	1.2700	027 084 048 050	1B 54 30 32
3	1.9050	027 084 048 051	1B 54 30 33
4	2.5400	027 084 048 052	1B 54 30 34
5	3.1750	027 084 048 053	1B 54 30 35
6	3.8100	027 084 048 054	1B 54 30 36
7	4.4450	027 084 048 055	1B 54 30 37
8	5.0800	027 084 048 056	1B 54 30 38
9	5.7150	027 084 048 057	1B 54 30 39
10	6.3500	027 084 049 048	1B 54 31 30
11	6.9850	027 084 049 049	1B 54 31 31
12	7.6200	027 084 049 050	1B 54 31 32
13	8.2550	027 084 049 051	1B 54 31 33
14	8.8900	027 084 049 052	1B 54 31 34
15	9.5250	027 084 049 053	1B 54 31 35
16	10.1600	027 084 049 054	1B 54 31 36
17	10.7950	027 084 049 055	1B 54 31 37
18	11.4300	027 084 049 056	1B 54 31 38
19	12.0650	027 084 049 057	1B 54 31 39
20	12.7000	027 084 050 048	1B 54 32 30

The “Page Margin” function will adjust the page margin in steps from 0 to 20. The standard setting is 8, (8 = normal). The page margin will give different effect when used on single-sided, compared with double-sided. On double-sided printing, one step is equal to 0.6350 mm, and the text will be centred vertically on the page. If, e.g. a page margin on 6 steps is selected, the printer will print closer to the edges of the paper, and if a page margin on 20 steps is selected, it will give a larger page margin. This will affect both top and bottom margins, i.e. page margin. On single-sided printing, however, the page margin will actually work as a top margin. (Note! The page layout must be set to normal). One step is equal to 0.6350 mm. It will “push” the text downwards the sheet. If the text reaches the bottom, (meaning that there will not be enough space on this page for the last line), this line will wrap over to the next page.

Default is 8 steps.

**Software Reset:**

ESC 0 - Soft Reset

This command is used to reset the Printer. It is used from the computer and has the same effect as pushing the key RESET PRINTER. Software Reset should be used with care: If the printer has not finished printing, the rest of the text in the buffer will be lost, and a new paper position will be assumed by the Printer. Because of this, the command is only to be used after a software form feed has been executed, and the Printer has stopped completely.

	ASCII	HEX
Software Reset	027 048	1B 30

**Software Form Feed:**

ESC 1 - Soft Form Feed

This command is to be used after all text in one volume has been transmitted to the Printer. If text corresponding to less than two pages, or text with an odd number of pages is received, and not followed by FF on the last page, the Printer will wait for more text or FF. This means that the last page may be stuck in the Printer. This is due to the double-sided printing of the Printer. This command makes the Printer to start printing the rest of the text. After this the paper position will be the same as it had when this volume of text was started. Then page no. 1 on the next volume will start out correctly. There will always be at least one blank sheet of paper between the volumes of text when finishing each volume with a Software Form Feed.

	ASCII	HEX
Software Form Feed	027 049	1B 31

## 7. GENERAL INFORMATION

### 7.1 Declaration of conformity

Manufacturer :

**Braillo Norway as**  
**PO.box 93 N-7501**  
**Norway**

The manufacturer hereby declares that **Braillo 400 serie III** from serial no: **B4-001** produced year **1999**:

is designed and produced in accordance with the in accordance with the requirement of the Council Directive of 14th June 1989, on the approximation of the laws of the Member States relating to machinery as implemented in Norway by Arbeidstilsynets Bekjentgjørelse nr.694 of 7th August 1992 and conforms to the essential health and safety requirements as referred to in Article 3.

The following Standards were applied:

89/392/EØF  
 91/368/EØF  
 93/68/EØF

The manufacturer further declares that the machine is designed and produced in accordance with the Council Directive of 19th. February 1973 (73/23/EEC) on the approximation of the laws of the Member States relating to equipment used within certain voltage limits (The low Voltage Directive). The CE marking is applied from year 1999.

The following Standards were applied:

73/23/EØF

The manufacturer declares that the machine is designed for use in Office Environment and Light Industry and that it is designed and produced to comply with the Council Directive of 3rd.May 1989 (89/336/EEC) on the approximation of the laws of the member States relating to Electromagnetic Compatability.

The following Harmonized Standards has been applied:

EN50081-1 1992  
 EN55022B  
 EN50082-1 1992  
 IEC-801-4 1989

Signed: Stjørdal, 2 January 1999 on behalf of Braillo Norway AS

Managing director  
 Title

Kjell Egil Sæves  
 Name

  
 Signature

## 7.2 Warranty

This product left the factory in a good working condition in accordance with the technical specifications and carries a warranty of 2 years on parts valid from the date of delivery from Braillo Norway A/S.

### **The warranty includes:**

- Replacement of defect part(s)
- Shipping cost for the replaced part(s)

### **The warranty excludes:**

- On-site part replacement (labor, travelling and living expenses for a service engineer)
- Shipping costs for sending the faulty unit back to Braillo Norway A/S (see below).
- Altered product (except as authorized by Braillo Norway A/S) or product not installed or maintained in accordance with Braillo Norway's instructions.
- Customs and duties
- Incidents involving Force Major (for example flooding, earth quake etc. damaging the product).

### **Should a replacement part be required, please do the following:**

Send us a "Warranty request form". Please refer to the next page to see the actual form. The form can also be found on the enclosed CD-ROM. After completing the form, please return it to Braillo Norway A/S by e-mail, fax or regular mail. When received, the parts will be shipped as soon as possible.

### **What to do with the defective part(s):**

If a communication has been made to our service department, and an approval has been given, it will not be necessary to return the part(s) to Braillo Norway A/S. In all other cases, the part(s) must be returned to Braillo Norway A/S as soon as possible. If the part(s) has/have not been received by Braillo Norway A/S within 2 months from the date of issuing the "Warranty request form", this is no longer regarded as a warranty matter and an invoice will be issued and sent.

## Warranty request form

(Only one printer/part per document)

Customer name:		Date:
Contact person:		
Phone number:	Fax number:	E-mail address:
Printer type:		Printer number:
Part name:		Part number:

Reason for return:
--------------------

Comments:
-----------

Return to: Braillo Norway A/S Wesselveg 1 7500 Stjørdal Norway	Phone number: +47 74 84 04 40 Fax number: +47 74 84 04 41 E-mail: <a href="mailto:service@braillo.no">service@braillo.no</a>
--	--

If this document is not returned within two weeks of origination  
 We will assume that it is not required and it will be cancelled.

Internal use only:	
Garanti?	
Kunde belastes	
Kommentarer på reparasjon	



### 7.3 Adresses and phone numbers

#### Administration/Sales department Braillo Norway AS:

Office: Storgt. 31, Tønsberg  
Mail: P.O.Box 447  
3101 Tønsberg  
Norway  
Phone: +47 33 00 28 70  
Telefax: +47 33 00 28 71  
e-mail: [braillo@braillo.no](mailto:braillo@braillo.no)

#### Service Braillo Norway AS:

Office: Wesselsvei 1, Stjørdal  
Mail: P.O.Box 93  
7501 Stjørdal  
Norway  
Phone: +47 74 84 04 40  
Telefax: +47 74 84 04 41  
e-mail: [service@braillo.no](mailto:service@braillo.no)